

AKCP

Est USA 1981

2024 PRODUCT CATALOG



www.akcp.com

sales@akcp.com

About AKCP

AKCP established in the USA in 1981 created the market for temperature, environmental and power monitoring in the data center. Today with over 150 employees and 200,000 installations, AKCP is the world's oldest and largest manufacturer of networked wired and wireless sensor solutions.

Deploying the AKCP monitoring solution creates a Digital Twin of your data center. A virtual copy of the physical data center used to simulate scenarios, predict performance and improve efficiency and reliability.

AKCP designs, manufactures and tests everything in house with our SMT production line, clean room and packaging equipment. Every unit gets a 2 day burn in before shipping

Setting the standards for technical achievement and innovation including sensorCFD™, Wireless Tunnel™ and Digital Twins. Our outstanding level of support to all customers large and small, defines AKCP's success.

Our customers are diverse and include fortune 500 companies, government agencies, banks and military. Below are just some of our 200,000 installations worldwide.



Network Enabled Base Unit

All base units have an embedded web interface which can be accessed via the units IP address. Devices can also be monitored with AKCPro Server.

Ethernet

Ethernet connection on every base unit. Access sensor data over the base units own embedded web interface. IPV4 and IPV6 are supported

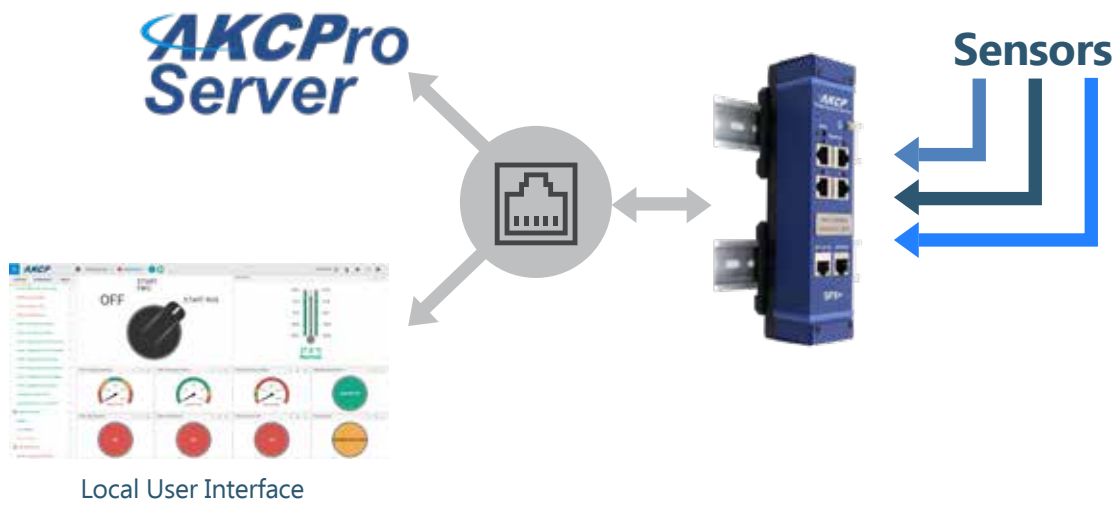

Cellular

Cellular 4G modems for communications at remote sites. GPS option for location tracking of sensors.

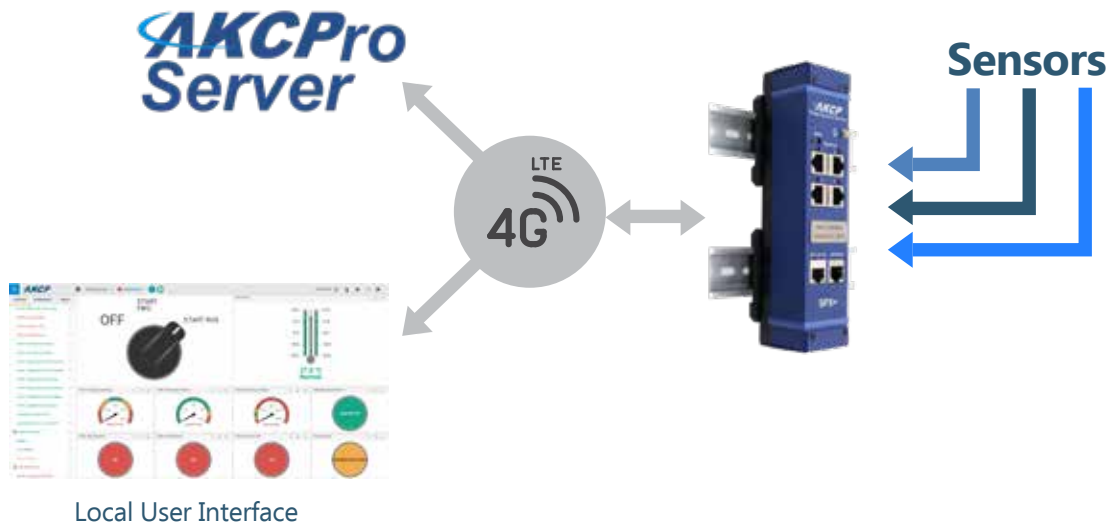

Communication Protocols

AKCP supports multiple communication protocols to interface with a range of industrial third party equipment. Used in building, factory and process automation, we can monitor your existing equipment.

SNMP

All data can be obtained over SNMP. Compatible with industry standard software. Complete MIB is supplied. SNMPV1 - 3 are supported

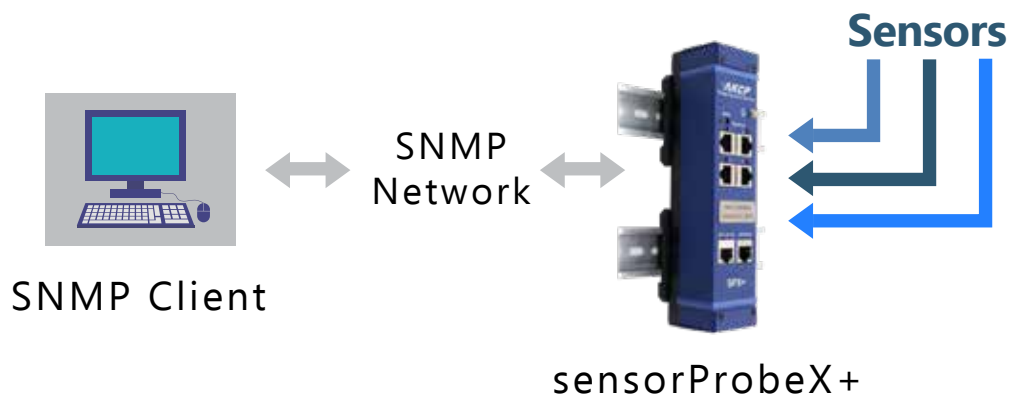

ModBus

Base units equipped with a Modbus RS485 port allow use as a Modbus to SNMP gateway. Base units can function as Modbus Master or Slave, and support Modbus RS485 or Modbus TCP/IP.

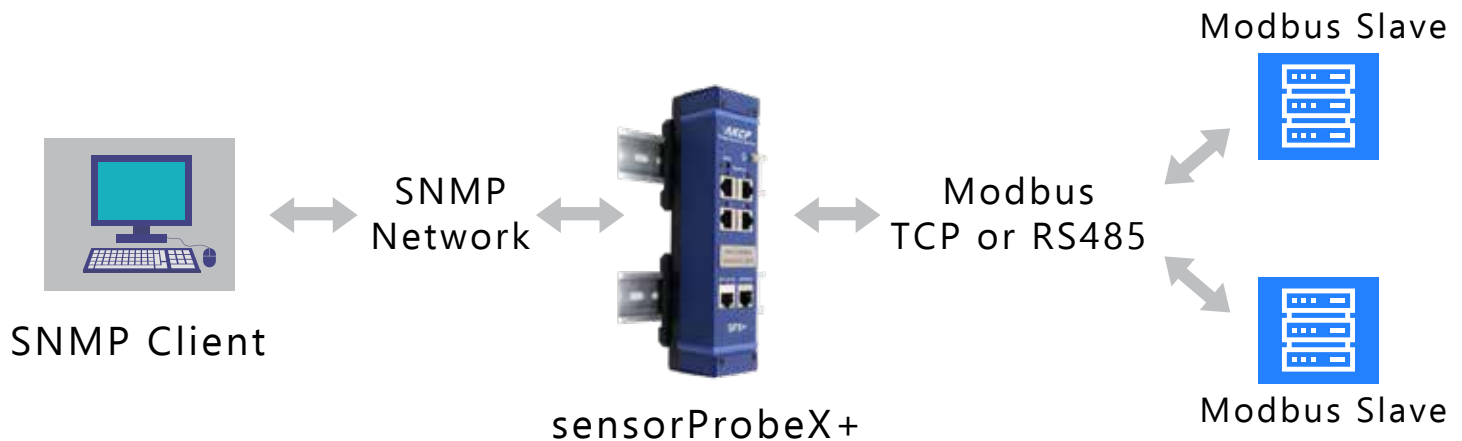

Wireless Tunnel™ Technology

AKCP Wireless Tunnel™ technology is an end to end wireless system with sensors, gateways and central monitoring platform.

Wireless Tunnel™

Wireless Tunnel™ technology provides long range, high penetration, low power, wireless sensor communication. AKCP developed the LoRaWAN™ protocol for firmware updates over the air, queuing and acknowledgment of sensor data and immediate broadcast on threshold violation (when not under battery operation). We have the most professional low power wireless system on the market.

Wireless Tunnel™ technology provides long range, low power, wireless sensor communication. AKCP layered the Wireless Tunnel™ protocol on Semtechs LoRa™ chirp spectrum radio

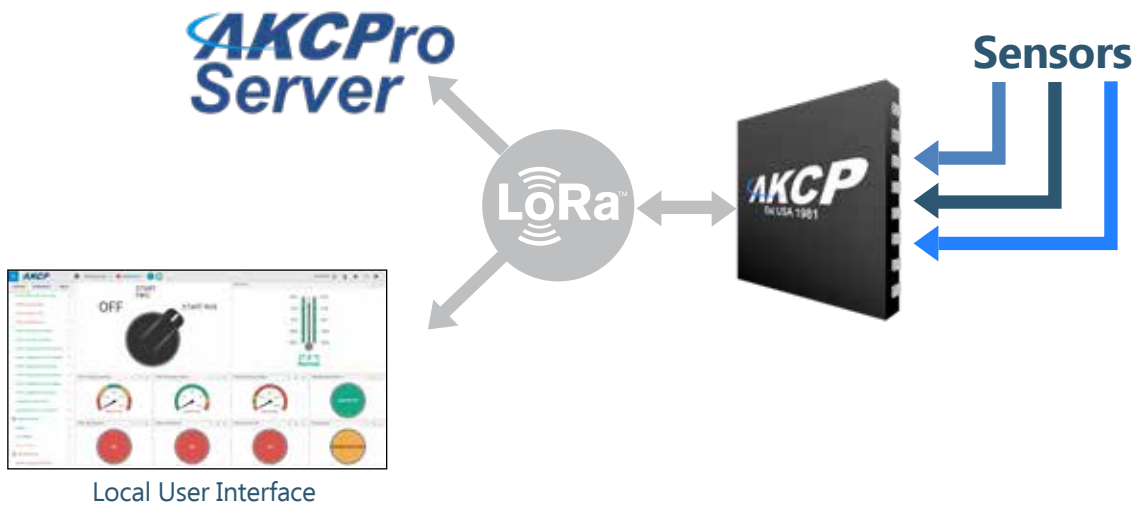

Directory

1. AKCP Product Solutions
 - 1.1 Data Center
 - 1.2 Warehouses and Cold Storage
 - 1.3 Medical and Pharmaceuticals
 - 1.4 HVAC
 - 1.5 Solar and Battery Power
 - 1.6 Generator and Fuel

2. Base Units
 - 2.1 sensorProbe+
 - 2.2 securityProbe
 - 2.3 Expansion Units
 - 2.4 Access Control
 - 2.5 Wireless Tunnel™

3. Software
 - 3.1 AKCPro Server
 - 3.2 AKCP Cloud Service
 - 3.3 sensorCFD™

4. Intelligent Sensors
 - 4.1 Environmental Sensors
 - 4.2 Security Sensors
 - 4.3 Power Sensors
 - 4.4 Specialty Sensors

5. Accessories
 - 5.1 Rack and DIN
 - 5.2 Power Supplies

6. Power Supplies
 - 6.1 DC to DC Power Converters

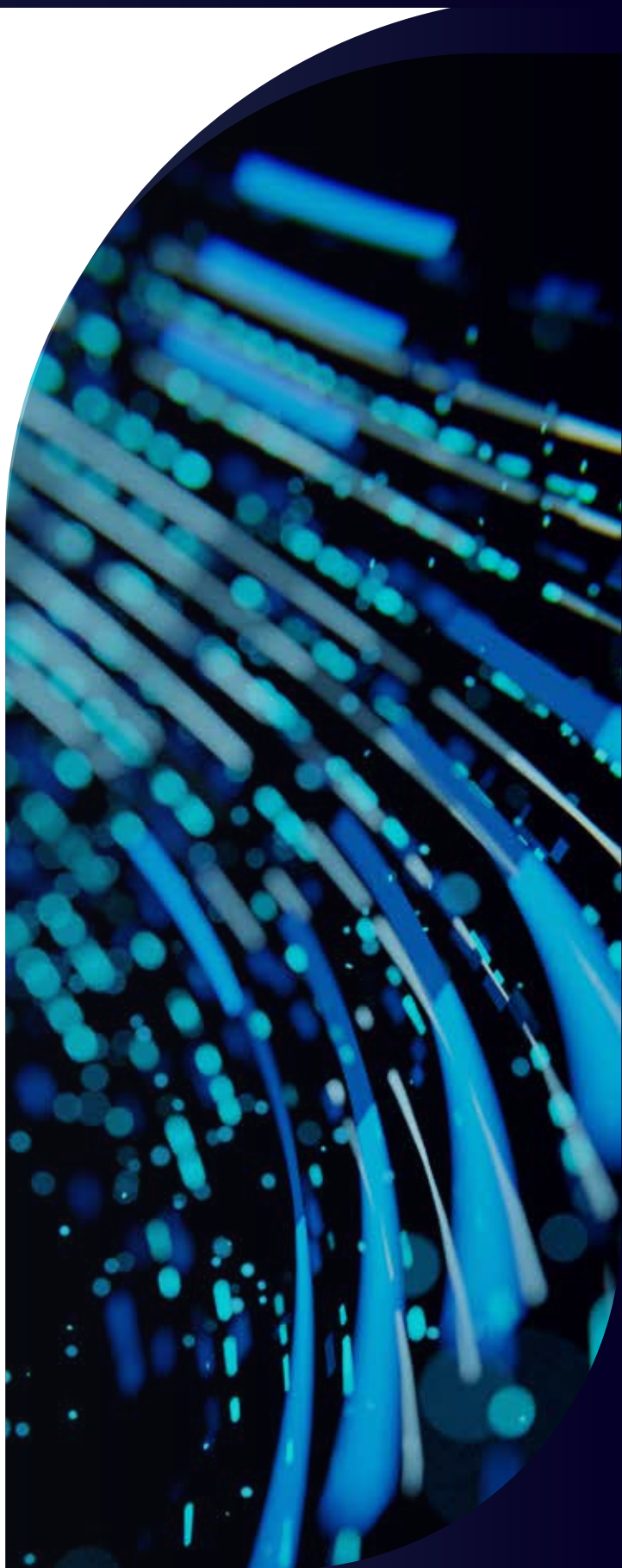

DATA CENTER MONITORING

AKCP has been the worlds leading supplier of data center monitoring solutions for over 30 years. Our wired or wireless sensor technology monitors environmental conditions, security and power in your data center.

- Control access to individual cabinets with RFID Swing Handle Locks
- Secure doors and containment aisles with RFID access control
- Monitoring of temperature and humidity, Thermal Mapping of Racks.
- Water leak detection protects IT infrastructure from disaster
- Monitoring complete power train with live PUE calculations
- Integration to third-party equipment via SNMP or Modbus virtual sensors
- HVAC control and monitoring of pipe pressures and temperatures
- Synchronize sensor events with IP video cameras

Rapid deployment of the Wireless Tunnel™ sensor system with AKCPro Server DCIM and battery powered sensors.

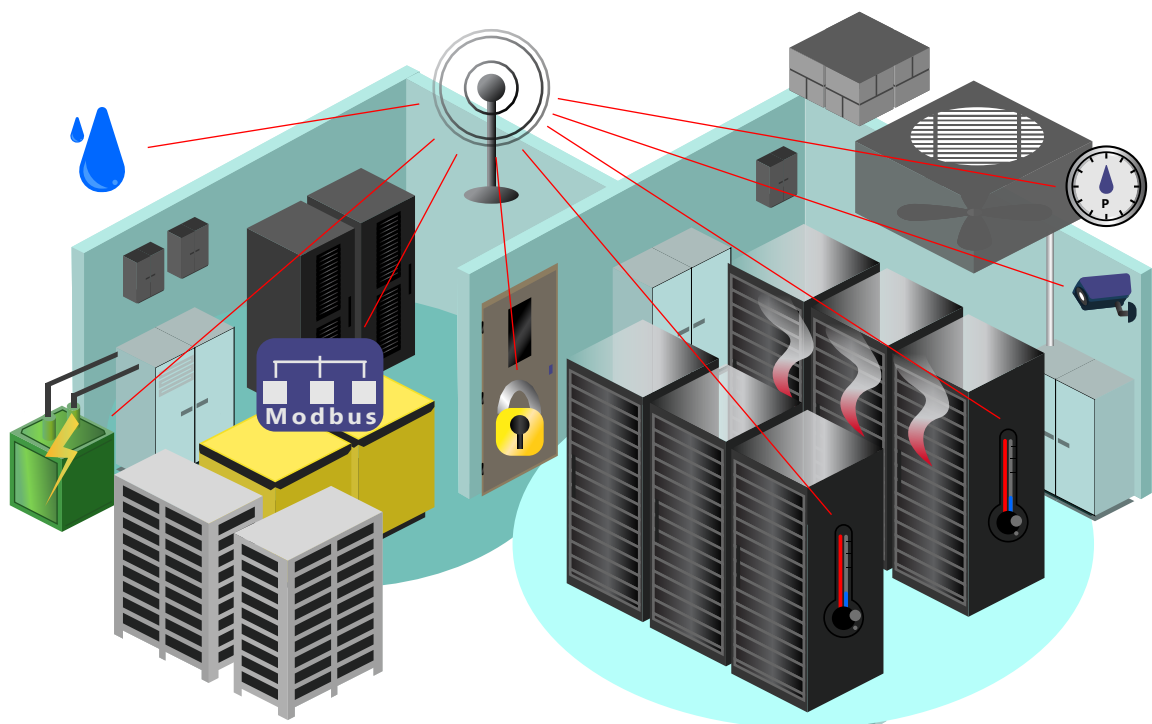

Data Center Monitoring - Rack Monitoring Solution

Complete rack monitoring system, with power metering, cabinet thermal maps, pressure differential and access control. Monitor single or multiple racks from the SPX+ built in web UI, or upgrade to AKCPro Server with analysis of where you can save energy in your data center.

- **Contactless Current Meter (CCM)**

Monitor current load to your cabinet. Check how close you are to tripping breakers, and calculate live PUE numbers. Power consumption of each rack is included in sensorCFD calculations.

- **Sensor Splitter Box (SSB)**

Interface box to connect thermal maps, pressure sensors and current meter to a single sensor port on the SPX+

- **Sensor Status Light (SSL)**

Sensor Status Light (SSL) Visual representation of cabinets status with green, orange and red status light

- **RFID Swing Lock (SHL)**

Control access to the cabinet, monitor door status, generate access reports and monitor side panels for removal

- **Cabinet Thermal Map**

Check front and rear temperature and humidity at top, middle and bottom of cabinets, as well as front to rear temperature differential (ΔT). Data used for sensorCFD calculations.

- **LCD (LCD-TMP)**

LCD (LCD-TMP) LCD Display shows sensor data, status and includes built in temperature sensor

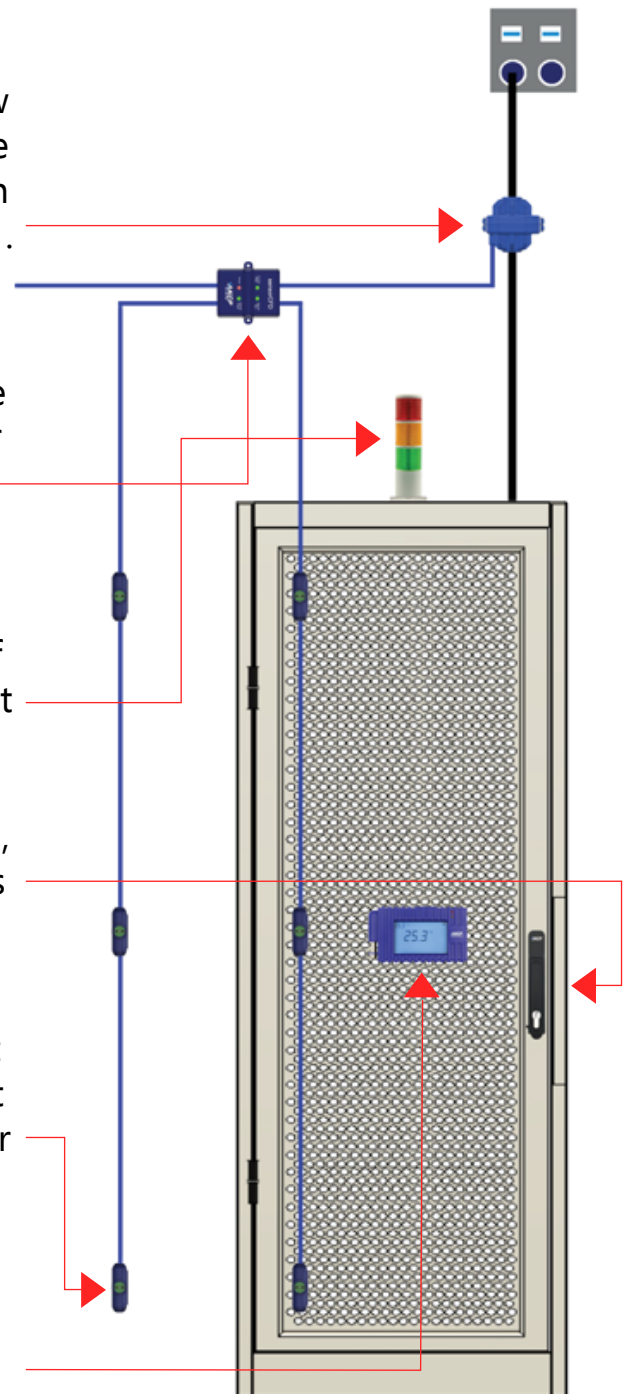

Data Center Monitoring - sensorCFD™

AKCP sensors are for more than simply monitoring and alerting when things go wrong. With 13 data points per rack covering temperature, humidity, pressure, ΔT , ΔP , and current, why not put that data to good use?

Traditional Computer Fluid Dynamics (CFD) modeling is usually done during the data center design phase. It is based on arbitrary values for the rack capacity, the cooling capacity. It makes many assumptions. But the data center is not static, it is dynamic. Power loads for racks go up and down with demand, cooling capacity adapts to the demands of the servers. Racks get moved, blanking panels left out, what was a sealed containment may be no more.

AKCP sensorCFD utilizes all the data gathered from the sensors on every rack, CRAC and plenum to produce a sensor constrained CFD analysis of the data center. Compare your performance to your original design, identify stranded capacity and areas of air mixing. Increase efficiency, lower carbon footprints and decrease operational expenses by fixing the identified problem areas.

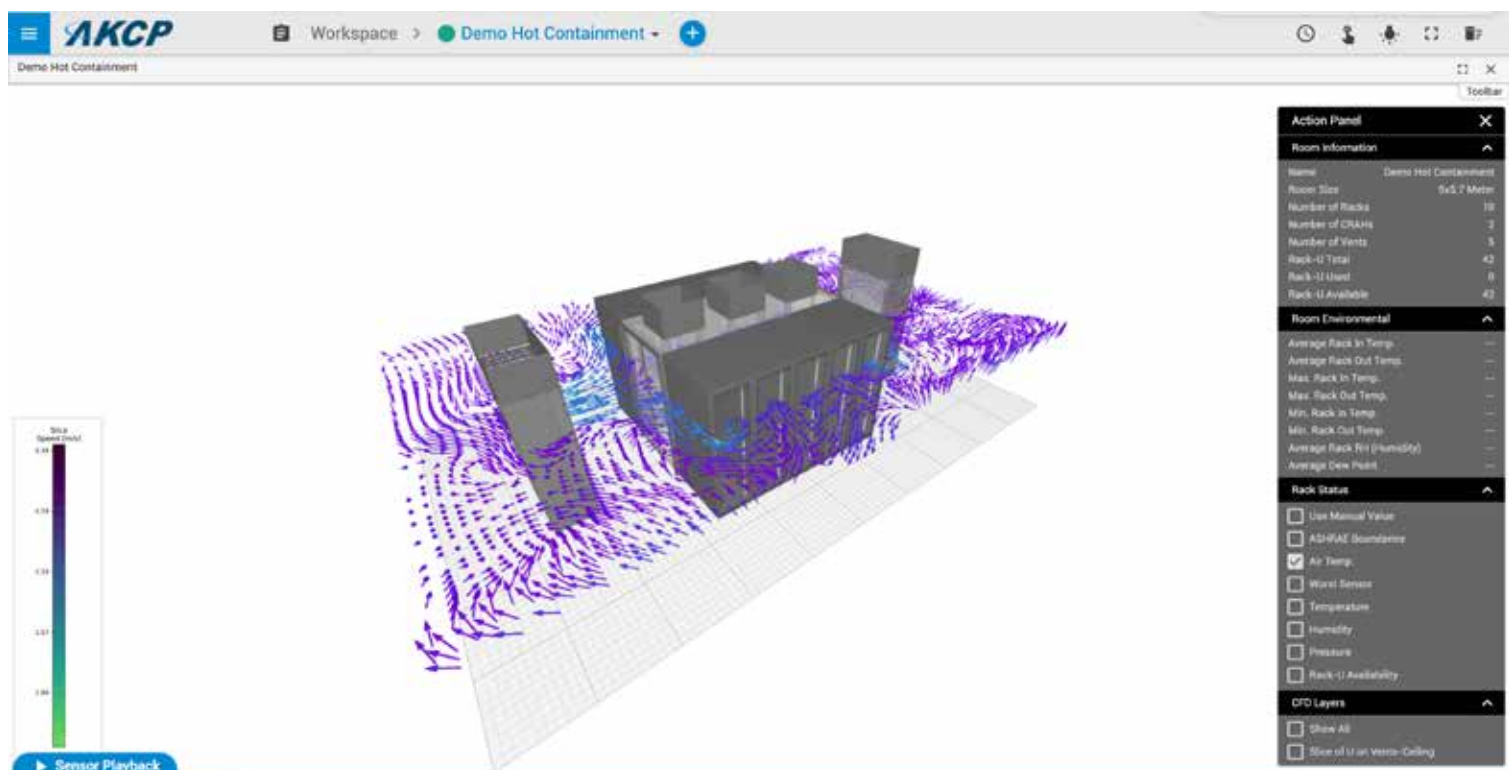

Cold Storage and Distribution

Cold storage facilities and cold chain distribution monitored utilizing the AKCP Wireless Tunnel™ sensor solution. Easy installation to monitor your complete cold storage facilities. From temperature and humidity monitoring, HVAC and refrigeration compressors, door security and full access control AKCP has you covered.

- Monitor temperature and humidity within cold storage rooms
- Check doors are closed, synchronize door events with CCTV camera feeds
- Monitoring of refrigeration systems, compressors and pressures
- Data logging wireless sensors in cold chain distribution trucks
- Realtime monitoring of trucks location and temperature over cellular network
- Integration to third-party equipment via SNMP or Modbus virtual sensors
- HVAC control and monitoring of pipe pressures and temperatures
- Monitoring from your cellphone, tablet or PC
- Private network with no recurring fees.

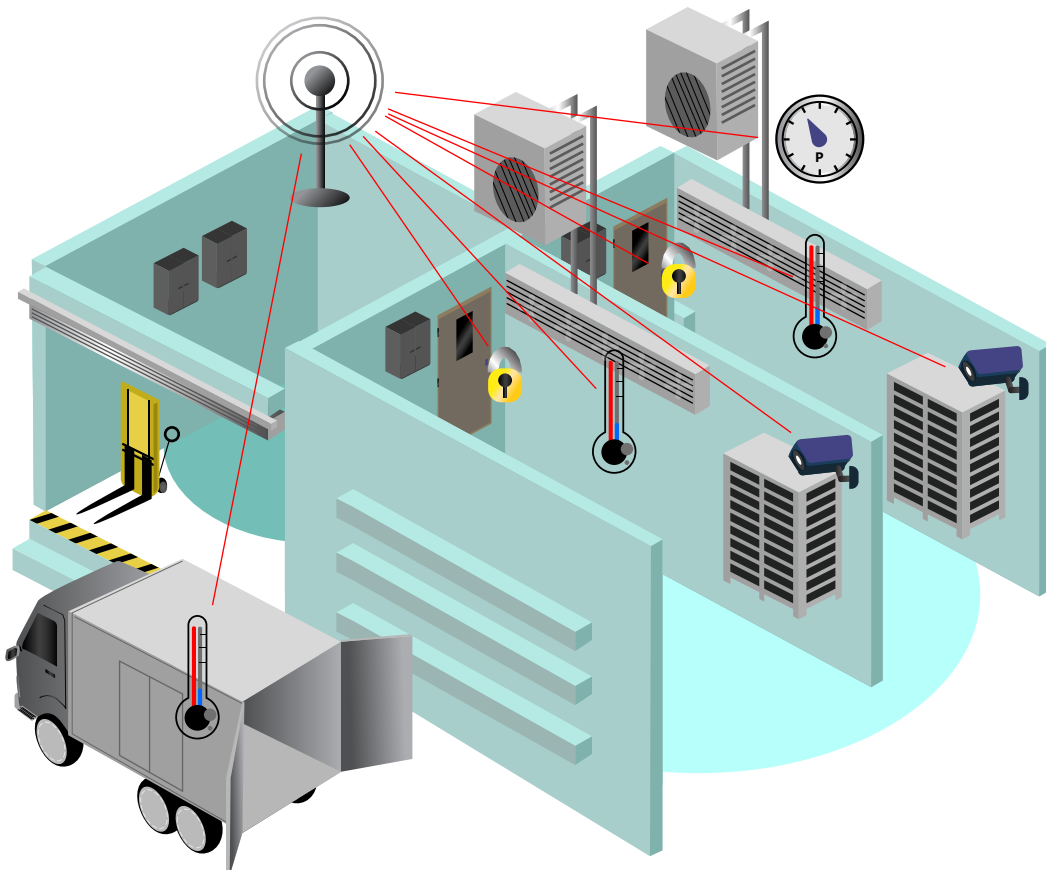

Cold Storage Monitoring and Data Logging

Monitor your cold storage facilities in real time, with delivery trucks logging data which synchronizes with the sensorProbe Wireless Tunnel™ Server when it returns to the depot.

Wireless Tunnel™ sensors feature internal logging of data and are battery operated. Simply place it in the truck upon dispatch and start logging data.

Wireless Tunnel™ Sensors monitoring temperature and doors communicate to Wireless Tunnel™ Server (SP-WTS). Monitor data online, receive alerts and view graphs of data.



Trucks with Temp and Humidity sensor connected to the sensorProbe Wireless Tunnel™ (SP-WT) logging data and synchronizes with SP-WTS

Cold Storage Monitoring and Live Tracking

Monitor your cold storage facilities and delivery trucks in real time. Wireless Tunnel™ Sensors monitor your cold storage facilities. Delivery vehicles are monitored live via cellular data connection with GPS.

Wireless Tunnel™ Sensors monitoring temperature and doors communicate to Wireless Tunnel™ Server (SP-WTS). Monitor data online, receive alerts and view graphs of data.

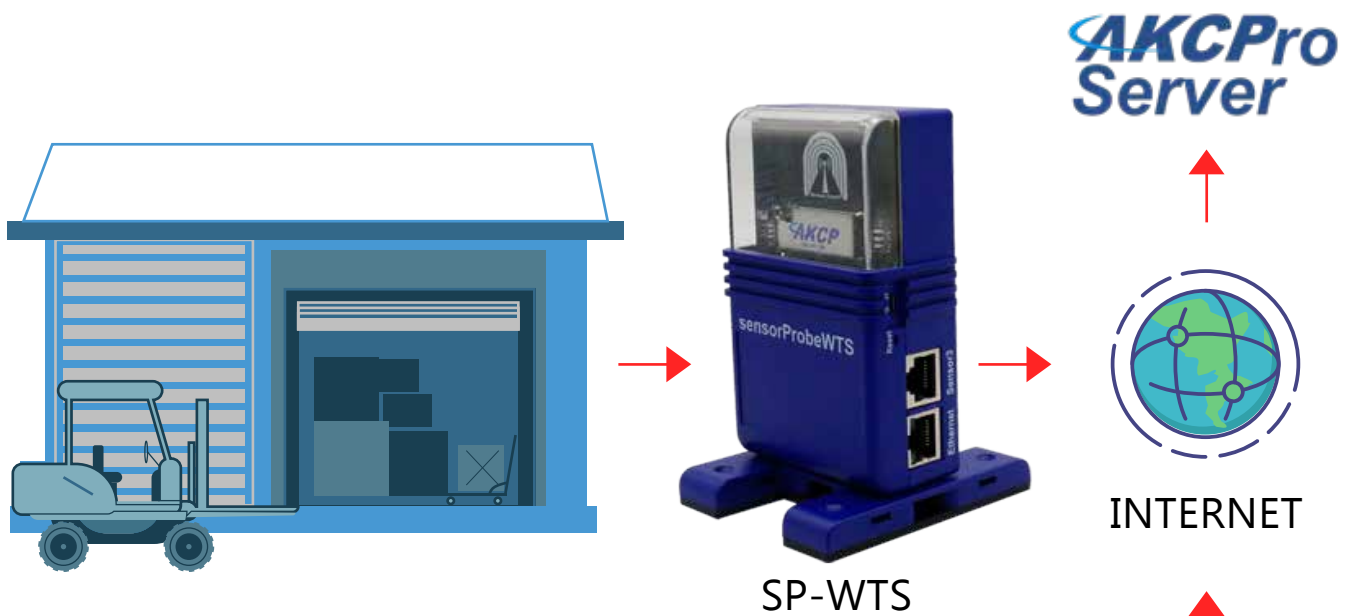

Trucks with Temp and Humidity sensors connected to the sensorProbe Wireless Tunnel™ (SP-WT) log data to SP-WTS equipped with cellular data modem and GPS. Communicate live data and location

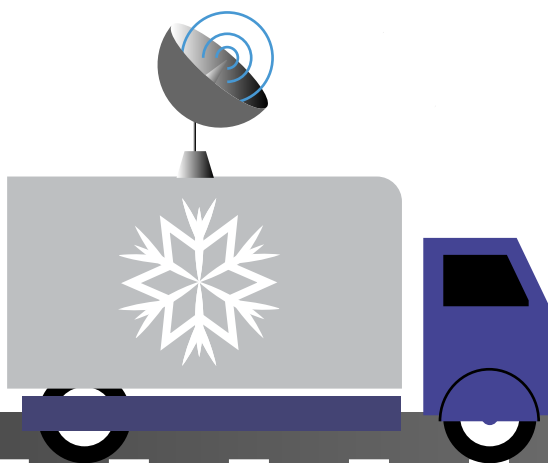

Customer - Naivas Cold Storage Monitoring



Naivas, Kenya's largest supermarket and online delivery service, selected AKCP Wireless Tunnel™ based monitoring system for quality control temperature and humidity monitoring of their cold storage environment.

Naivas, Kenya's largest supermarket and online delivery service, selected AKCP Wireless Tunnel™ based monitoring system for quality control temperature and humidity monitoring of their cold storage environment.

The project was done in conjunction with our dealer in Kenya, BSA (www.bsa.co.ke)

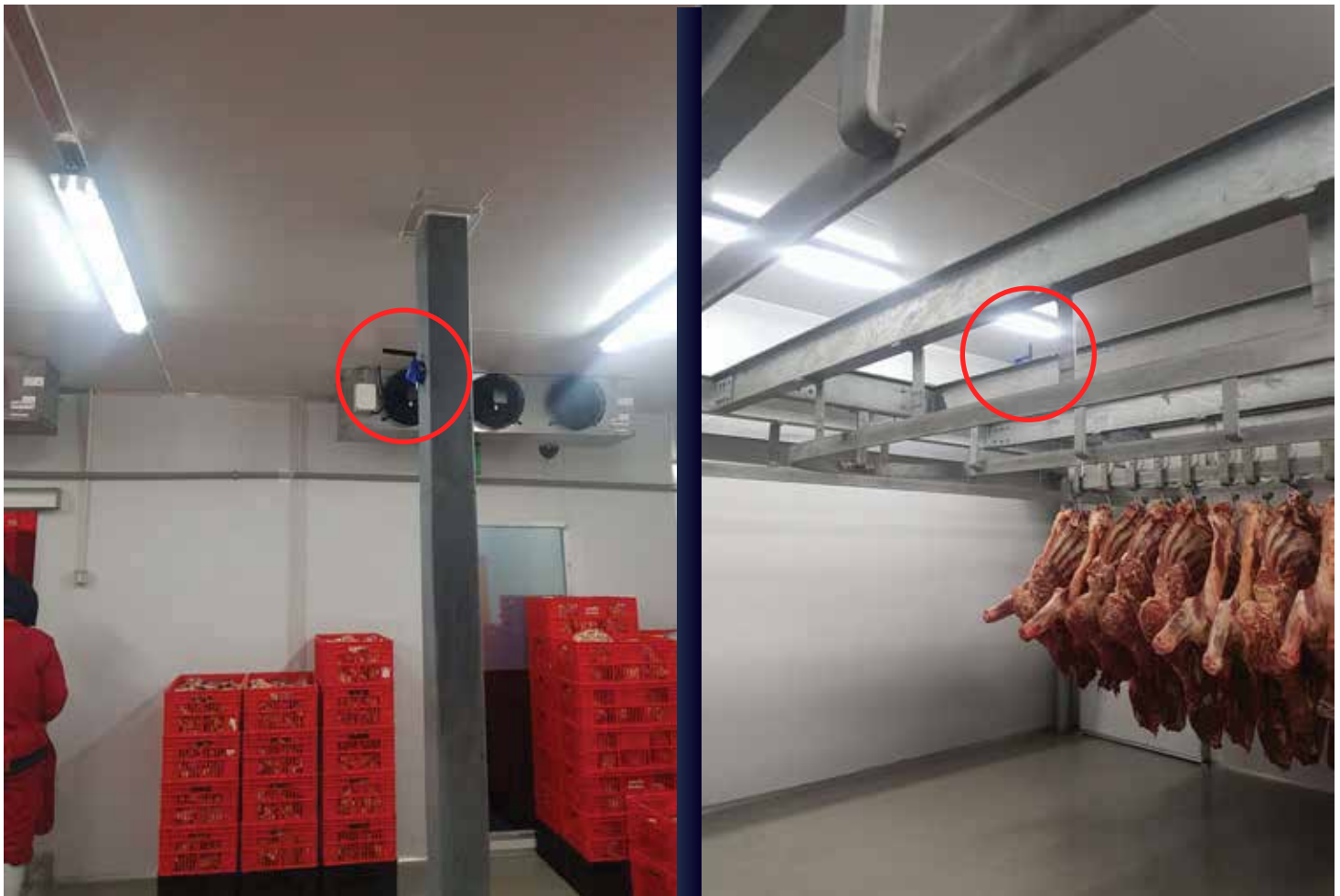

Warehouse Solutions

Warehouse environmental monitoring involves systematically observing and analyzing factors like temperature, humidity, and air quality within a facility to ensure optimal storage conditions.

Utilizing advanced sensor technologies, real-time data is collected to quickly respond to deviations. This practice not only enhances operational efficiency and minimizes the risk of product damage but also contributes to sustainability by optimizing energy usage. In essence, it plays a crucial role in maintaining quality inventory while promoting a safer and more environmentally friendly working environment.

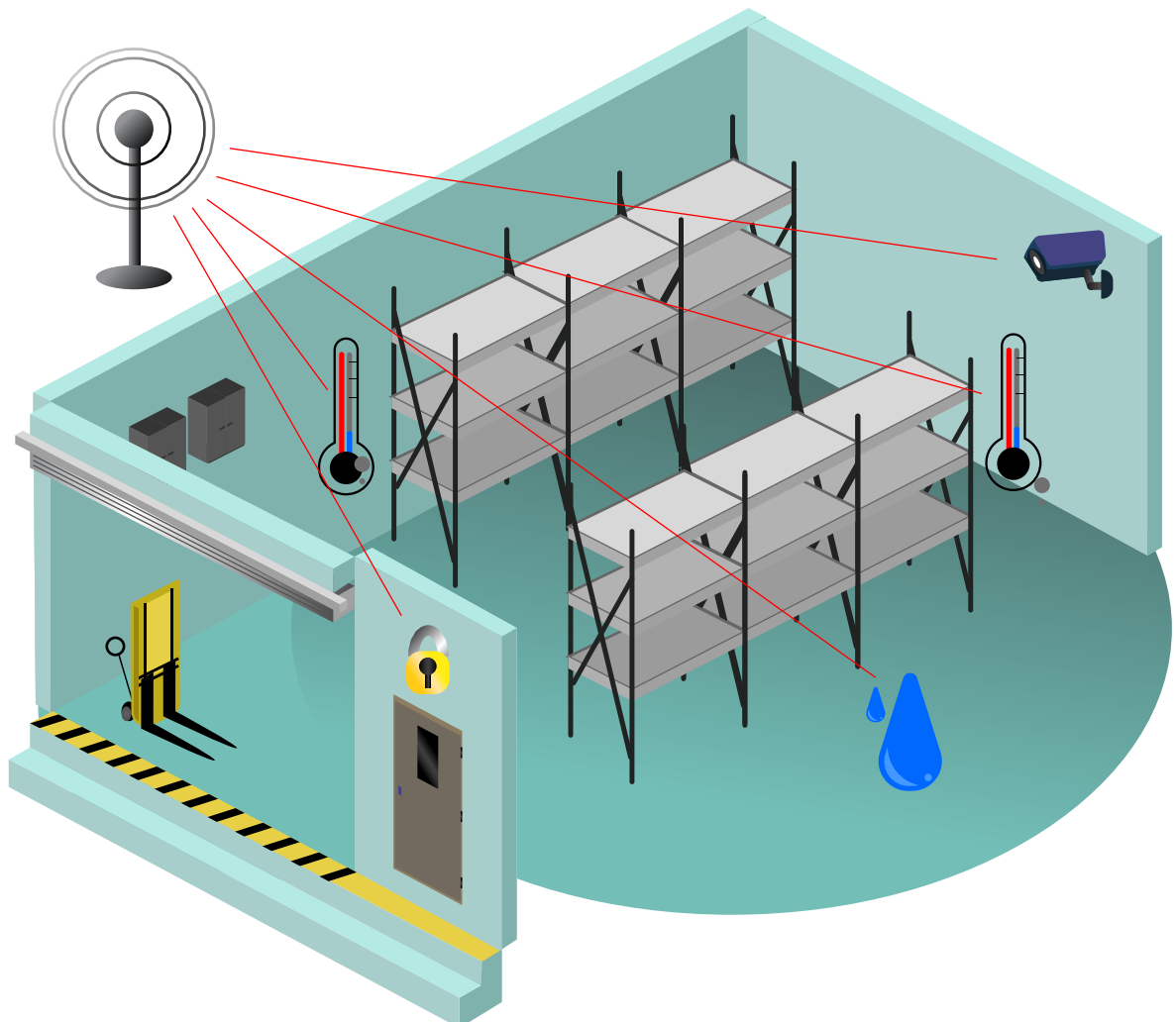

Wireless Warehouse Monitoring

Monitor correct storage temperature in warehouses. Graphing for traceability and reporting, with instant alerts when temperatures exceed defined parameters. Battery powered with up to 5 years battery life for safe, cable free environmental monitoring. Water leak monitoring is also critical to protect stock from damage.

Wireless Tunnel™ Sensors monitoring temperature and humidity of storage areas. Water leaks with rope water sensors are also monitored. Sensors are connected to the sensorProbe+ Wireless Tunnel™ (SP-WT)

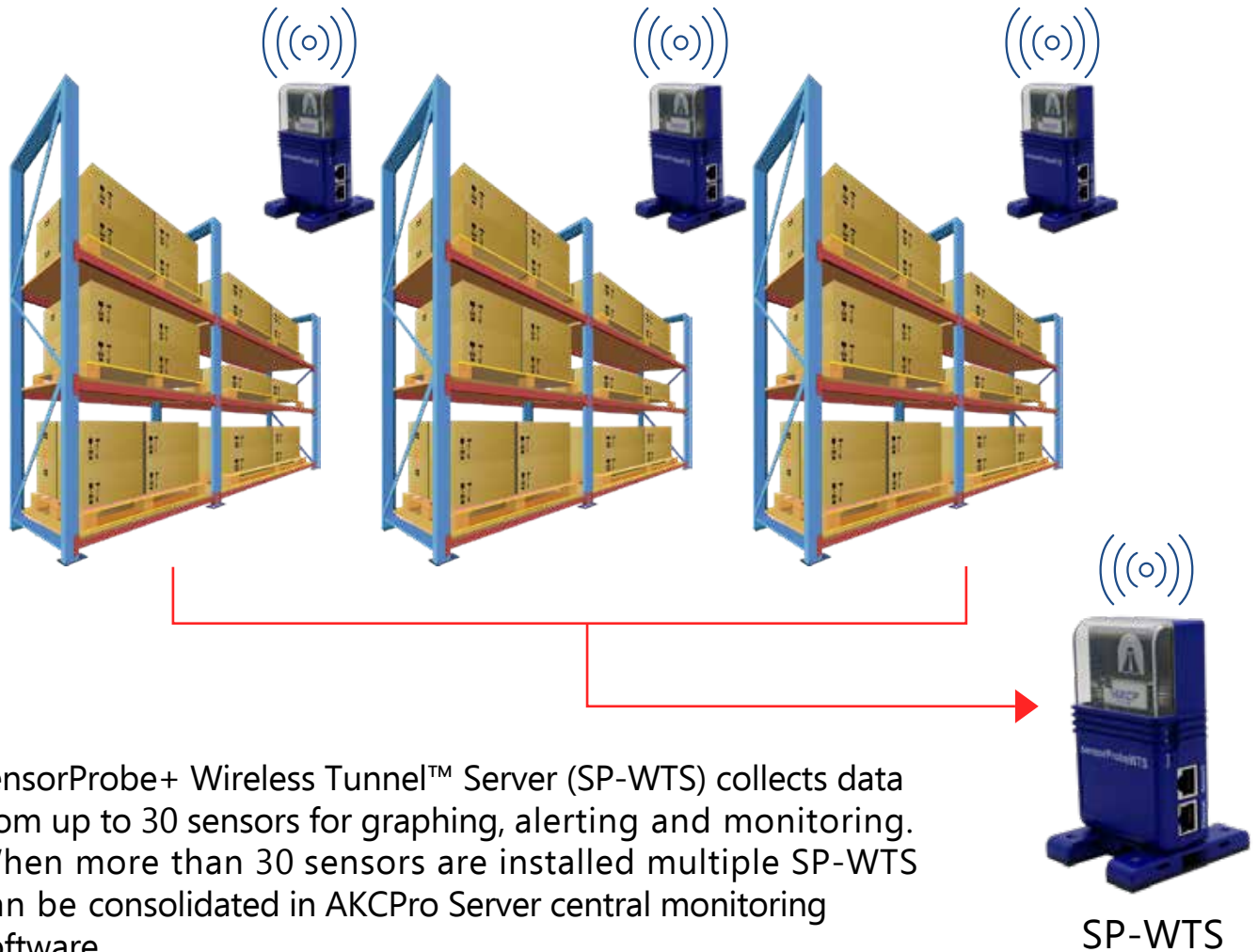

sensorProbe+ Wireless Tunnel™ Server (SP-WTS) collects data from up to 30 sensors for graphing, alerting and monitoring. When more than 30 sensors are installed multiple SP-WTS can be consolidated in AKCPro Server central monitoring software.

**AKCPro
Server**

Customer - Lufthansa Technik Warehouse Monitoring



Lufthansa Technik, the maintenance arm of the German airline Lufthansa, have selected AKCP monitoring devices for use in several of their maintenance hubs worldwide.

In the business of aircraft maintenance time plays a crucial role, and so does the timely supply of the mechanical, consumable and expendable spare parts, thus Lufthansa Technik keeps thousands of part numbers permanently in stock at each of their hubs.

There are industry regulations regarding the storage of many of these parts. There is a wide range of temperature and humidity thresholds for different parts, such as batteries, composites, oils or solvents. In order to constantly monitor the storage conditions AKCP technology has been deployed.

Lufthansa Technik Logistik Services (LTLS) implemented the AKCP environmental monitoring solution at their warehouses in Germany. The system is mainly based on the sensorProbe4 and sensorProbe8 devices.

These are coupled with single port dual temperature and humidity sensors, for general warehouse and humidity controlled areas, and the waterproof version, which is used to monitor cold storage areas. In addition to this, a GSM system based on the SP2+ with internal GSM modem is in place at remote warehouses that are not connected to the company's main network.



After the initial installation at their German warehouses, Lufthansa Technik have begun the installation at their other global locations. Sofia (Bulgaria) has already been installed, and now Aguadilla (Puerto Rico), Budapest (Hungary) and Shannon (Ireland) are to follow with similar setups at each, ensuring the warehouse teams have all the information they need to ensure the safe storage of aircraft materials.

Medical Monitoring

Laboratories, Pharmacies and Hospitals are required by government regulatory requirements to store vaccines, drugs and other materials in a monitored environment. Certain controlled drugs require secure cabinets and storage. Using the AKCP Wireless Tunnel™ solutions you can fulfill these monitoring requirements in a simple to install system. WirelessTunnel™ technology gives excellent penetration through walls and refrigerators and even secured reinforced cabinets.

- Temperature and humidity monitoring in your drug cabinets and refrigerators
- Door contacts for synchronization of access events with video feeds
- RFID access control system for laboratories and secure storage
- Private network with no recurring fees, or cloud service optional
- Realtime monitoring over your cellphone, tablet or PC
- Battery powered sensors, no need for drilling holes in refrigerator
- Differential Pressure for Clean Rooms and Containment Rooms

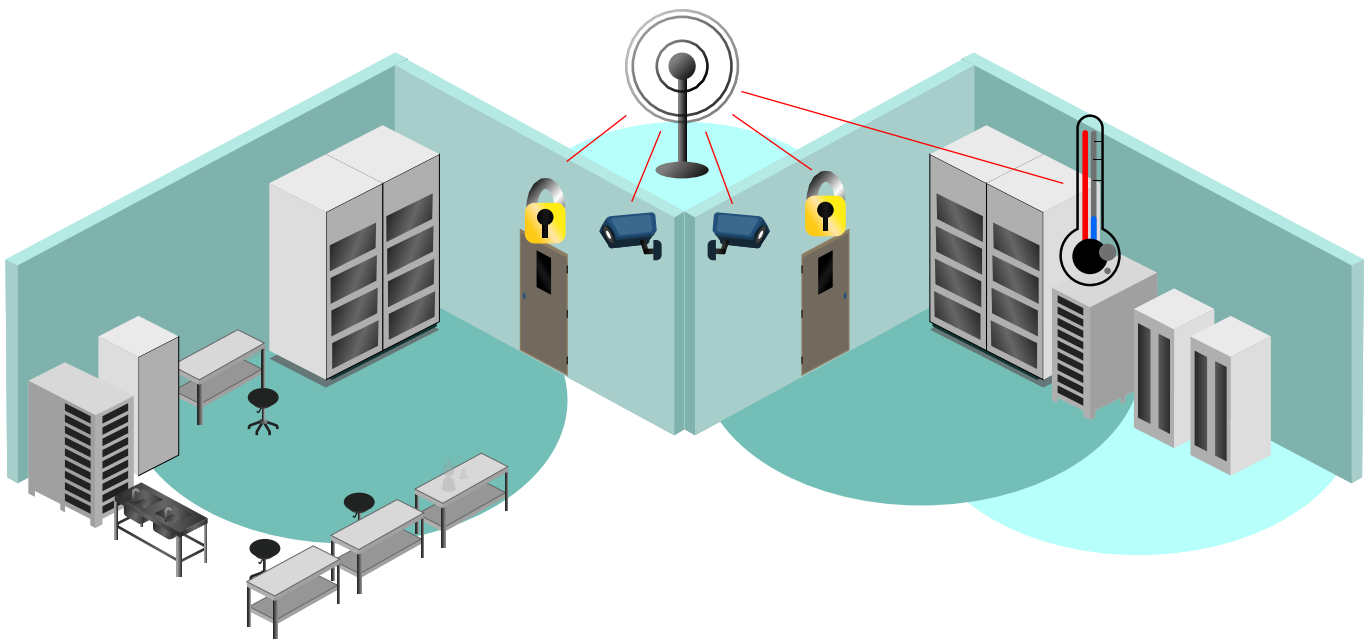

Vaccine and Temperature Sensitive Drugs

Vaccines and temperature sensitive drugs must be kept between 2°C and 8°C (35°F to 46°F) during transportation and while in medical refrigerators. AKCP have a complete solution for end to end monitoring of the supply chain, with data storage compliant with FDA 21 CFR Part 11.

Dual temperature sensor with calibration check

Temperature sensors are fully NIST traceable calibration certified. We build in 4 sensors to one device. These sensors act in pairs, checking each other for calibration. If we detect that one is out of calibration we seamlessly switch from one pair to the backup pair.

Ethyl Glycol Thermometer

To comply with regulations and best practices for vaccine and pharmaceutical refrigerator storage we have wireless temperature sensors paired with a jar of ethyl glycol to act as a buffer to air temperature fluctuations.

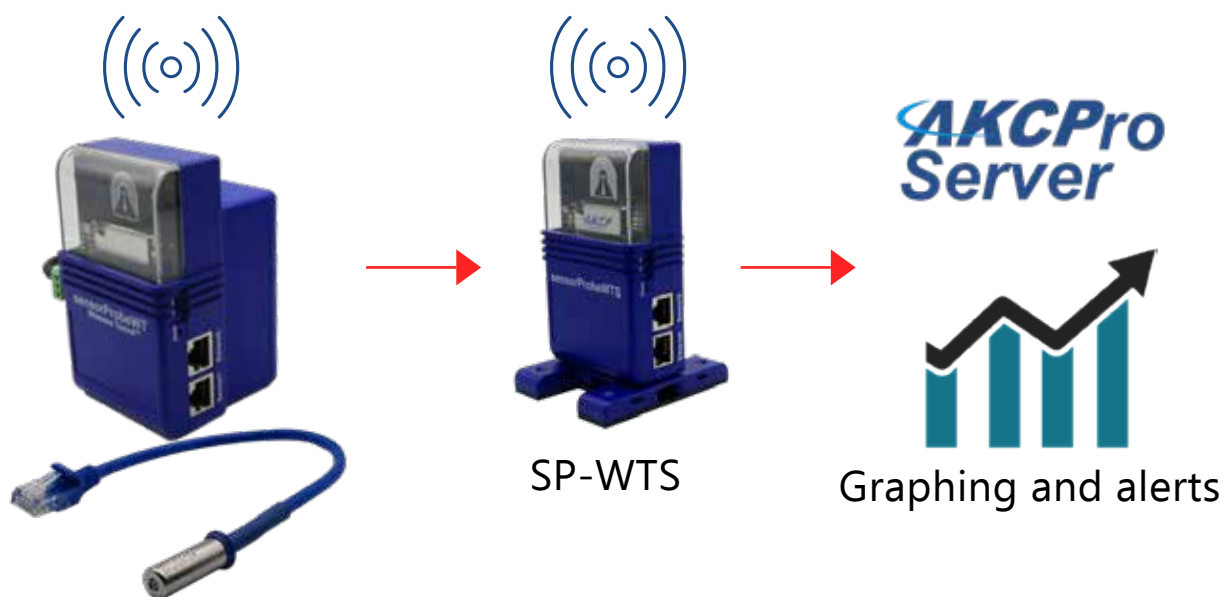

Clean Rooms and Containment Rooms

Clean and containment rooms are kept with a pressure differential between the inside and outside. Using AKCP differential air pressure sensors the rooms can be monitored for proper pressure gradient.

Clean Rooms

Clean rooms are kept at a positive pressure differential to the outside. This ensures that outside air is not sucked in, and any contaminants are expelled when doors are opened and closed.

Containment Rooms

Containment rooms, such as those housing infectious material are kept at a negative pressure differential to the outside. This ensures that contaminants are not expelled when doors are opened and closed.

Differential Air Pressure Sensor (DAP) connected with sensorProbe+ Wireless Tunnel (SP-WT)



HVAC Monitoring

Large building HVAC systems require monitoring to ensure proper and efficient operation. Regular and preventative maintenance saves money in expensive repairs and downtime. Battery powered Wireless Tunnel™ sensors can be deployed in difficult to reach areas that HVAC ducting and pipes are fixed.

- Modbus Wireless Tunnel™ interfaces your HVAC system to the AKCP platform
- Monitoring of compressor efficiency, heat and vibration
- Sensors measure pressure at important points in your HVAC system
- Temperature sensors on pipes for outgoing and return flow temperatures
- Integration to BMS systems via SNMP

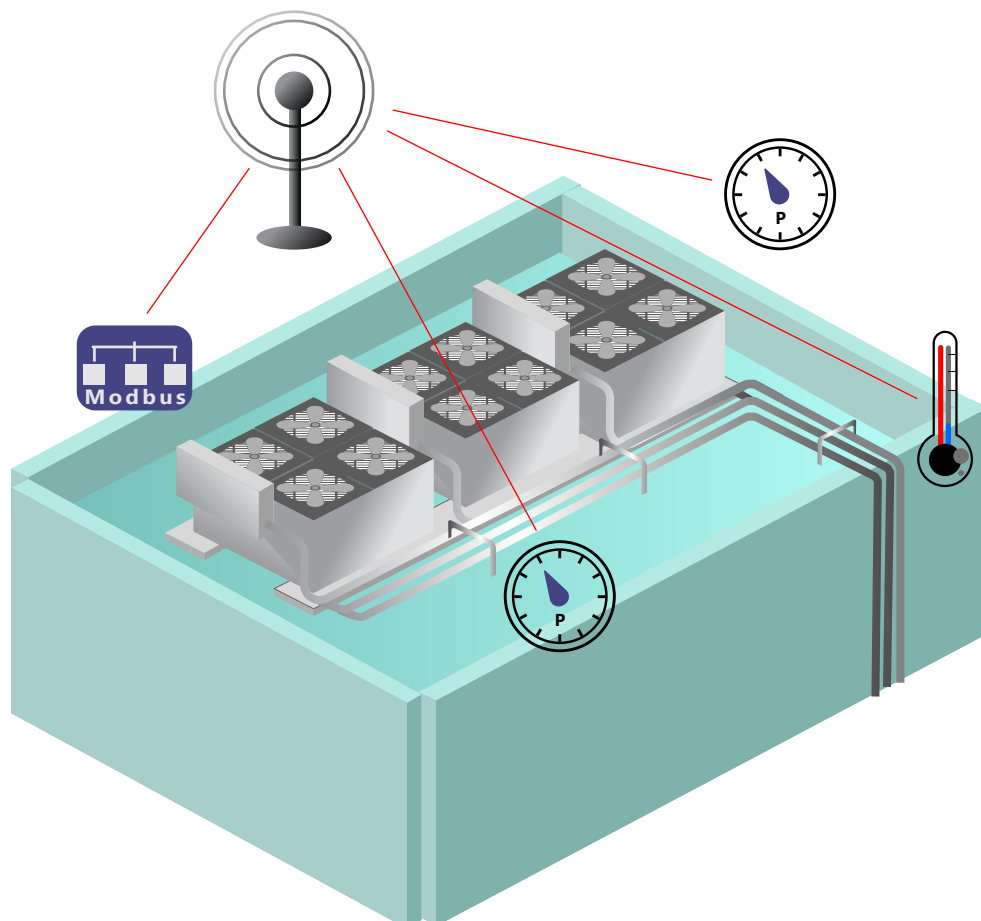

Customer - HVAC Monitoring in New Zealand

AKCP have installed monitoring for HVAC chillers at several locations in New Zealand. In these cases the HVAC systems had an old analog control system for the central plant. The SP2+ was deployed to add intelligence and remote monitoring capabilities to the installation. The SP2+ was selected for its compact size, low cost and rugged design.



The SP2+ interfaced to a Siemens flow meter through our isolated digital voltmeter. A dry contact input monitored the chiller fault alarm output, and two temperature sensors monitored the chilled water out and return flow temperature. A customized dashboard display was setup in the SP2+ web UI. The AKCP monitoring solution provided the end user with a simple and low cost upgrade path to bring intelligent HVAC monitoring to their building and facilities management system.



Solar and Battery Monitoring

Monitor solar panels for efficiency, and battery health. Solar panels require cleaning, proper alignment and loose efficiency over time. By monitoring their output voltage and current it can help with maintenance schedules.

Monitoring the power output of panels, and the current draw of battery banks will ensure you have sufficient panels to keep charge. Monitor voltage output and replace battery cells that are not holding charge and supplying enough voltage.

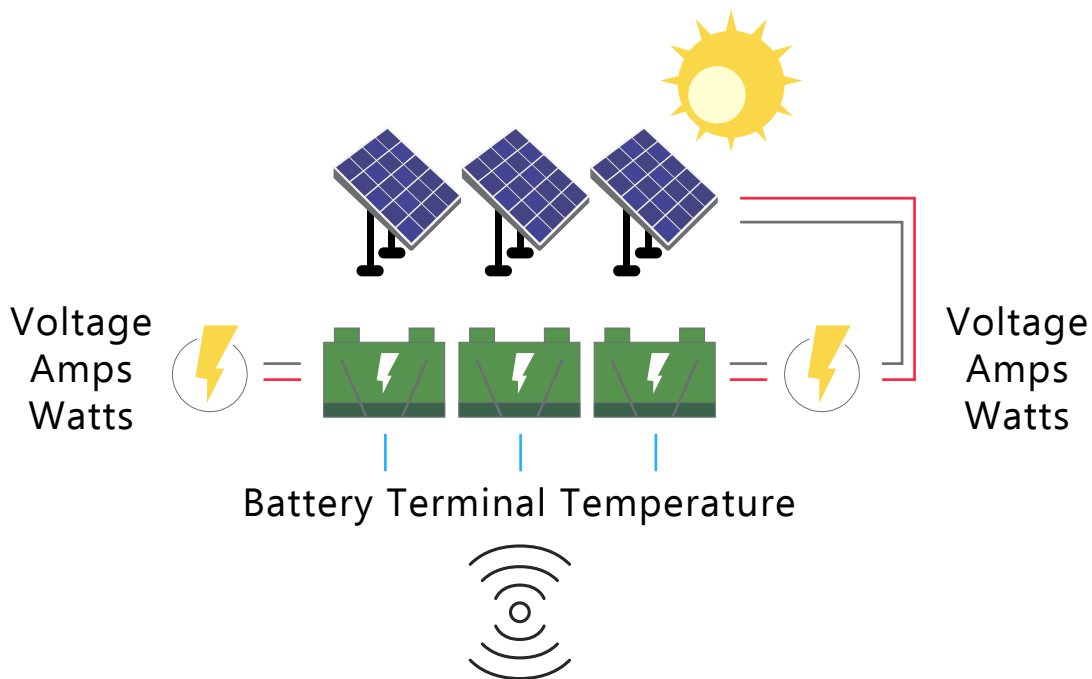

Solar and Battery Monitoring

Battery monitoring (BATTMON) sensor connected with sensorProbe Wireless Tunnel™ check solar panel and batteries for current and voltage.



Generator and Fuel Monitoring

Improve your generator performance, and cut operational costs with a generator monitoring system. Online generator monitoring will ensure that standby and backup generators are always at the ready. Prevent faults that can be costly to repair or result in higher fuel consumption.

Optimize your generator, check runtime and be reminded of maintenance schedules. Extend the life of your engine.

AKCP has sensors for monitoring power, battery voltage and current, runtime hours and fuel level. In addition, we can interface to control panels with Modbus RS485 or SNMP for more detailed data.

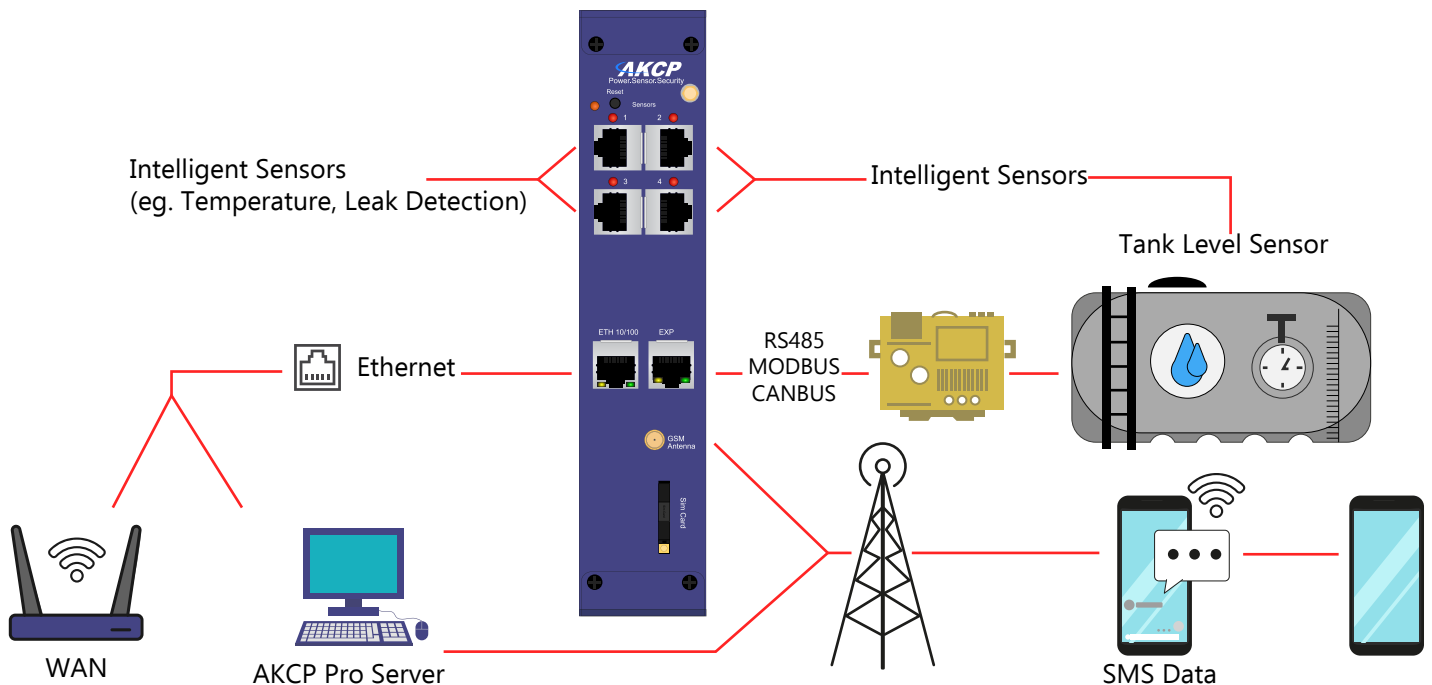

Generator and Fuel Monitoring

Real-time generator monitoring and attached sensors. An engine gauge dashboard presents the parameters in a graphical, easy to read format. For installations at multiple sites, AKCPro Server manages all your devices from a single user interface. Centralized monitoring of your infrastructure. Mapping of each site and their locations with zoom in to specific sites. Integration with ONVIF IP cameras gives "eyes on" at each site, with video synchronized with sensor events. AKCP's access control solution can be deployed to manage access at each site and is also administered through this central management software.

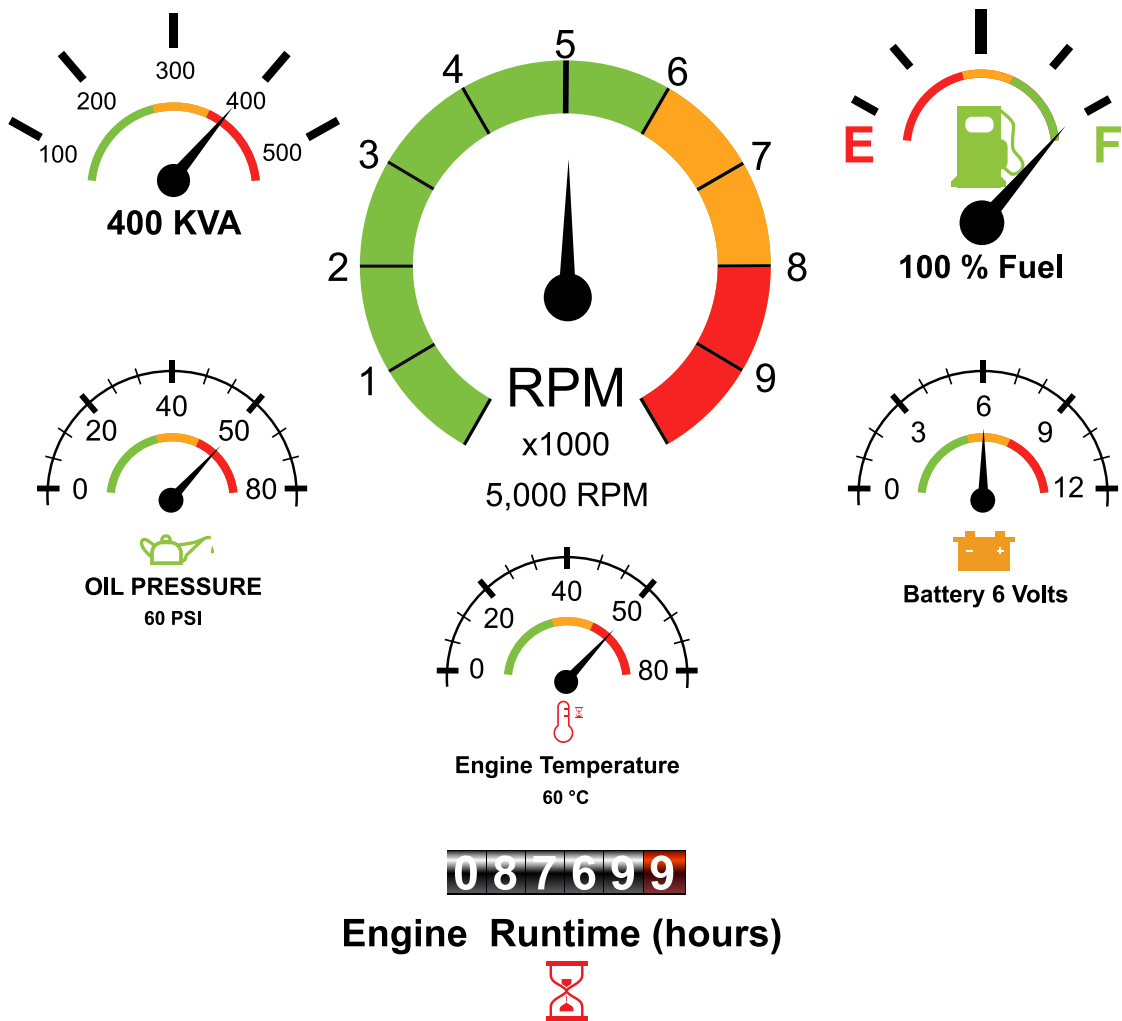





sensorProbe+ Series

Customizable Sensor Monitoring Devices

sensorProbe+ series include SNMPV3 and support for encrypted e-mail. Unlock additional software features such as IPV6, Radius and TACACS.

sensorProbe+ supports all AKCP sensors and are available with options such as PoE, Modbus RS485 and internal 4G cellular data modems.

	Name	Code	Description
	sensorProbe1+	SP1+B	1 port monitoring device with 1x Dry Contact I/O, PoE and built in temperature sensor. Basic version can be upgraded to Pro. Optional built in dual temp and humidity sensor.
	sensorProbe2+	SP2+B SP2+E	2 port monitoring device with additional 2x ports locked 3 port sensor monitoring device with 1x Modbus RS485
	sensorProbe2+ LCD	SP2+B-LCD	2 port monitoring device with additional 2x ports locked. Built in LCD display.
	sensorProbeX+ sensorProbeXN+	SPX+ SPXN+	Customizable modular sensorProbeX+ Standard hardware configuration with one time software license unlock for additional functions
	Internal 4G Modem External 4G Modem	M4E/M4U EM4G	4G cellular modem European/US Band (no voice call) External 4G modem, Global Band E-SIM (no voice call)

sensorProbe1+ (SP1+B / SP1+THS)

Simple, Yet Powerful Monitoring



SP1+B comes equipped with 1x intelligent sensor input and 1x dry contact digital I/O a hard wired temperature sensor on 5ft cable, and PoE as standard. Connect AKCP sensors such as temperature sensors, thermal maps and water leak detection.

The SP1+B comes with a basic set of software functions, which can be upgraded through a software license.

OPTIONS:

- **5VDC Power** - External power supply, used in combination with PoE as a redundant power input
- **Modbus RS485** - Convert the dry contact I/O input to Modbus RS485.
- **Mini Relay** - Convert the dry contact I/O to a mini relay
- **Dual Temp/Hum Sensor** - Convert the temperature sensor to dual THS.

SP1+B - Basic and Professional

The below table shows the features included with the SP1+ Basic, and the benefits of upgrading to the Professional license.



SP1+



SP1+B



SP1+PRO

	SP1+B	SP1+PRO
Dry Contact	—	—
Virtual Sensors	—	5
Event Log	✓	✓
Notifications	✓	✓
MQTTS	✓	✓
Graphs	✓	✓
Maps	—	✓
3rd Party Modbus	—	✓
IPv6	—	✓
SNMPV3	—	✓
VPN	—	✓
Access Control User	—	✓
RADIUS	—	✓
Heartbeats	—	✓
Modbus	—	✓
Cloud	—	✓
Authentication	—	✓

SP1+B / SP1+THS - Dual Power Inputs

SP1+B can be powered with dual inputs. PoE comes as standard, and an additional AC or DC source can provide primary power with PoE providing backup power. Or, in the absence of PoE dual inputs are available through our external DC-DC conversion box.

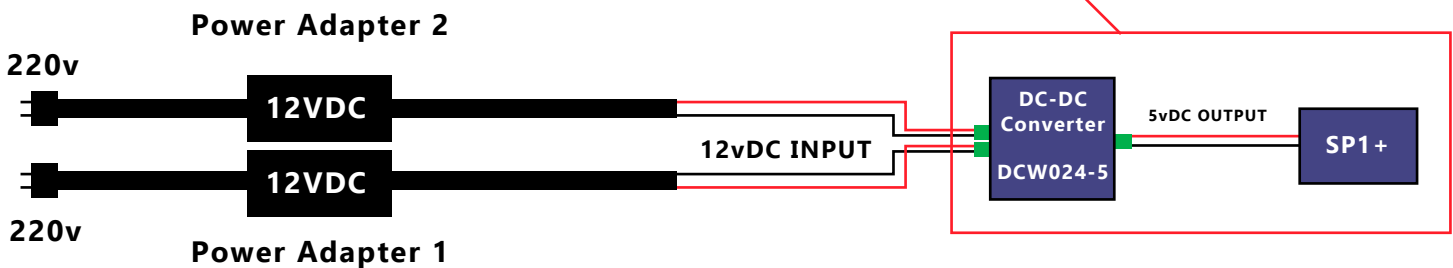
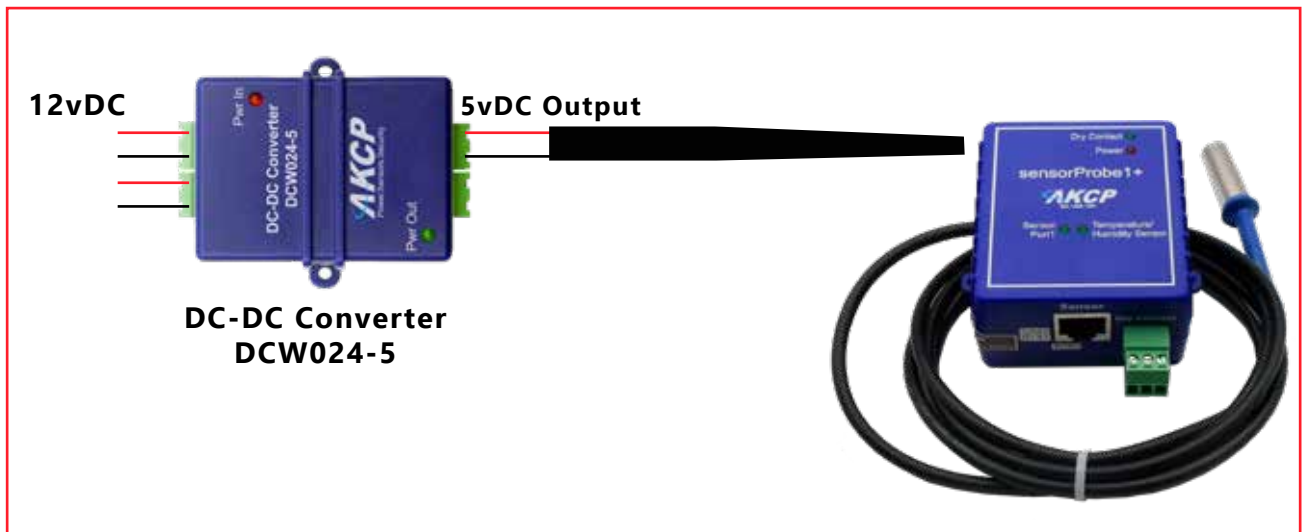

Example of dual / redundant 12VDC power input

SP1+B / SP1+THS- Technical Specification

Dimension	Size 82 x 72 x 35 mm Weight 0.2 Kg
Network Interface	Standard 10/100 Mbps Full Duplex Ethernet RJ45 Port
Mounting	Mounting Screw mounting Built in DIN Rail Clip and cable tie loops
Power Requirements	PoE IEEE 802.3af support Optional external 5.5V 3A Power Adapter Input Voltage and Current ratings : 100V~240V - 0.22A Optional external 12-24 or 40-60 VDC dual inputs
Status Indication	LED indication for Power LED for network connectivity LED for sensor online and threshold status LED for dry contact input status
RJ-45	1 RJ45 Sensor Ports for connecting AKCP Autosense Sensors
Components	Manufactured using highly integrated, low power surface mount technology to ensure long term reliability.
Operating Environment	Temperature : Min. 0°C - Max. 70°C (Industrial Option available for Min. -25°C - Max. 70°C) Humidity: Min. 20% – Max. 80% (Non-Condensing)
MTBF	1,400,000 Hours based on field experience with sensorProbe+ units.
Inputs	1x RJ45 Sensor Port 1x Dry Contact I/O (0/5VDC) 1x 10/100 Ethernet Port 1x hard wired 5ft temperature sensor / Dual temperature and humidity sensor (SP1+THS) 5x free virtual sensors (additional unlocked via license)
Outputs	Configurable output signals (0VDC/5VDC) on the 4 RJ45 sensor port
Max Sensors	Maximum of 400 onlined sensors, including virtual sensors.
Maximum Number of Access Control Users	500 Users 100 Users default
Protocols *Requires Pro License ** Requires Additional License	Rsyslog* MQTT / MQTTS* SNMP V1/2 /3 IPV6* RADIUS** TACACS** HTTPS Encrypted E-mail
5 Dry Contact	5 dry contact input sensor
Virtual Private Network (VPN)	VPN - Connect to AKCPro Server from your base unit through VPN over Ethernet or cellular network.
Virtual Sensors	Virtual sensor (pack of 5 sensors). Maximum of 80 virtual sensors. Comes with 5 free virtual sensors.
500 Access Control user database	500 users for access control
IPV6	Support for IPV6 network addresses
Radius	Radius user authentication server connection. TACACS authentication to Radius. Requires license.

SP1+B / SP1+THS - Technical Drawing

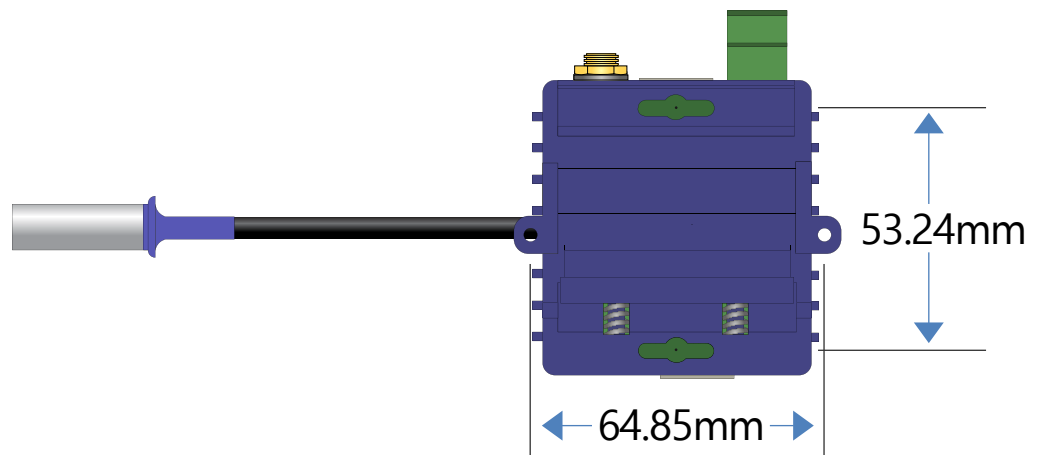
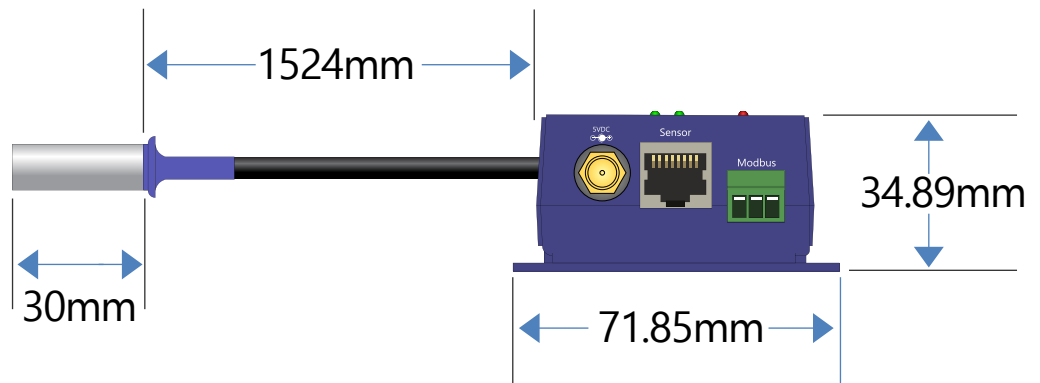
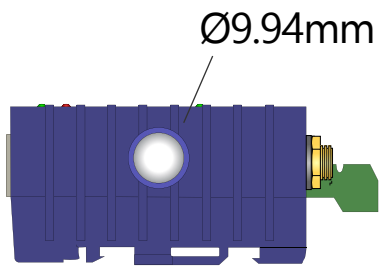
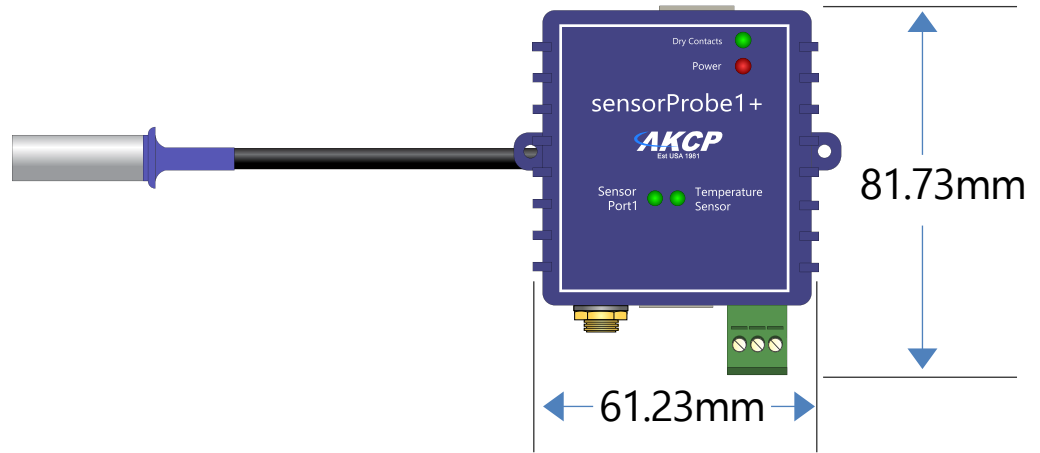

sensorProbe2+ (SP2+B / SP2+E)

Cost Effective and Versatile Monitoring



SP2+B comes equipped with 4x intelligent sensor ports to connect a wide range of AKCP sensors. 2x sensor ports are enabled by default, with a further 2 being unlocked with the one time Pro license upgrade. PoE is included as standard.

Additional security features can be unlocked such as support for IPV6 and Radius, SNMPV3 also with the Pro license upgrade.

Options include an internal 4G cellular data modem. If you have Modbus devices that you wish to monitor, such as a generator, or other industrial equipment, the SP2+ can be ordered with an RS485 port option (SP2+E).

OPTIONS:

- **EXP** - Port that is compatible with CCU, E-Opto16 and E-Sensor8 expansion units as well as doubling as a Modbus RS485 port.
- **4G Modem** - Cellular data communications, SMS alerts and phone call notifications.
- **External PSU** - Power the unit with external AC power supply, or use as a redundant power source with PoE

SP2+B - Basic and Professional

The below table shows the features included with the SP2+ Basic, and the benefits of upgrading to the Professional license.



SP2+



SP2+B



SP2+PRO

	SP2+B	SP2+PRO
Dry Contact	—	—
Virtual Sensors	—	5
Event Log	✓	✓
Notifications	✓	✓
MQTTS	✓	✓
Graphs	✓	✓
Maps	—	✓
3rd Party Modbus	—	✓
IPv6	—	✓
SNMPV3	—	✓
VPN	—	✓
Access Control User	—	✓
RADIUS	—	✓
Heartbeats	—	✓
Modbus	—	✓
Cloud	—	✓
Authentication	—	✓

SP2+B - Dual Power Input

SP2+ can be powered via dual AC or DC inputs, providing redundancy for powering the device. The 12-24VDC or 48-60VDC external power supplies feature dual DC inputs with a single 5VDC output for powering the SP2+.

Ideal for telecoms applications where DC power comes straight into the cabinets. Or in a data center with dual PDU's. Utilize 2x 12VDC power adapters, one on each AC power source, connect them to the DCW024-5 with the output to the DC jack on the SP2+.

If you have the SP2+ with Power over Ethernet (PoE), this can function as a redundant power source. Should the mainline power fail the SP2+ will switch to using the PoE as an alternative power source to the DC jack input.

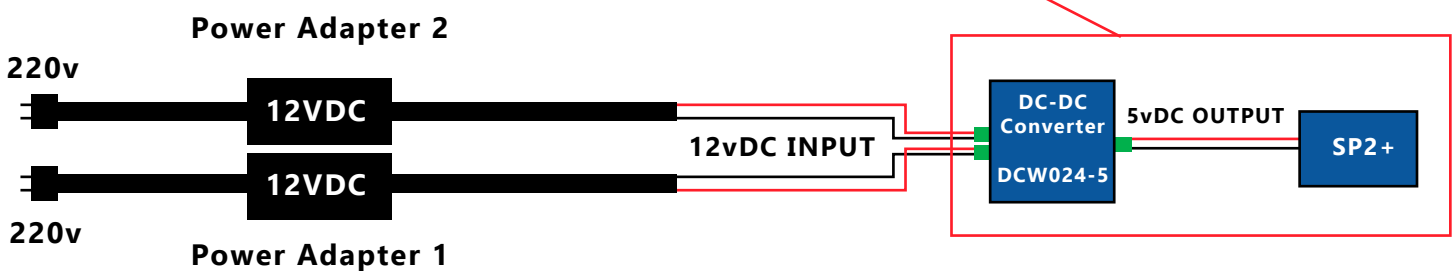
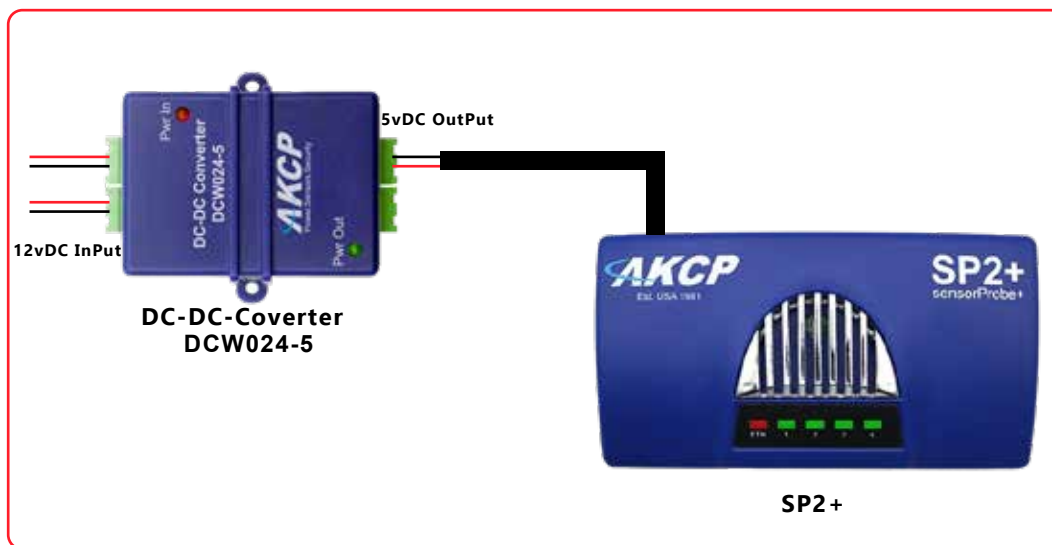

Example of dual power source for the SP2+

SP2+B / SP2+E Technical Specification

Dimension	Size 4.5" x 2.5" x 1.25" Weight 0.3 Kg
Network Interface	Standard 10/100 Mbps Full Duplex Ethernet RJ-45 Port
Mounting	0U rack-mountable Compatible with AKCP's DIN Rail Clips
Power Requirements	External 5.5V 3A Power Adapter Input Voltage and Current ratings : 100V~240V - 0.22A Optional PoE IEEE 802.3af support
Status Indication	LED indication for Power LED for network connectivity LED for sensor online and threshold status Internal Buzzer alarm
RJ-45	4 RJ-45 Sensor Ports for connecting AKCP Autosense Sensors Up to 20 Dry Contact Input and Output (0VDC/5VDC) Input Optional RJ-45 Expansion / Modbus RS485 Port
Components	Manufactured using highly integrated, low power surface mount technology to ensure long term reliability.
Operating Environment	Temperature : Min. 0°C - Max. 70°C (Industrial Option available for Min. -25°C - Max. 70°C) Humidity: Min. 20% – Max. 80% (Non-Condensing)
MTBF	1,400,000 Hours based on field experience with sensorProbe units.
Inputs	4x RJ-45 Sensor Ports (SP2+) 2x RJ-45 Sensor Ports with 2x additional locked under software (SP2-V2) 1x 10/100 Ethernet Port Optional 3/4G integrated cellular modem with external antenna (Optional GPS feature) 1 sensor port can be used as expansion port or Modbus RS485 on SP2+E version (supports up to 4 CCU, E-Sensor8 or E-Opto16) *
Outputs	Configurable output signals (0VDC/5VDC) on any of the 4 RJ-45 sensor ports
Max Sensors	Maximum of 400 onlined sensors, including Expansion Units and virtual sensors.
Optional Expansion Capabilities	See above * 1 sensor port can be used as expansion port or Modbus RS485 (on SP2+E version)
Maximum Number of Access Control Users	500 Users 100 Users default
Protocols *Requires Pro License **Requires Additional License	Rsyslog* MQTT / MQTTS* SNMP V1/2 /3 IPV6* RADIUS** TACACS** HTTPS Encrypted E-mail
Pro License Features	
5 Dry Contact: DC5	5 dry contact input sensor (per port) 1 License equals 1 RJ45 port unlocked
Virtual Private Network (VPN)	VPN - Connect to AKCP Pro Server from your base unit through VPN over Ethernet or cellular network.
Virtual Sensor pack: VS	Virtual sensor (pack of 5 sensors). Maximum of 80 virtual sensors. * ** Comes with 5 free virtual sensors
	3rd Party Modbus / PMS device.
3rd Party PMS & Modbus	Up to 4 modbus devices with 15 sensors.* ** 500 users for access control (SP+ series has 100 users as standard)
500 Access Control user database : UA	Support for IPV6 network addresses
IPV6: SP-IPV6	RADIUS user authentication server connection. TACACS authentication to RADIUS. Requires license.
RADIUS: RAD	* the sensorProbe+ units can only have 60 Modbus RS485 sensors (virtual sensor + modbus devices)
Important Notes	** the sensorProbe+ units can only have 60 Modbus TCP/IP sensors (virtual sensor + modbus devices)

SP2+B / SP2+E Technical Drawing

SP2+B with Internal Modem

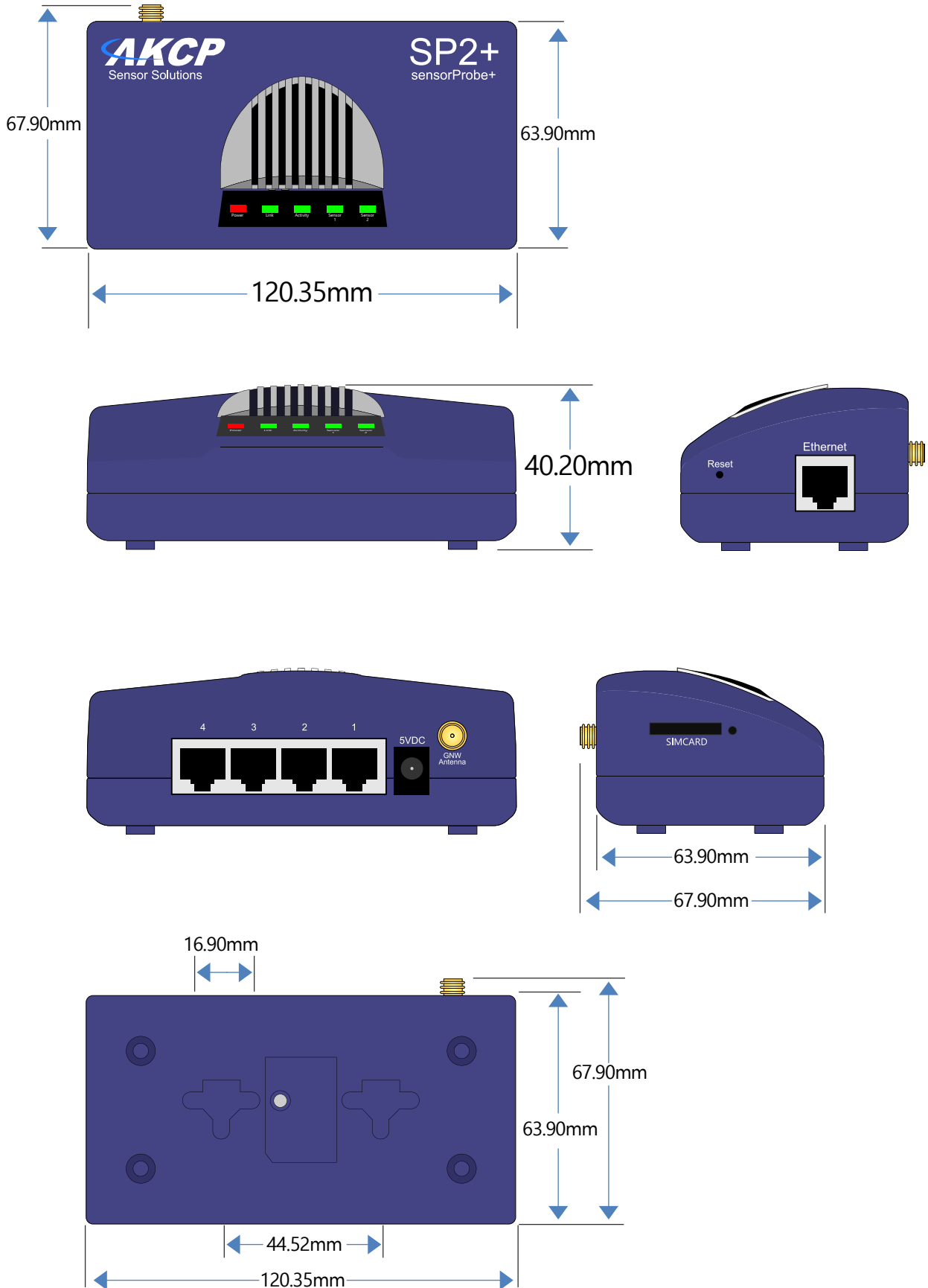

sensorProbe2+ LCD (SP2+B-LCD / SP2+B-LCD-MOD)



Sensor Monitoring with LCD Display

The SP2+B-LCD comes with hardware to support 4 sensor ports, Dry contact, built in PoE and LCD display to show data from connected sensors. The SP2+LCD Basic can be upgraded to the pro version with a one time software license.

Connect up to 4 AKCP sensors, including combined cabinet thermal maps and contactless current meters, providing up to 9 sensors per port.

OPTIONS:

- **4G Modem** - External cellular data modem plugs into dedicated UART modem port
- **External PSU** - Add a 5VDC external power supply for redundancy when combined with PoE
- **Modbus RS485** - Change the dry contact input to be Modbus RS485 (SP2+B-LCD-MOD)

SP2+B-LCD / SP2+B-LCD-MOD - Basic and Professional

The below table shows the features included with the SP2+LCD Basic, and the benefits of upgrading to the Professional license.



SP2+LCD



SP2+B



SP2+PRO

	SP2+B	SP2+PRO
Dry Contact	—	—
Virtual Sensors	—	5
Event Log	✓	✓
Notifications	✓	✓
MQTTS	✓	✓
Graphs	✓	✓
Maps	—	✓
3rd Party Modbus	—	✓
IPv6	—	✓
SNMPV3	—	✓
VPN	—	✓
Access Control User	—	✓
RADIUS	—	✓
Heartbeats	—	✓
Modbus	—	✓
Cloud	—	✓
Authentication	—	✓

SP2+B-LCD / SP2+B-LCD-MOD - Technical Specification

Dimension	Size 135 x 81 x 36 mm Weight 0.4 Kg
Network Interface	Standard 10/100 Mbps Full Duplex Ethernet RJ-45 Port
Mounting	0U rack-mountable Built in DIN rail mounting clip Screw hole mounting
Power Requirements	PoE IEEE 802.3af support External 5.5V 3A Power Adapter Input Voltage and Current ratings : 100V~240V - 0.22A
Status Indication	LCD display for sensor values, status and IP address LED indication for Power LED for network connectivity LED for sensor online and threshold status
RJ-45	4 RJ-45 Sensor Ports for connecting AKCP Autosense Sensors Up to 20 Dry Contact Input (5VDC) using 5DCS input for each sensor port 1x Dry Contact I/O + 4 optional, 1 I/O per sensor port
Components	Manufactured using highly integrated, low power surface mount technology to ensure long term reliability.
Operating Environment	Temperature : Min. 0°C – Max.70°C Humidity: Min. 20% – Max. 80% (Non-Condensing)
MTBF	1,400,000 Hours based on field experience with sensorProbe units.
Inputs	4x RJ-45 Sensor Ports 1x 10/100 Ethernet Port 1x UART external modem port
Outputs	Configurable output signals (0VDC/5VDC) on any of the 4 RJ-45 sensor ports
Max Sensors	Maximum of 400 onlined sensors, including virtual sensors.
Maximum Number of Access Control Users	500 Users 100 Users default
Protocols *Requires Pro License *Requires Additional License	Rsyslog* MQTT / MQTTS* SNMP V1/2 /3 IPV6* RADIUS** TACACS** HTTPS Encrypted E-mail
Pro License Features	
5 Dry Contact	5 dry contact input sensor (per port) 1 License equals 1 RJ45 port unlocked
Virtual Private Network (VPN)	VPN - Connect to AKCPro Server from your base unit through VPN over Ethernet or cellular network.
Virtual Sensor pack (VS)	Virtual sensor (pack of 5 sensors). Maximum of 80 virtual sensors. 5 virtual sensors included for free * **
3rd Party PMS & Modbus	3rd Party Modbus / PMS device. Up to 4 modbus devices with 15 sensors.* **
500 Access Control user database : UA	500 users for access control (SP+ series has 100 users as standard)
IPV6	Support for IPV6 network addresses
Radius	Radius user authentication server connection. TACACS authentication to Radius. Requires License
Important Notes	* the sensorProbe+ units can only have 60 Modbus RS485 sensors (virtual sensor + modbus devices) ** the sensorProbe+ units can only have 60 Modbus TCP/IP sensors (virtual sensor + modbus devices)

SP2+B-LCD / SP2+B-LCD-MOD - Technical Drawing

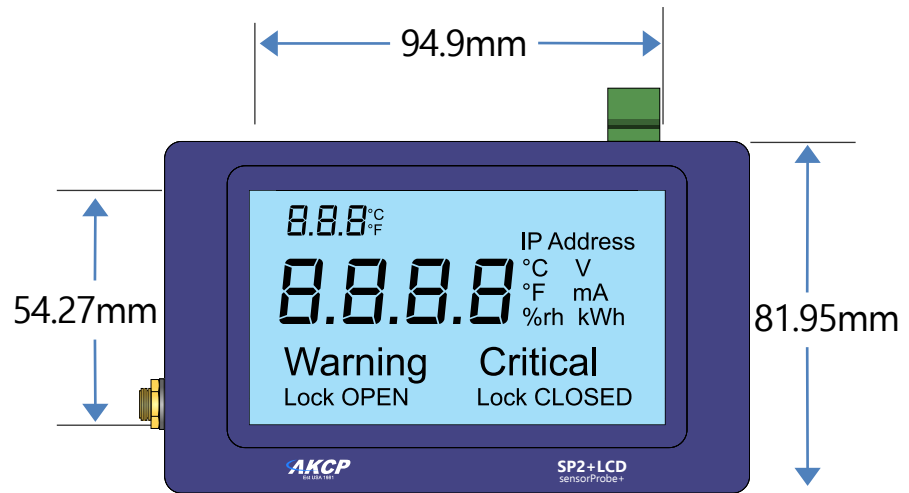
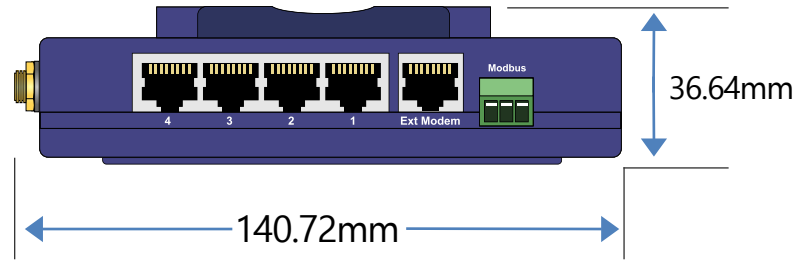
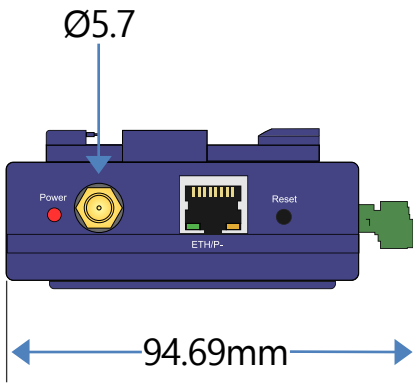
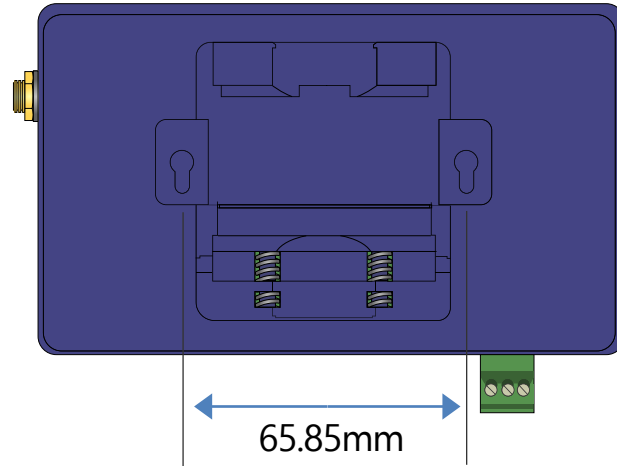

sensorProbeX+ (SPXN+ / SPX+)



Customizable Monitoring Standard and Modular Design

Select from a standard configuration (SPXN+), or build your own customized monitoring solution (SPX+). Choose a mounting option to suit your installation, whether it be 1U, 0U rack mounting, or DIN rail. Optional modules, internal DC power supply, PoE and Cellular modem can be selected depending on your requirements. Fully SNMP compliant with SNMP V1/2/3

SPX+ is compatible with all AKCP sensors, including the latest "smart sensors" such as swing handle locks, cabinet thermal maps, LCD display and battery monitoring sensors.

Every SPX+ features an EXP port, which functions as an RS485 Modbus port as well as connecting with AKCP Expansion modules.

A Basic Expansion Bus (BEB) port expands to additional SPX+ modules. A maximum of 4x BEB units can be connected to a single SPX+ Monitor multiple SPX+ units from AKCPro Server for centralized monitoring and management of all devices.

Mean Time Between Failure

Since its recent release, the SPX+ has grown to an installed base of approximately 5,000 base units. On average we have 4 hardware failures per year that require RMA replacement. That is to say that the SPX+ is operating for 43,800,000 hours for every 4 failures. That is a MTBF of 10,950,000 hours. The sensors have an approximately similar record of durability. The reason that this failure rate is so low is by design. The SPX+ was created for rugged environments. The components used in the SPX+ can withstand high-temperature environments because they generate very little heat. The SPX+ operates on 1 Watt of power.

This stands in contrast to larger systems running more complex, and less reliable operating systems such as Linux. Typical small computers often run at 300 Watts requiring a fan. The SPX+ doesn't need fans or special cooling. The case is built from Aluminum, not plastic. The SPX+ has been tested in environmental chambers to be able to operate reliably at 70° C. During the manufacture every SPX+ is tested, then burned in for 96 hours in order to eliminate infant mortality.

The system is put into stock awaiting a customer order. AKCP is not only rugged in hardware, it is rugged in software. Rather than relying on large, untested, and unmaintainable open source projects, we write our own applications. This is more difficult but results in superior performance. We can maintain the code because we wrote it ourselves. If there is a bug that needs fixing, we can fix it. If there is a feature that needs adding. We can add it. This is not possible in larger systems relying on third-party applications.

sensorProbeXN+ (SPXN+)

sensorProbeXN+ (SPXN+)



The SPXN+ is a standard 1U configuration of the SPX+. The configuration includes PoE), Modbus RS485 port and dedicated input for an optional external 4G cellular data modem.

The configuration of modules is:

- 8 sensor ports
- 10x dry contacts
- 2x 0-5VDC analog inputs
- 2x Mini Relays

The basic SPXN+ cost includes only 4 sensor ports activated. Additional sensor ports, dry contacts, A2D inputs and mini relays can be unlocked with a one time software license code. Order with required modules unlocked, or unlock in field as your needs dictate.

NOTE SPXN+ does not include :

- PSU or PSU Carriage (PoE comes as standard)
- BEB Port

SPX+ / SPXN+ Technical Specification

Dimension	44 (W) x 44 (H) low profile design
Expansion Port	EXP port connecting EXP Remote Units UART port for connecting external 4G modem
Mounting	1U rack mount brackets (standard) Optional 0U Toolless rack mount Optional DIN rail brackets.
Power	Power over Ethernet (PoE) as standard Optional External 5.5V 3A Power Adapter Input Voltage and Current ratings : 100V~240V - 0.22A
Status Indication	LED indication for power LED for network connectivity LED for sensor online and threshold status
Components	Manufactured using highly integrated, low power surface mount technology to ensure long term reliability.
Operating Environment	Temperature : Min. 0°C - Max. 70°C (Industrial Option available for Min. -25°C - Max. 70°C) Humidity: Min. 20% – Max. 80% (Non-Condensing)
MTBF	1,400,000 Hours based on field experience with sensorProbe units.
Base Unit	8x Sensor Ports for connecting AKCP sensors 10x Dry contact I/O 2x Mini relays 2x 0-5VDC inputs 1x Expansion Out or Modbus RS-485 Port (supports up to 4 CCU, E-Sensor8 or E-Opto16) 1x ART external modem port 1x 10/100 Mbps Ethernet Port
Max Sensors	Maximum of 300 onlined sensors, including Expansion Units and virtual sensors.
Maximum Number of Access Control Users	500 Users 100 Users default
Supported Protocols *Requires Additional License	Rsyslog MQTT / MQTTS SNMP V1/2 IPV6 RADIUS* TACAC*S HTTPS Encrypted E-mail
Licensing	
Virtual Private Network (VPN)	VPN - Connect to AKCPro Server from your base unit through VPN over Ethernet or cellular network.
Virtual Sensor pack: VS	Virtual sensor (pack of 5 sensors). Maximum of 80 virtual sensors. * ** Every SPX+ comes with 10 free virtual sensors. Additional available through license
3rd Party PMS & Modbus	3rd Party Modbus / PMS device. Up to 4 modbus devices with 15 sensors.* **
500 Access Control user database : UA	500 users for access control (SP+ series has 100 users as standard)
IPV6: SP-IPV6	Support for IPV6 network addresses
Radius: RAD	Radius user authentication server connection. TACACS authentication to Radius. Requires Radius License
Important Notes	* the sensorProbe+ units can only have 60 Modbus RS485 sensors (virtual sensor + modbus devices) ** the sensorProbe+ units can only have 60 Modbus TCP/IP sensors (virtual sensor + modbus devices)

SPXN+ Technical Drawing

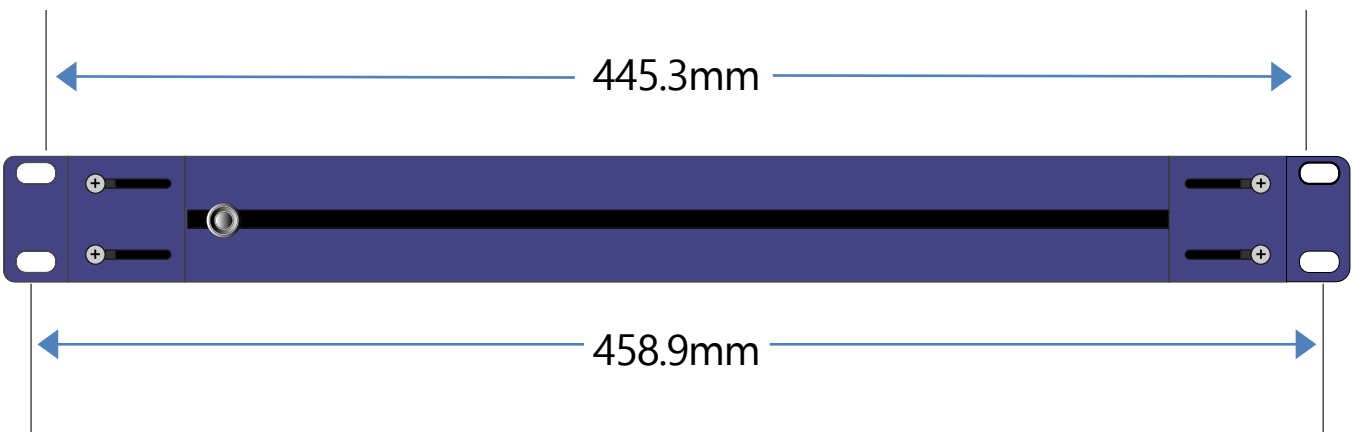
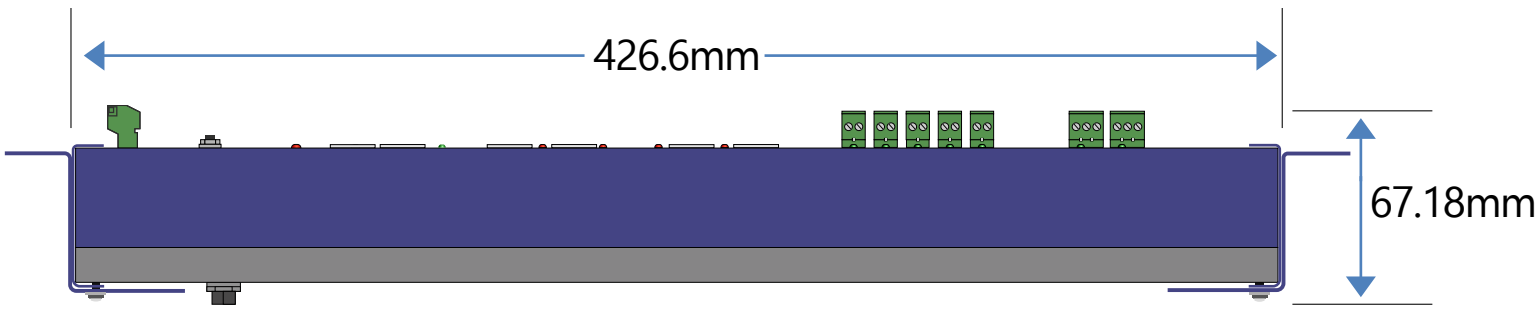
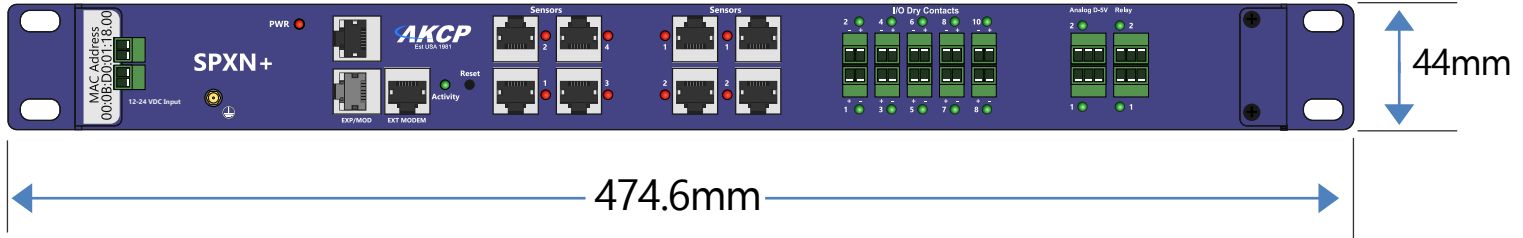

sensorProbeX+ (SPX+)

Customizable Modular Design

The SPX+ includes a Modbus and BEB port. Start with 4x sensor ports and add modules as required. Units can be built as short DIN rail mounted devices, 1U rack mounted or 0U mounting.

SPX+ Modules

MCU



The MCU Module is the core of the SPX+. A mandatory module it forms the base configuration of every unit. 4x intelligent sensor ports, Ethernet and a dual purpose Expansion (EXP) port for Modbus RS485 communications, or connection to AKCP Expansion. Basic Expansion Bus (BEB) port connects the SPX+ to SPX+ basic expansion units comprised of additional SPX+ modules.

sensor4

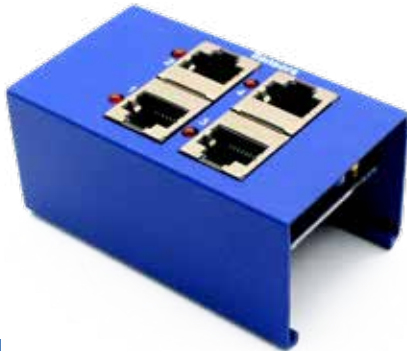

sensor4 modules give additional intelligent sensor ports, allowing you to build your SPX+ to your requirements. Connect a wide range of intelligent sensors and smartRack sensors such as Cabinet Thermal Maps, Programmable LCD Display and RFID Swing Handle Locks.

SPX+ - Modules

Dry Contacts

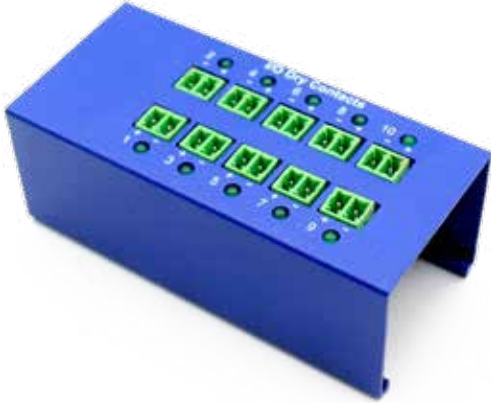

Dry contact modules can be added in x10 and x20 blocks. The dry contacts can be ordered as I/O, isolated input only (internal 5V) and isolated input only (external 5-30V). Dry contacts can be used to monitor a variety of third party devices and alarm panels.

Cellular Modem / GPS



4G Cellular Data Modem module gives a primary or backup method of communication. Send SMS and e-mail alerts directly from the device through the cell network. Ideal for remote site locations and those with unreliable DSL connection.

4x Mini Relays

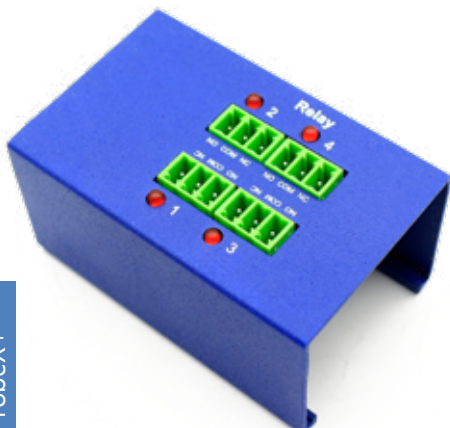

This module includes 4x mini DC relays. Use them to switch on/off low current devices directly, or use them to drive larger relays. Ideal for systems and control, building and industrial automation.

SPX+ - Modules

4x Analog to Digital Inputs



This module is ideal for connecting third party analog sensors with a 0-5VDC or 4-20mA scale output. Many industrial sensors are available with this scale output, opening up the possibilities of monitoring many different sensors not provided by AKCP.

2x Mini Relays & 2x Analog Inputs

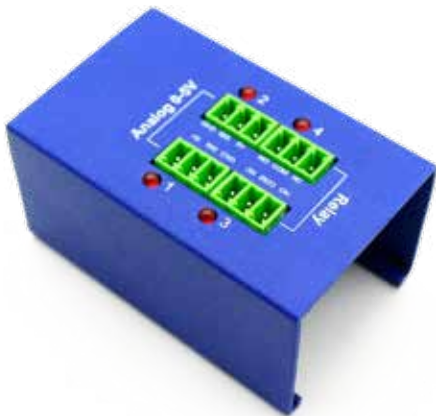

This module is a combination of the above modules, with 2x relays and 2x 0-5VDC or 4-20mA analog sensor inputs.

Internal Mini UPS



This module is useful in situations where the SPX+ may face power outages. An internal battery backup using 4x AA batteries can power the SPX+ for several hours (depending on sensors connected, alerts generated etc). This is ample time to be able to continue to send alerts, and most importantly notify you of the power situation so the main power can be restored.

Ideally combined with the internal cellular data modem, SMS alerts can be sent even if the rest of your network is down.

SPX+ - Modules

Internal Mini UPS

Mounting	Internal
Power	Input Voltage 5.5V 4x AA NimH batteries
Charger	Slow Charge circuit for long lasting batteries
Status Condition	Red LED indication for On Battery Status Green LED indication for charging status
Components	Manufactured using highly integrated, low power surface mount technology to ensure long term reliability.
Operating Environment	Temperature : Min. 0° C – Max. 70° C Humidity: Min. 20% – Max. 80% (Non-Condensing)
MTBF	1,400,000 Hours based on field experience with sensorProbe units.
Other	For SPX+ series only

Online Configuration

Customize your SPX+ with our online configuration tool, graphically build up your device with the modules you need and submit for quotation.

SPX+ - Expansion

Basic Expansion Bus (BEB)

Using an SPX+ Master with BEB, together with SPX+ Basic Expansion Bus devices, you can increase the number of sensor ports, and dry contacts available. Recommended for use over a short distance, within the same cabinet only, it provides a cost effective way to expand your system. The maximum distance from the SPX+ Master to the last unit in the chain is 10 meters.

- 4x BEB - Max total cable length 10 meters
- 3x BEB - Max total cable length 18 meters (3x 6m)
- 2x BEB - Max total length 20 meters (2x 10m)
- 1x BEB - Max total length 20 meters (1x 20m)

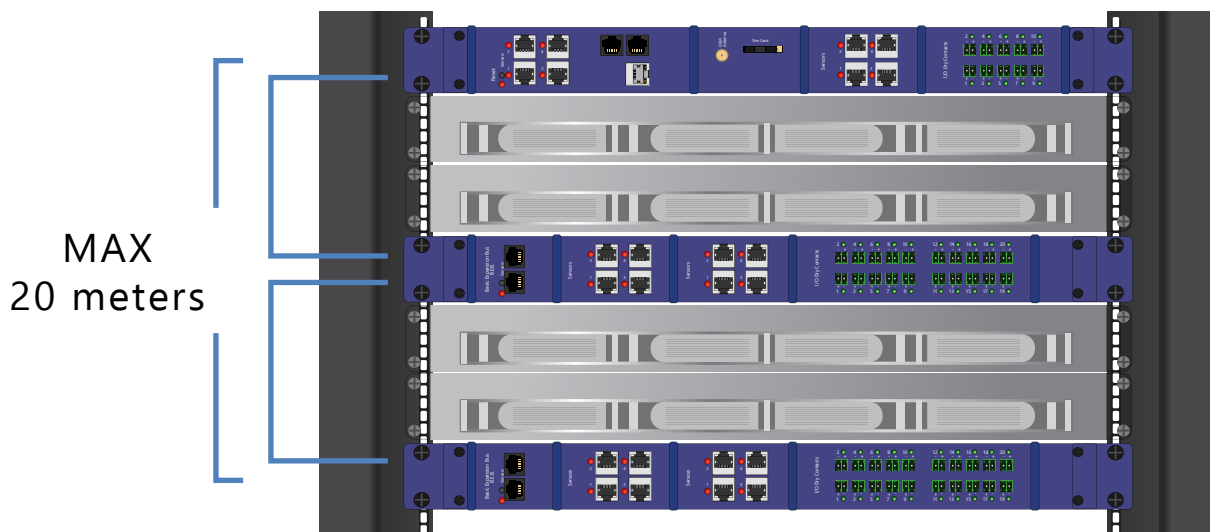

RS485 Expansion (EXP)

Using an SPX+ Master with EXP, together with EXP units you can add dry contacts and sensor ports to your system, with the ability to place the units up to 300 meters (1,000ft) away from each other. Supported EXP devices are the E-Sensor8 and E-Opto16 Expansion units.



SPXN+ / SPX+ - Dual Power Inputs

Dual Power Inputs

The SPX+ is available with an internal 12-24 VDC or 48-60 VDC power supply. This power supply features dual inputs with redundant fail-over. Ideal for telecoms where DC power is available directly in the cabinets.

It can also be utilized in a data center with a dual PDU setup. Connect the 220VAC-12VDC power adapters to the separate AC power sources, and the output of the 12VDC adapters to the SPX+.

If the SPX+ features the Power over Ethernet (PoE) option, this can also be used as a redundant power input. If the power source to the DC jack is interrupted the SPX+ will switch to the PoE source.

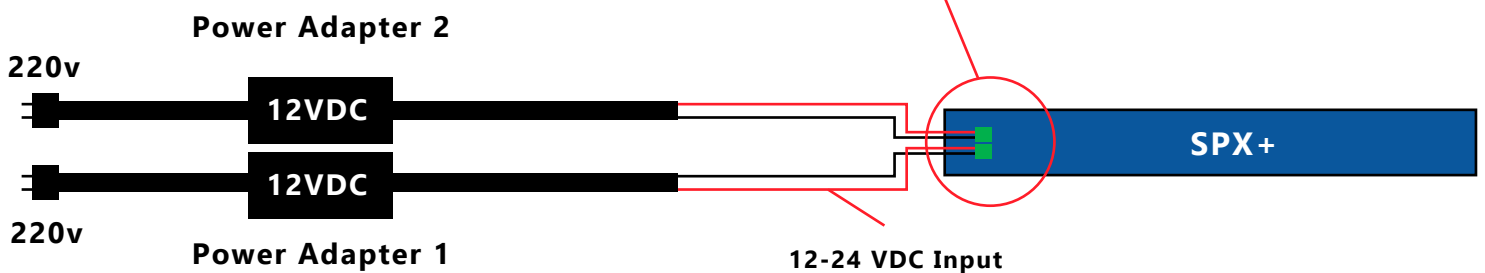

Example of dual power source for the SPX+

The dual DC inputs are also available as an external converter under product codes DCW024-5 and DCW048-5

SPX+ Technical Specification

Dimension	427mm (W) x 44mm (H) low profile design
Expansion Port	EXP port connecting EXP Remote Units BEB port for connecting SPX+ BEB Remote Units
Mounting	0U Toolless rack mount, optional wall mount brackets, horizontal 1U mounting or DIN rail brackets.
Power	External 5.5V 3A Power Adapter Input Voltage and Current ratings : 100V~240V - 0.22A Options: Power over Ethernet (PoE) Dual 12-24VDC internal power supply Dual 40-60 VDC internal power supply
Status Indication	LED indication for power LED for network connectivity LED for sensor online and threshold status Internal Buzzer for audible alerts
Components	Manufactured using highly integrated, low power surface mount technology to ensure long term reliability.
Operating Environment	Temperature : Min. 0°C - Max. 70°C (Industrial Option available for Min. -25°C - Max. 70°C) Humidity: Min. 20% – Max. 80% (Non-Condensing)
MTBF	10,950,000 Hours based on field experience with sensorProbe+ units.
Base Unit	4x Sensor Ports for connecting AKCP sensors 1x Expansion Out or Modbus RS-485 Port (supports up to 4 CCU, E-Sensor8 or E-Opto16) 1x Basic Expansion Bus Port (BEB) 1x 10/100 Mbps Ethernet Port
Max Sensors	Maximum of 150 onlined sensors, including Expansion Units and virtual sensors.
SPX+ Modules	- 4x Sensor Ports module for connecting AKCP sensors or swing handle cabinet locks - 10x or 20x Dry Contacts module, 3 configurations : + Configurable Input / Output dry Contact (0VDC/5VDC) + Input only 5V Dry Contact, opto-coupled input + Isolated input Dry Contact, from 5V to 30V voltage input signal + Isolated AC Detection input 5-30ACV @44mA - 4x Mini relays for driving larger relays - 4x 0-5VDC / 4-20mA input for third party sensors - 2x 0-5VDC / 4-20mA input for third party sensors with 2x Mini relays - Valve controller module
Optional	Internal mini UPS, 4x AA rechargeable batteries Internal 40-60V DC power supply 4G Cellular data modem with external antenna Power over Ethernet (PoE) Internal DC Power Supply
Maximum Number of Access Control Users	500 Users 100 Users default
Supported Protocols *Requires Additional License	Rsyslog MQTT / MQTTS SNMP V1/2 IPV6 RADIUS* TACACS* HTTPS Encrypted E-mail
Licensing	
Virtual Private Network (VPN) : VP	VPN - Connect to AKCP Server from your base unit through VPN over Ethernet or cellular network.
Virtual Sensor pack : VS	Virtual sensor (pack of 5 sensors). Maximum of 80 virtual sensors. * ** Every SPX+ comes with 10 free virtual sensors
3rd Party PMS & Modbus : PM	3rd Party Modbus / PMS device. Up to 4 modbus devices with 15 sensors.* **
500 Access Control user database : UA	500 users for access control (SP+ series has 100 users as standard)
IPV6 : SP-IPV6	Support for IPV6 network addresses
Radius : RAD	Radius user authentication server connection. TACACS authentication to Radius. Requires additional license
Important Notes	* the sensorProbe+ units can only have 60 Modbus RS485 sensors (virtual sensor + modbus devices) ** the sensorProbe+ units can only have 60 Modbus TCP/IP sensors (virtual sensor + modbus devices)

SP+ 4G Modem (M4E / M4U) - Technical Specification

Frequencies	<p>EU model :</p> <ul style="list-style-type: none"> • LTE-TDD B38/B40/B41 • LTE-FDD B1/B3/B5/B7/B8/B20 • UMTS/HSPA+ B1/B5/B8 • GSM/GPRS/EDGE B3/B8 <p>US model :</p> <ul style="list-style-type: none"> • LTE-FDD B2/B4/B12 • UMTS/HSPA+ B2/B5
Category	CAT1
Data Transmission	<p>HSPA+: up to 5.76 Mbps(UL), 42 Mbps(DL)</p> <p>LTE Category 1: up to 5 Mbps (UL), 10 Mbps (DL)</p>
Transmitting Power	<p>WCDMA: Class 3 (0.25W)</p> <p>LTE: Class 3 (0.25W)</p>
Features	<p>SMS</p> <p>Telephone Call with Text to Speech</p> <p>Internet (PPP) : email, VPN, cloud</p> <p>Optional GPS *</p> <p>+ GNSS: GPS/GLONASS/Beidou/Galileo</p> <p>+ GPS active antenna provided</p>
SIM card	<p>Standard SIM card size</p> <p>Support SAT class 3, GSM 11.14 Release 98</p>
Antenna	3m External Antenna
Components	Manufactured using highly integrated, low power surface mount technology to ensure long term reliability.
Operating Environment	<p>Temperature : Min. -20° C – Max.70° C</p> <p>Humidity: Min. 20% – Max. 80% (Non-Condensing)</p>
Certification	<p>EU Version :</p> <ul style="list-style-type: none"> • CE-RED • IMDA • GCF • RoHS • REACH <p>US Version :</p> <ul style="list-style-type: none"> • FCC • PTCRB • IC • RoHS • REACH
Carrier Certification	<p>EU version :</p> <ul style="list-style-type: none"> • Deutsche Telekom / Vodafone <p>US version :</p> <ul style="list-style-type: none"> • AT&T / Rogers
Important Note	<p>This modem will support telephone call text to speech and GPS in future releases</p> <p>* GPS support on SP2+ and SP-WTS only</p>

SPX+ Technical Drawing

SPX+ Standard Configurations

SPX4

SPX with 4 sensor ports

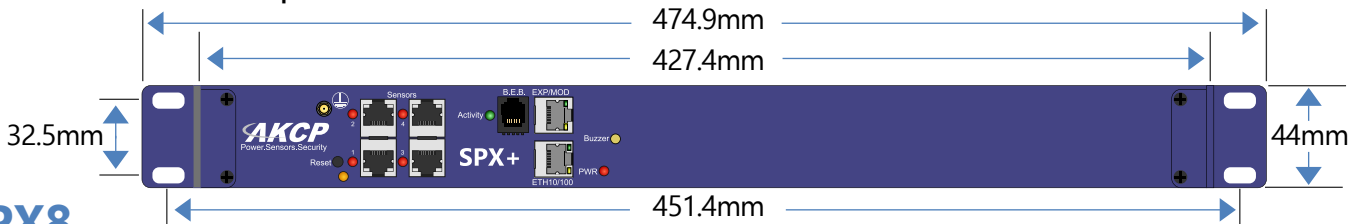

SPX8

SPX with 8 sensor ports

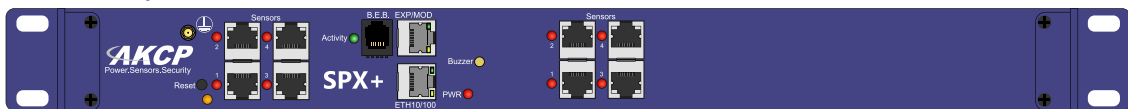

SPX4-X10

SPX with 4 sensor ports and 10 Dry Contacts

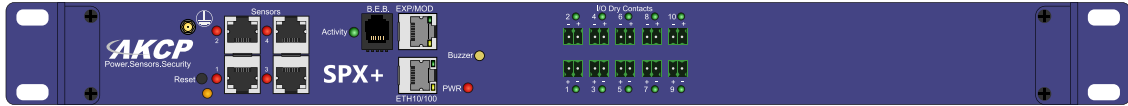

SPX8-X20

SPX with 8 sensor ports and 20 Dry Contacts

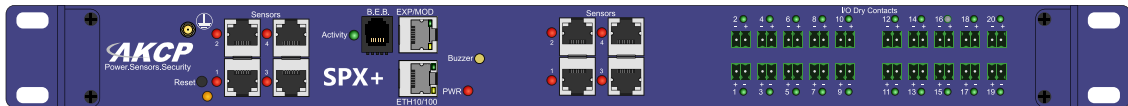

SPX8-60

SPX with 8 sensor ports and 60 Dry Contacts

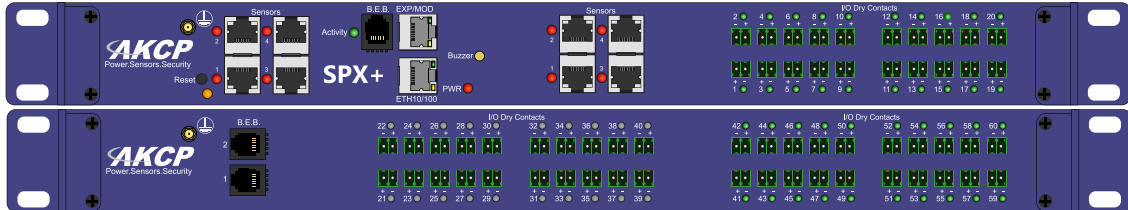

TOP VIEW

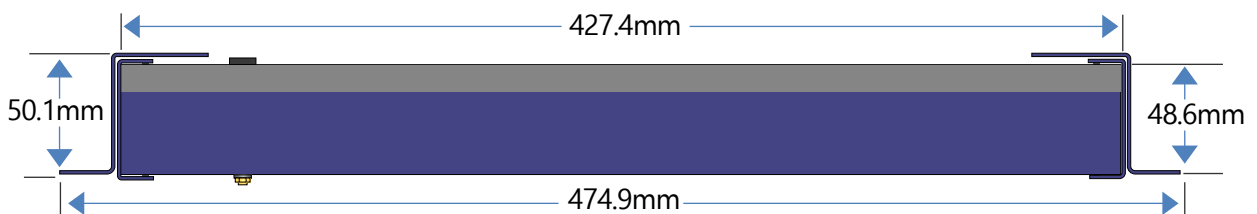

SPX+ Technical Drawing

SPX+ Standard Configurations

SPXB4

SPX BEB with 4 sensor ports

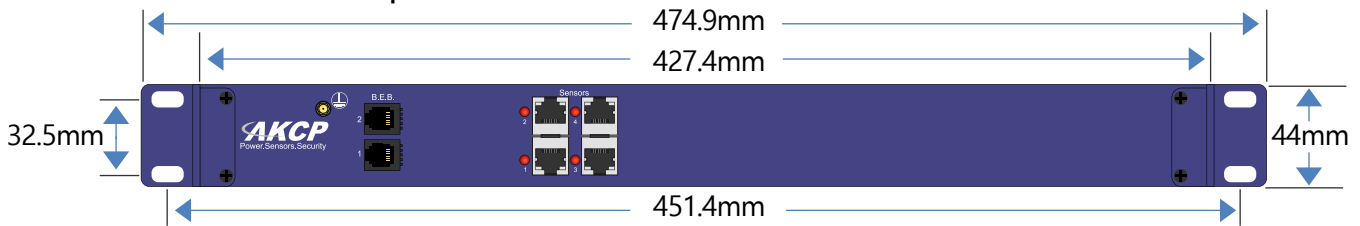

SPXB-X20

SPX BEB with 20 Dry Contacts



SPXB8-X20

SPX BEB with 8 sensor ports and 20 Dry Contacts

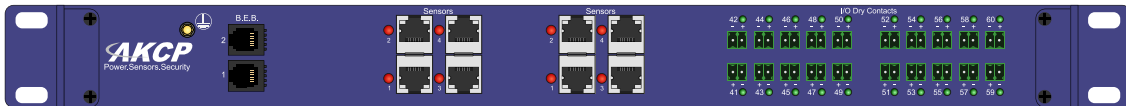

SPXB16

SPX BEB with 16 sensor ports

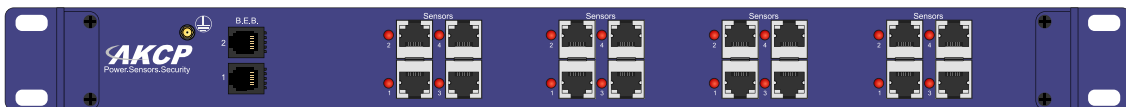

SPXB-X40

SPX BEB with 40 Dry Contacts



TOP VIEW

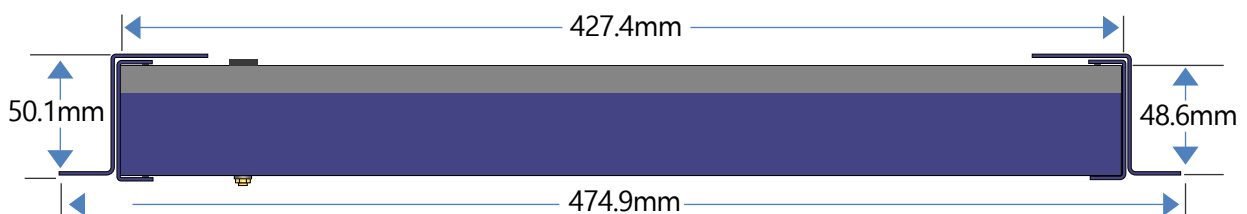

SPX+ Technical Drawing

SPX8-X60

SPX8-X60 is a 2U device, comprised of an SPX+ with BEB unit. This can be mounted in 2 separate U's, or back to back in the same U as illustrated below.

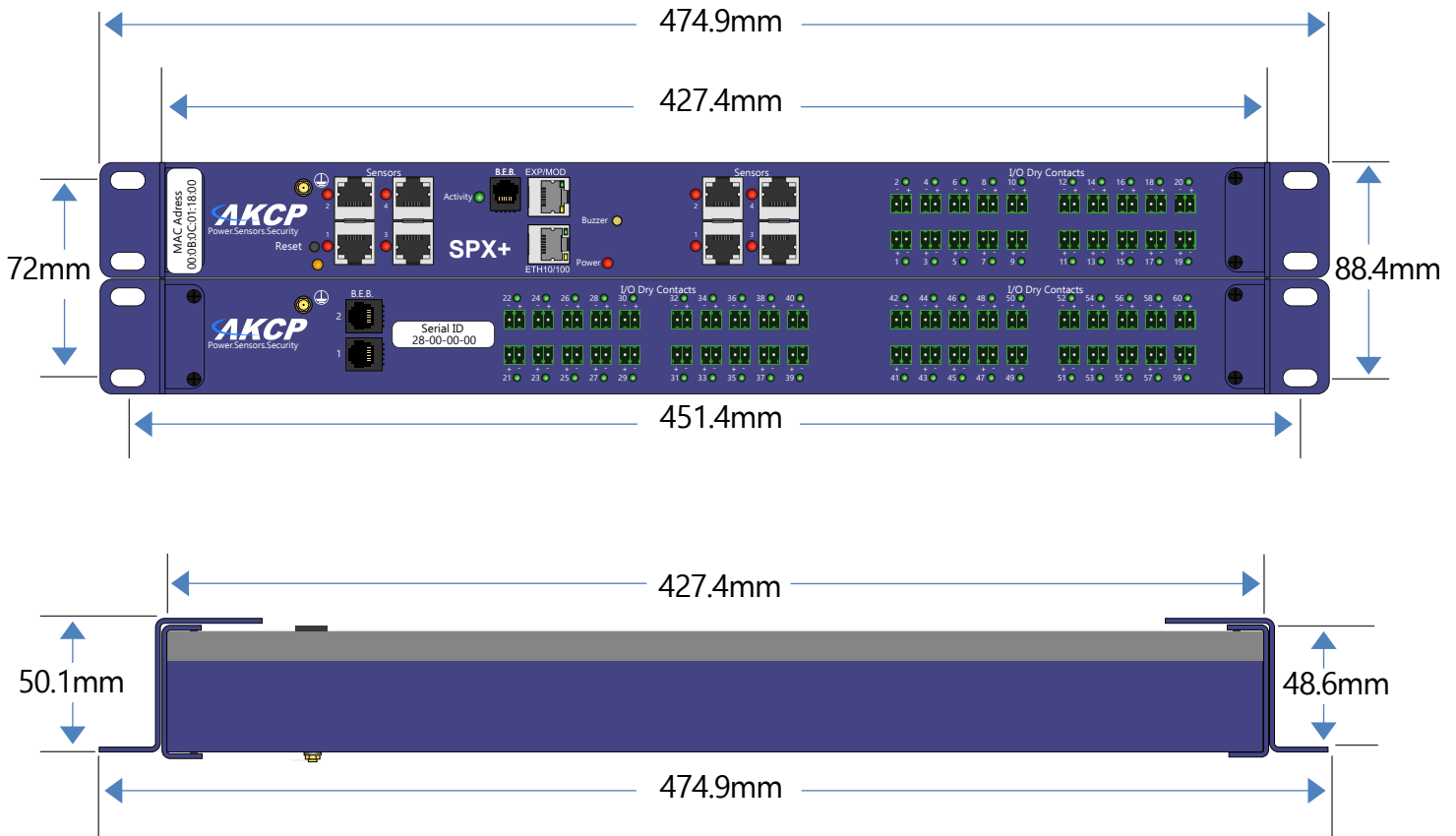

SPX+ Technical Drawing

0U SPX+ with 60x dry contacts
(configured as input only, I/O or opto isolated)

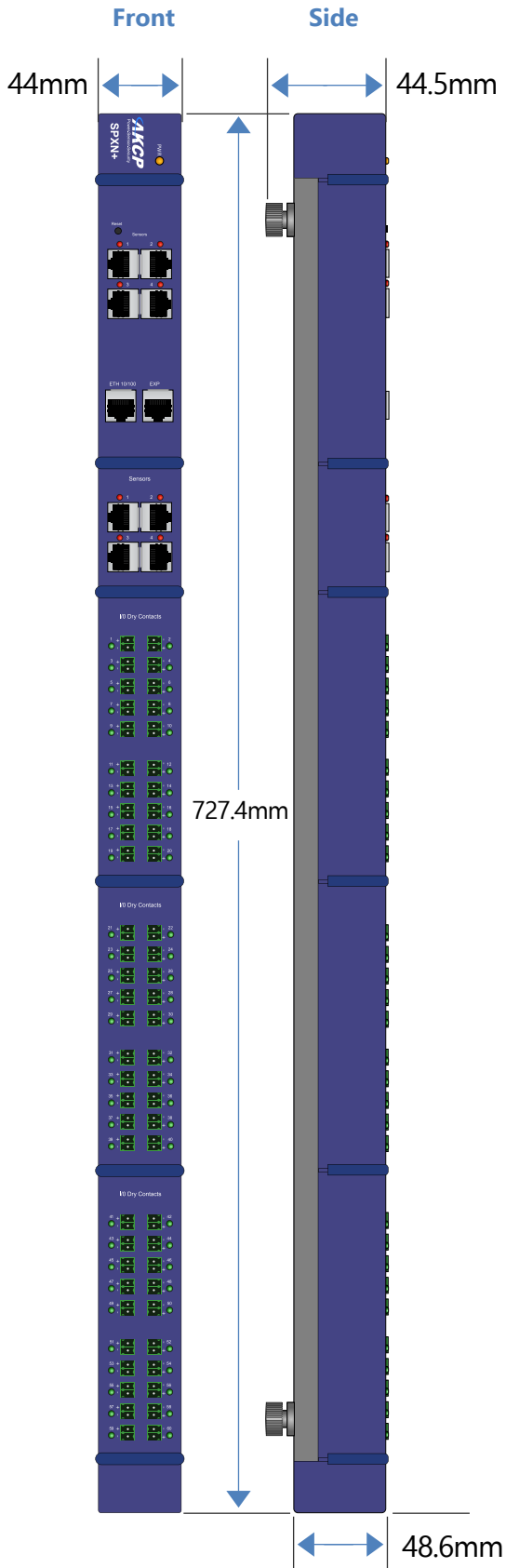

0U SPX+ with 12x sensor ports and 30x dry contacts
(configured as input only, I/O or opto isolated)

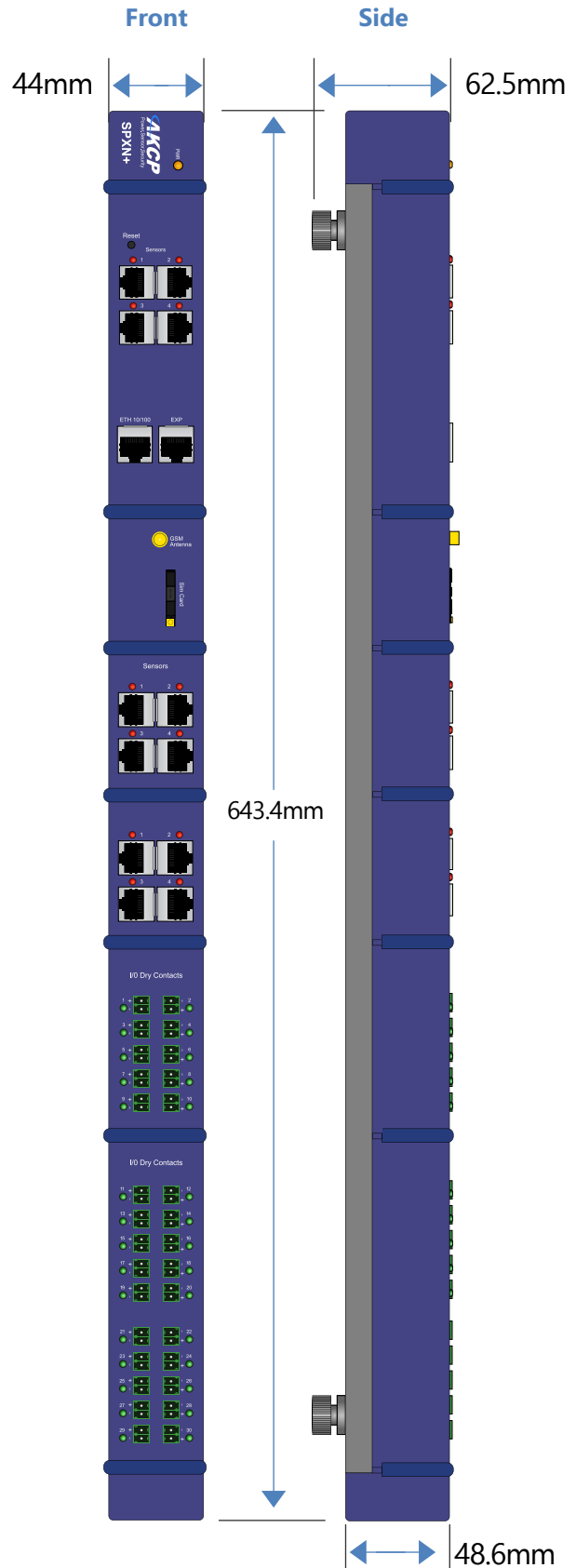

SPX+ Technical Drawing

0U SPX+ with DIN rail mounting.

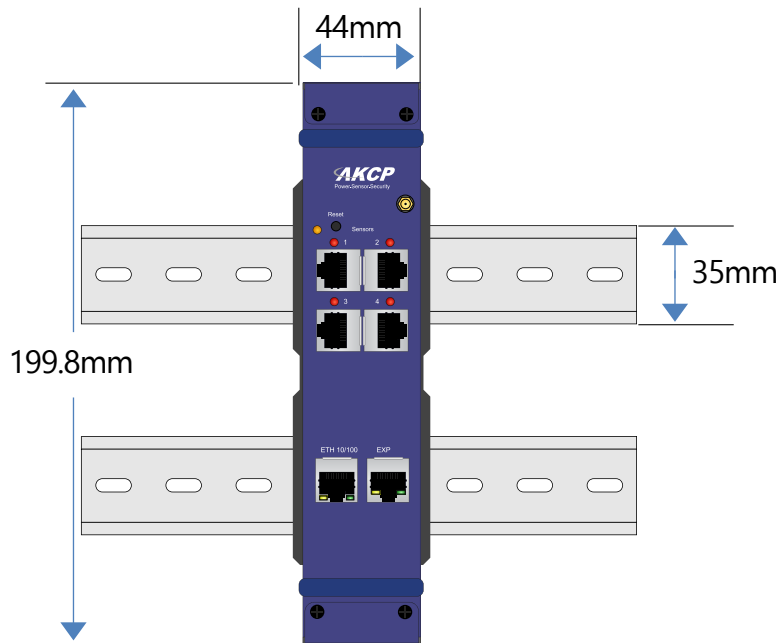

0U SPX+ with internal modem & DIN rail mounting

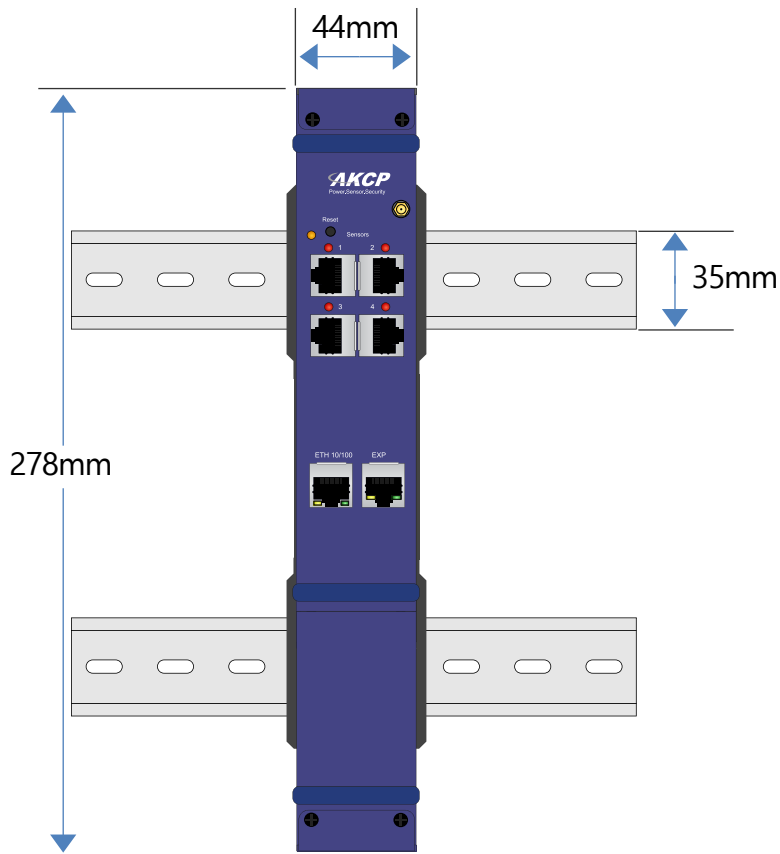

External UART Modem (EM4G)

External Modem for SPXN and SP2+

The SPXN has a dedicated port for connecting an external modem. Ideal for customers who require cellular communications as either primary or backup connection. SMS, e-mail alerts and voice calls* as well as access to the web UI or communications via VPN to AKCPro Server. An optional GPS antenna can be added for mobile asset tracking and monitoring or automatic geo locating static sites on maps in AKCPro Server.



EM4G - Technical Specification

Frequencies	<ul style="list-style-type: none"> • LTE-TDD B34/B38/B39 /B40/B41 • LTE-FDD B1/B2/B3/B5/B7/B8// B12/B13/B18/B19/B20/B25/B26/B28/B66 • UMTS/HSPA+ B1/B2/B4/B5/B6/B8/B19 • GSM/GPRS/EDGE \850/900/1800/1900 MHz
Category	CAT1
Data Transmission	<p>HSPA+: up to 5.76 Mbps(UL), 42 Mbps(DL)</p> <p>LTE Category 1: up to 5 Mbps (UL), 10 Mbps (DL)</p>
Transmitting Power	<p>WCDMA: Class 3 (0.25W)</p> <p>LTE: Class 3 (0.25W)</p>
Features	<p>SMS</p> <p>Telephone Call with Text to Speech via 3rd party e-mail to phone gateway</p> <p>Internet (PPP) : email, VPN, cloud</p> <p>Optional GPS *</p> <p>+ GNSS: GPS/GLONASS/Beidou/Galileo</p> <p>+ GPS active antenna provided</p>
SIM card	<p>Standard SIM card size</p> <p>Support SAT class 3, GSM 11.14 Release 98</p>
Antenna	3m External Antenna
Components	Manufactured using highly integrated, low power surface mount technology to ensure long term reliability.
Operating Environment	<p>Temperature : Min. -20° C – Max.70° C</p> <p>Humidity: Min. 20% – Max. 80% (Non-Condensing)</p>
Certification	<ul style="list-style-type: none"> • CE • RCM • FCC • IC • CCC <p>US Version :</p> <ul style="list-style-type: none"> • TELEC • PTCRB • JA TE • RoHS • REACH

A - Technical Drawing

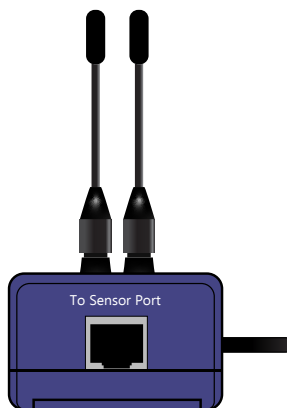
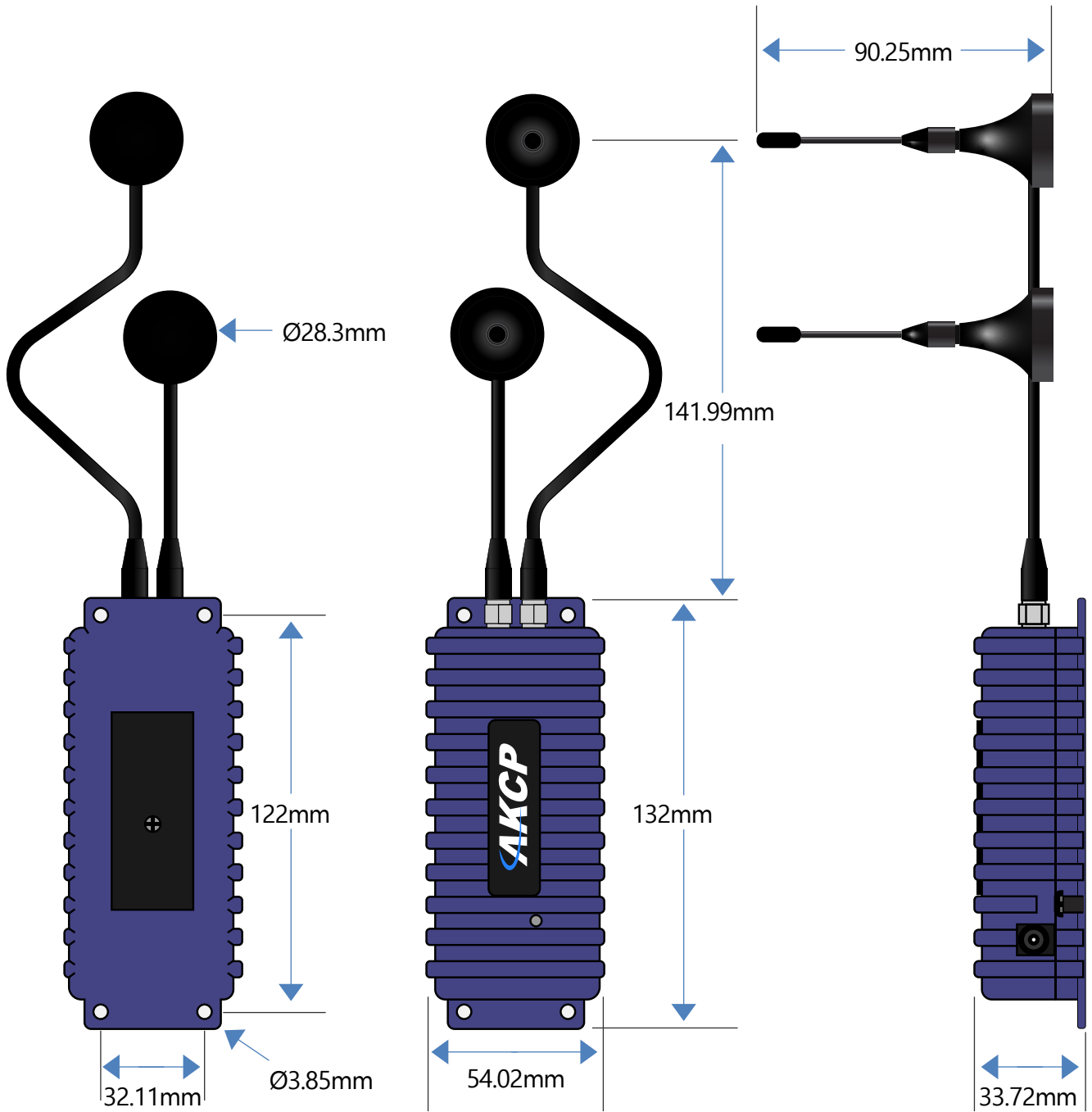

securityProbe Series

Versatile Monitoring device

securityProbe series is our high end, versatile monitoring platform. Includes 80 virtual sensors such as SNMP get, Ping, SNMP Trap receivers. Run custom Bash scripts to expand further it's capabilities.

Options include internal 4G cellular data modems, analog or digital USB cameras, and 40-60VDC internal power supplies

	Name	Code	Description
	securityProbe5E	SEC5ES SEC5ESV SEC5ESVA	8 port sensor device 8 port sensor device with digital video inputs 8 port sensor device with analog video inputs
	securityProbe5E X20	SEC5ES-X20 SEC5ESV-X20 SEC5ESVA-X20	8 port sensor device with 20x dry contacts 8 sensor ports with 20x dry contacts & digital video inputs 8 sensor ports with 20x dry contacts & analog video inputs
	securityProbe5E X60	SEC5ES-X60 SEC5ESV-X60 SEC5ESVA-X60	8 port sensor device with 60x dry contacts 8 sensor ports with 60x dry contacts & digital video inputs 8 sensor ports with 60x dry contacts & analog video inputs
	Internal 4G Modem (EU/US Frequencies)	SECM4E SECM4A	4G EU Internal Modem 4G US Internal Modem
	Cameras	HD-DC HD-PTDC UMC-PAL UMC-NTSC PTDC-PAL PTDC-NTSC	High Definition USB Camera High Definition USB Pan Tilt Camera Analog PAL Camera Analog NTSC Camera Analog PAL Pan Tilt Camera Analog NTSC Pan Tilt Camera

securityProbe5E (SEC5ES/V/A)



Advanced monitoring system with video capabilities

securityProbe5E comes in several versions, the 5ES, which has no video function, 5ESV, which has 4x USB digital video inputs, and the 5ESVA which has 4x BNC analog video inputs. Packages are available with cameras included, or connect with existing analog cameras in your facility.

Optional 3G or 4G internal modems can be installed to send SMS alerts directly from the securityProbe device, or for communicating in sites with no wired network available.

BNC video inputs ports found on the 5ESVA device On the 5ESV these are substituted for USB digital video inputs

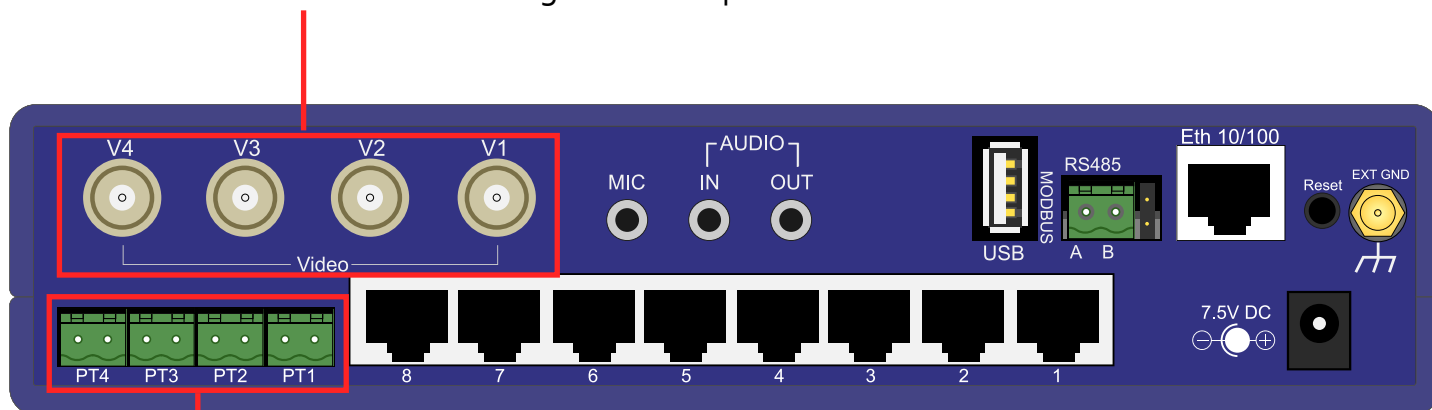

PTZ controller ports, connect with Pelco.D standard PTZ cameras to control the Pan, Tilt and Zoom from the securityProbe web interface

SEC5ES/V/A - Dual Power Input

SEC5ES can be powered via dual AC or DC inputs, providing redundancy for powering the device. The 40-60VDC external power supplies feature dual DC inputs with a single 9VDC output for powering the SEC5ES.

Ideal for telecoms applications where DC power comes straight into the cabinets. Or in a data center with dual PDU's. Utilize 2x 12VDC power adapters, one on each AC power source, connect them to the DCW075 with the output to the DC jack on the SEC5ES.

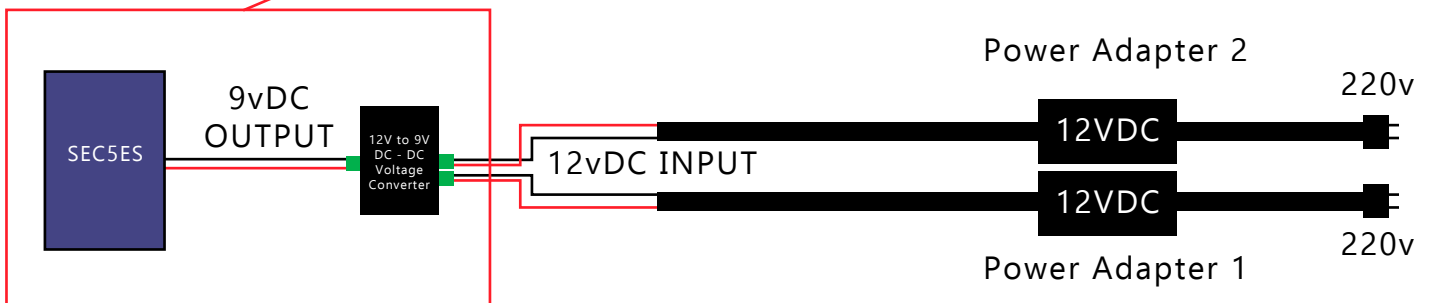
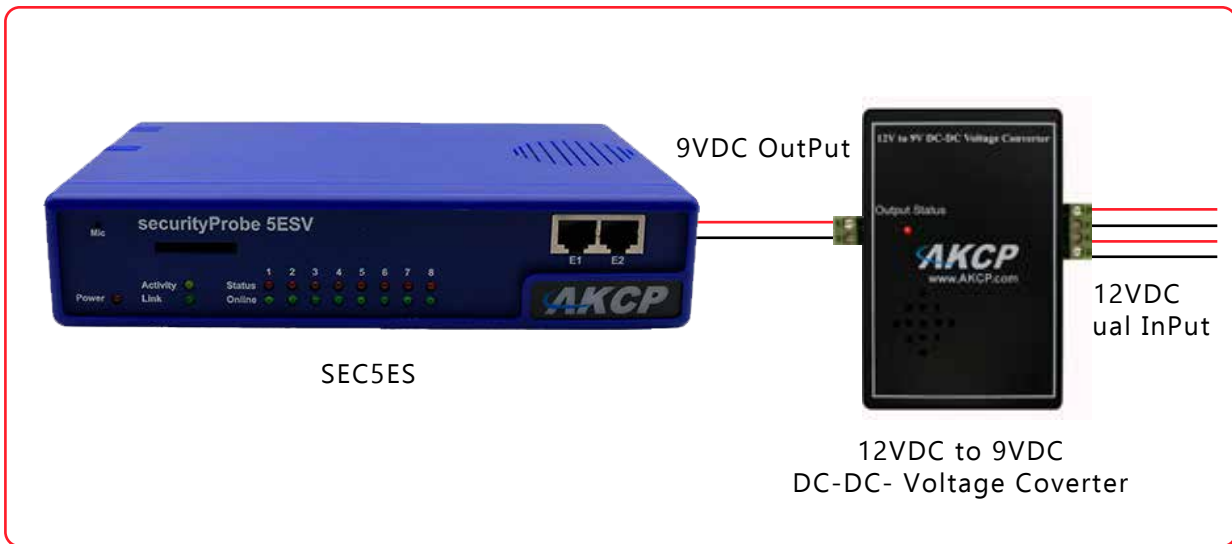

SEC5ES/V/A - Technical Specification

Dimension	Size 8.5 x 5.43 x 1.80 Weight 1 Kg
Expansion Port	2x RJ-45 Expansion Ports 115.2K BPS Data Transfer Rate Simultaneous functionality between Expansion Ports & RS485 port threshold status
Mounting	1U Rack Mount Standard Rack mount brackets included Compatible with AKCP's DIN and rack mount trays
Power	External 7.0 – 9 VDC 3A Power Adapter Input Voltage and Current ratings : 100V~240V - 1A Optional - DCW : external +/- 40~60V DC input
Power Consumption	Typical 5.025 Watt, 0.67A
Status Indication	LED indication for power LED for network connectivity LED for sensor online and threshold status
Components	Manufactured using highly integrated, low power surface mount technology to ensure long term reliability. CPU: AKCP i.MX25 Processor 128 MB On-Board NAND Flash HC SD Memory Slot on-board (up to 16GB)
Operating Environment	Temp : Min. -35° C – Max. +55° C Humidity : Min. 20% – Max. 80% (Non-Condensing)
MTBF	400,000 Hours
Connectivity	Ethernet 10/100 Mbps Optional Internal 3G/4G modem
Inputs	8x RJ-45 Sensor Ports 2x RJ-45 Expansion Ports 1x USB 2.0 Modem Port Audio In (Analog) 2.5 jack Internal Microphone RS485, 2 Pin Terminal box, (used for Modbus)
Outputs	Configurable output signals (0VDC/5VDC) on any of the 8 RJ-45 sensor ports Internal Speaker Out Ext. Speaker Out, 2.5" jack (Analog) Mic Out, 2.5 jack (Analog) (For modem application)
Expansion Boards	8 Port Intelligent Sensors Module (E-Sensor8) 16 Port Dry Contacts Module (E-opto16) (Maximum of 500 Sensors) Cabinet Control Unit (DCU) (Up to 25 Per Chain) Extendable up to 1,000 Feet or 300 meters Expansion modules are daisy chainable
Video - Analog	4x Analog Video BNC input, powered externally * resolution 320x240 or 640x480 * type : NTSC or PAL 4x PTDC controller ports
Video- HD Digital	4x AKCP High Definition Digital camera USB input resolution 320x240 or 640x480 4x PTDC controller ports

SEC5E - Technical Drawing

Technical drawing illustrates SEC5ESVA, dimensions of 5ES and 5ESV are the same

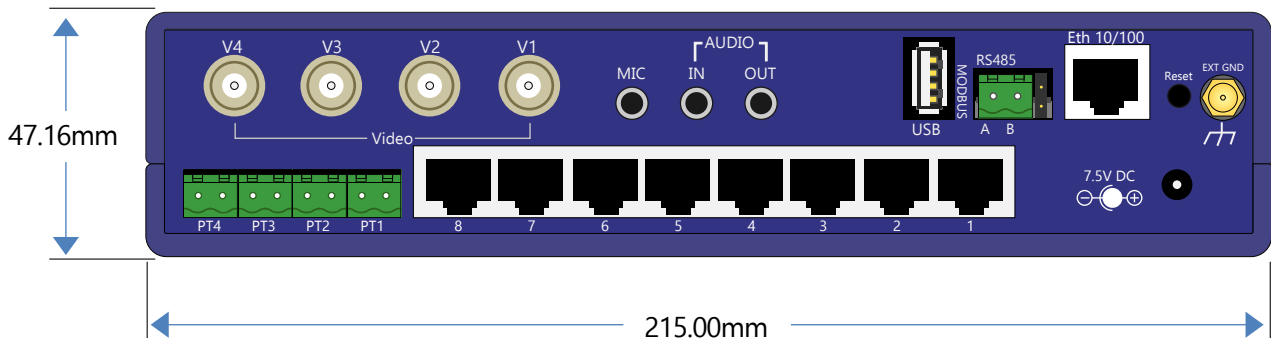
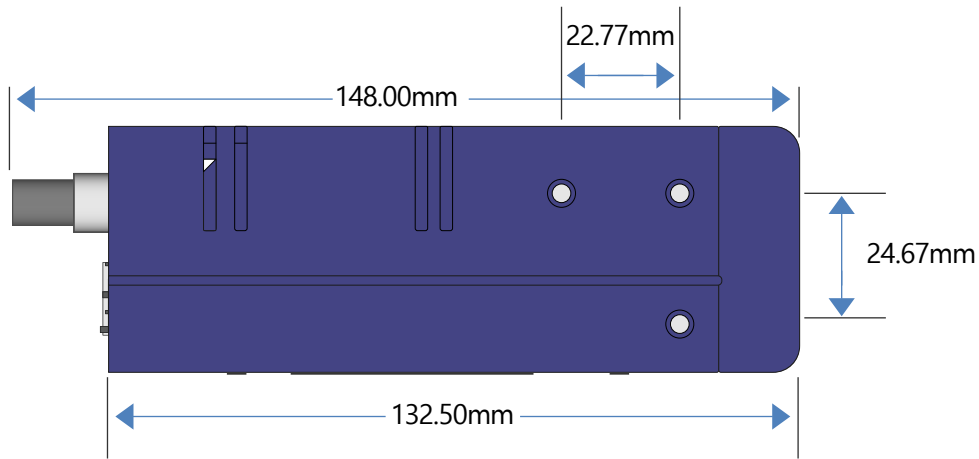
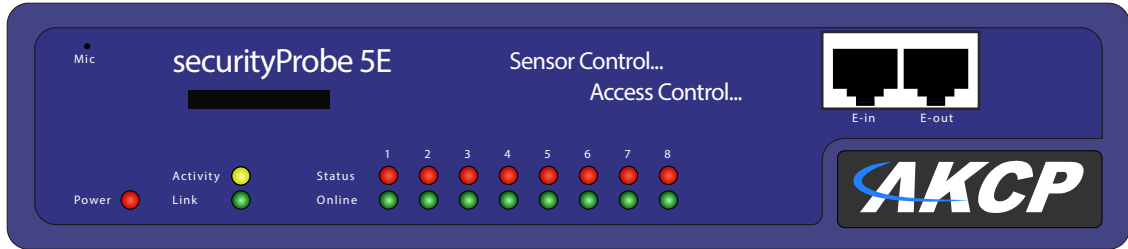

securityProbe with 1U rackmount brackets

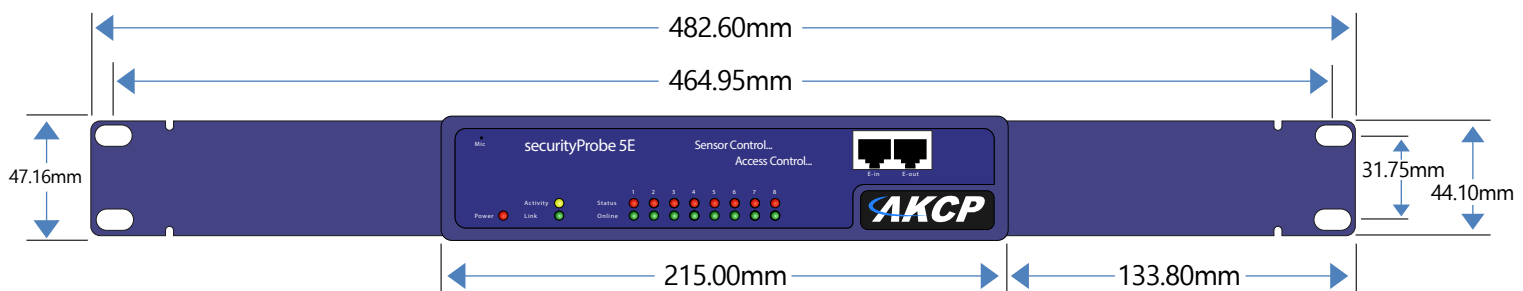

securityProbe5E-X20 (SEC5ES/V/A-X20)



A securityProbe with 20 dry contact inputs

Based on the basic securityProbe5E the X20 comes with all the same options, no video, with analog video or digital video inputs, plus 20 dry contact digital inputs. These can be set to opto isolated mode with a jumper for instances where there is a chance of over voltage.

Optional 3G and 4F internal modems can be installed to send SMS alerts directly from the securityProbe device, or for communicating in sites with no wired network available.

Based on the basic securityProbe5E the X20 comes with all the same options, no video, with analog video or digital video inputs, plus 20 dry contact digital inputs. These can be set to opto isolated mode with a jumper for instances where there is a chance of over voltage.

Optional 3G and 4G internal modems can be installed to send SMS alerts directly from the securityProbe device, or for communicating in sites with no wired network available.

Analog BNC video inputs (5ESVA only).
5ESV comes with USB digital video inputs

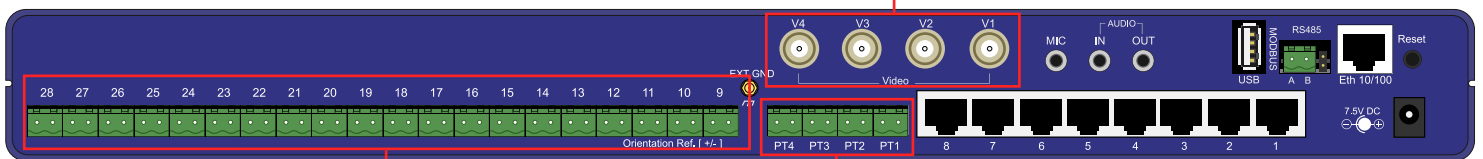

20x dry contacts with jumper settings for opto isolation

4x PTZ controller ports for Pelco.d compatible PTZ cameras (5ESV and 5ESVA only)

SEC5ES/V/A-X20 - Technical Specification

Dimension	Size : 17.08" x 5.43" x 1.80" Weight : 2.6 Kg
Expansion Port	2x RJ-45 Expansion Ports 115.2K BPS Data Transfer Rate Simultaneous functionality between Expansion Ports & RS485 port threshold status
Mounting	1U Rack Mount Standard Rack mount brackets included Compatible with AKCP's DIN and rack mount trays
Power	External 7.0 – 9 VDC 3A Power Adapter Input Voltage and Current ratings : 100V~240V - 1A Optional - DCW : external +/- 40~60V DC input
Power Consumption	Typical 6.150 Watt, 0.82A
Status Indication	LED indication for power LED for network connectivity LED for sensor online and threshold status LED for dry contact online and status
Components	Manufactured using highly integrated, low power surface mount technology to ensure long term reliability. CPU: AKCP i.MX25 Processor 128 MB On-Board NAND Flash HC SD Memory Slot on-board (up to 16GB)
Operating Environment	Temp : Min. -35° C – Max. +55° C Humidity : Min. 20% – Max. 80% (Non-Condensing)
MTBF	400,000 Hours
Connectivity	Ethernet 10/100 Mbps Optional Internal 3G/4G modem
Inputs	8x RJ-45 Sensor Ports 2x RJ-45 Expansion Ports 20x 2 Wire dry contacts (Input only up to 5VDC and up to 40VDC in opto isolated mode using internal jumper setting) 1x USB 2.0 Modem Port Audio In (Analog) 2.5 jack Internal Microphone RS485, 2 Pin Terminal box, (used for Modbus)
Outputs	Configurable output signals (0VDC/5VDC) on any of the 8 RJ-45 sensor ports Internal Speaker Out Ext. Speaker Out, 2.5" jack (Analog) Mic Out, 2.5 jack (Analog) (For modem application)
Expansion Boards	8 Port Intelligent Sensors Module (E-Sensor8) 16 Port Dry Contacts Module (E-opto16) (Maximum of 500 Sensors) Cabinet Control Unit (DCU) (Up to 25 Per Chain) Extendable up to 1,000 Feet or 300 meters Expansion modules are daisy chainable
Video - Analog	4x Analog Video BNC input, powered externally * resolution 320x240 or 640x480 * type : NTSC or PAL 4x PTDC controller ports
Video- HD Digital	4x AKCP High Definition Digital camera USB input resolution 320x240 or 640x480 4x PTDC controller ports

SEC5ES/V/A-X20 - Technical Drawing

Technical drawing illustrates SEC5ESVA-X20, dimensions of 5ES and 5ESV are the same

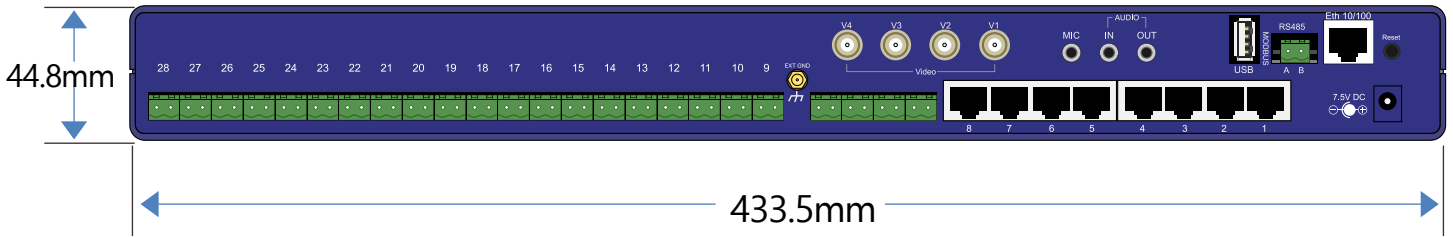
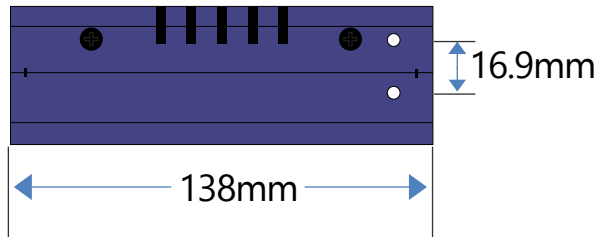

securityProbe5E-X20 with 1U rackmount brackets

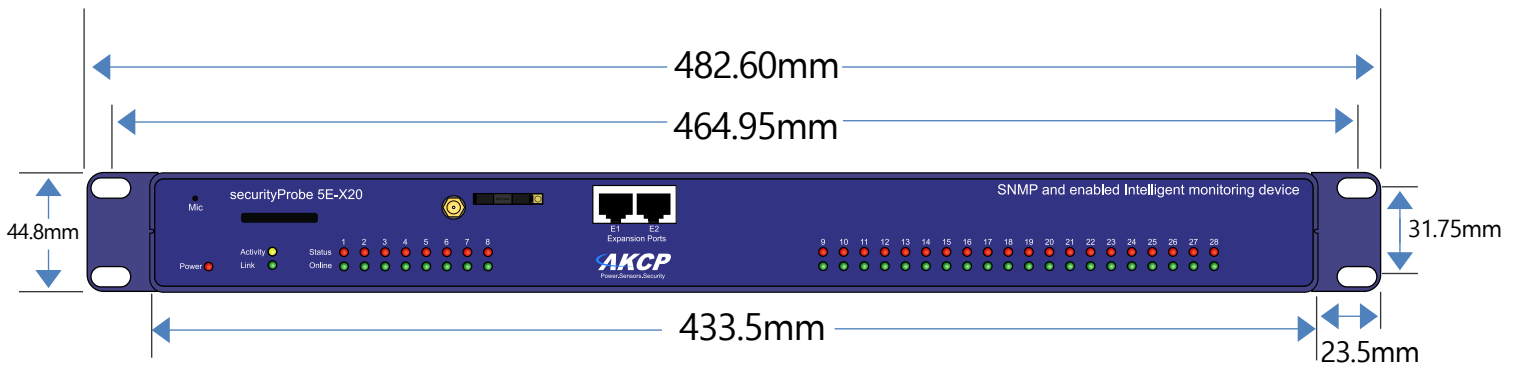

securityProbe5E-X60 (SEC5ES/V/A-X60)



A securityProbe with 60 dry contact inputs.

Based on the basic securityProbe5E the X60 comes with all the same options, no video, with analog video or digital video inputs, plus 60 dry contact digital inputs. These can be set to opto isolated mode with a jumper for instances where there is a chance of over voltage.

Optional 3G and 4G internal modems can be installed to send SMS alerts directly from the securityProbe device, or for communicating in sites with no wired network available.

Based on the basic securityProbe5E the X20 comes with all the same options, no video, with analog video or digital video inputs, plus 20 dry contact digital inputs. These can be set to opto isolated mode with a jumper for instances where there is a chance of over voltage.

Analog BNC video inputs (5ESVA only)
5ESV comes with USB digital video inputs

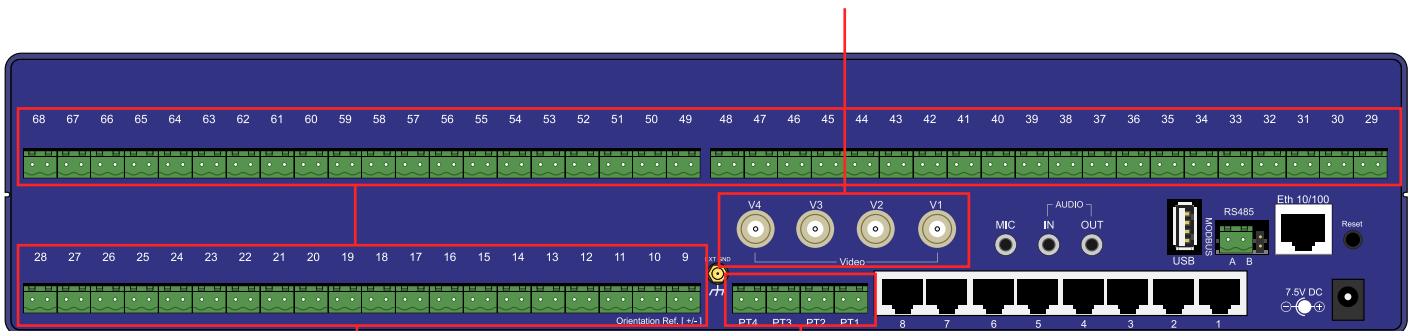

60x dry contacts with jumper settings for opto isolation

4x PTZ controller ports for Pelco.d compatible PTZ Cameras (5ESV and 5ESVA only)

SEC5ES/V/A-X20 - Technical Specification

Dimension	Size : 18" x 5" x 3.45" Weight : 3.1 Kg
Expansion Port	2x RJ-45 Expansion Ports 115.2K BPS Data Transfer Rate Simultaneous functionality between Expansion Ports & RS485 port threshold status
Mounting	2U Rack Mount Standard Rack mount brackets included Compatible with AKCP's DIN and rack mount trays
Power	External 7.0 – 9 VDC 3A Power Adapter Input Voltage and Current ratings : 100V~240V - 1A Optional - DCW : external +/- 40~60V DC input
Power Consumption	Typical 6.150 Watt, 0.82A
Status Indication	LED indication for power LED for network connectivity LED for sensor online and threshold status LED for dry contact online and status
Components	Manufactured using highly integrated, low power surface mount technology to ensure long term reliability. CPU: AKCP i.MX25 Processor 128 MB On-Board NAND Flash HC SD Memory Slot on-board (up to 16GB)
Operating Environment	Temp : Min. -35° C – Max. +55° C Humidity : Min. 20% – Max. 80% (Non-Condensing)
MTBF	400,000 Hours
Connectivity	Ethernet 10/100 Mbps Optional Internal 3G/4G modem
Inputs	8x RJ-45 Sensor Ports 2x RJ-45 Expansion Ports 20x 2 Wire dry contacts (Input only up to 5VDC and up to 40VDC in opto isolated mode using internal jumper setting) 1x USB 2.0 Modem Port Audio In (Analog) 2.5 jack Internal Microphone RS485, 2 Pin Terminal box, (used for Modbus)
Outputs	Configurable output signals (0VDC/5VDC) on any of the 8 RJ-45 sensor ports Internal Speaker Out Ext. Speaker Out, 2.5" jack (Analog) Mic Out, 2.5 jack (Analog) (For modem application)
Expansion Boards	8 Port Intelligent Sensors Module (E-Sensor8) 16 Port Dry Contacts Module (E-opto16) (Maximum of 500 Sensors) Cabinet Control Unit (DCU) (Up to 25 Per Chain) Extendable up to 1,000 Feet or 300 meters Expansion modules are daisy chainable
Video - Analog	4x Analog Video BNC input, powered externally * resolution 320x240 or 640x480 * type : NTSC or PAL 4x PTDC controller ports
Video- HD Digital	4x AKCP High Definition Digital camera USB input resolution 320x240 or 640x480 4x PTDC controller ports

SEC5ES/V/A-X60 - Technical Drawing

Technical drawing illustrates SEC5ESVA-X60, dimensions of 5ES and 5ESV are the same

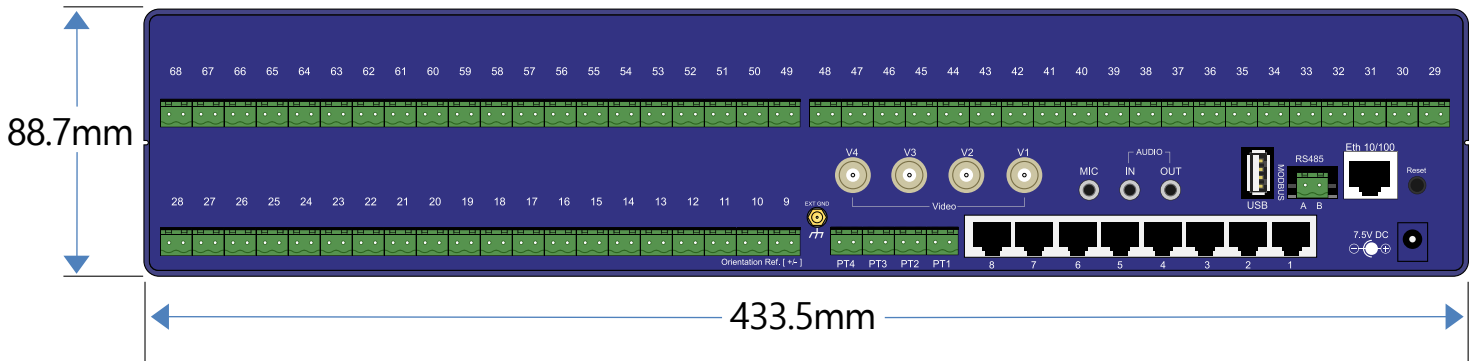
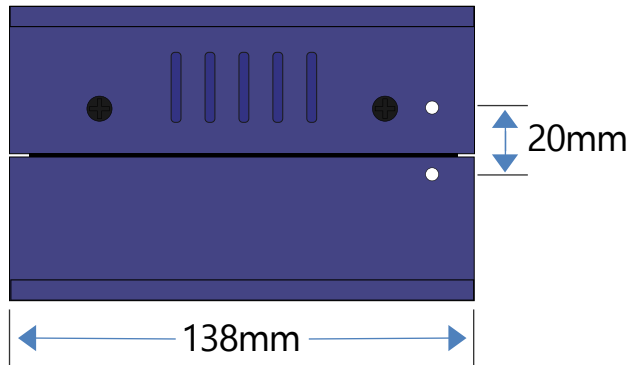
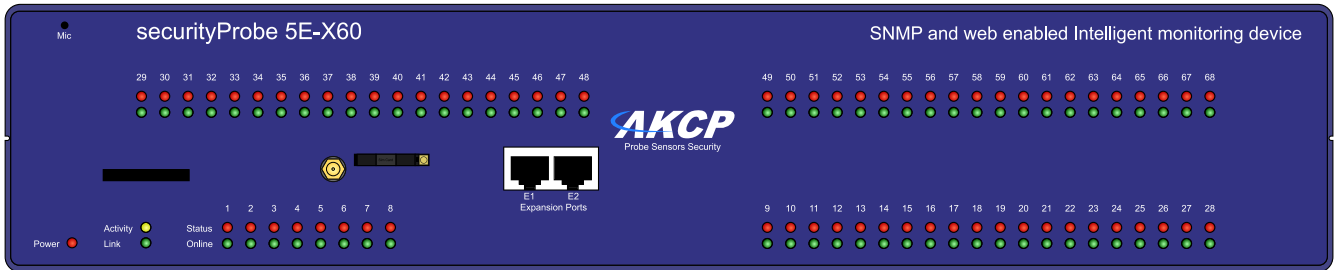

securityProbe5E-X60 with 1U rackmount brackets

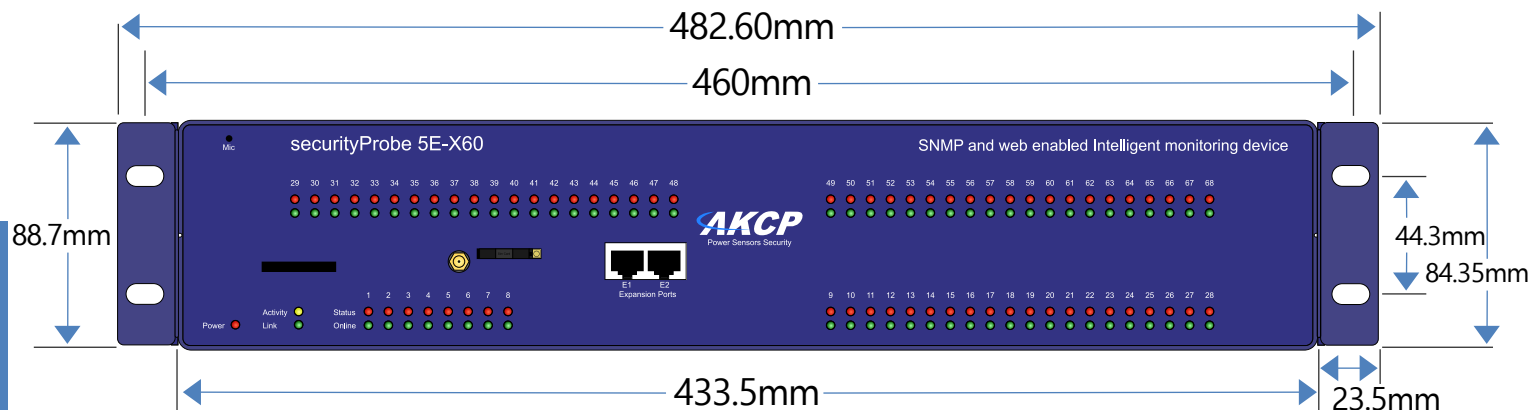

securityProbe5E-X60 (SEC5ES/V/A-X60)

Analog and Digital Cameras for your securityProbe

Connect up to 4x analog (5ESVA models) or digital cameras (5ESV). Pan and tilt camera option gives remote control of the camera position and automatically point to pre-set positions on sensor events.

Synchronize sensor events with camera footage, taking snapshots or video when an event happens, sending it via E-mail or MMS, giving you a visual reference to the situation at your monitored location.

 UMC	<p><u>Support</u></p> <p>securityProbe 5ESVA securityProbe 5ESVA-X20 securityProbe 5ESVA-X60</p>
 PTDC	<p><u>Support</u></p> <p>securityProbe 5ESVA securityProbe 5ESVA-X20 securityProbe 5ESVA-X60</p>
 HD-DC	<p><u>Support</u></p> <p>securityProbe 5ESV securityProbe 5ESV-X20 securityProbe 5ESV-X60</p>
 HD-PTDC	<p><u>Support</u></p> <p>securityProbe 5ESV securityProbe 5ESV-X20 securityProbe 5ESV-X60</p>

Analog and Digital Cameras Technical Specification

Camera Control (Pan & Tilt cameras only)	Remote pan and tilt (remote 330deg pan, 80deg tilt) Control of camera motor via web~interface (administrator only)
	Camera control port PT1 -4, Pelco D RS485, 2 pins Terminal 11 all box Precision, custom designed stepper motor
	Image Sensor
CCD	High quality Sony CCD Light sensitivity of .5 lux at f 1.2 1/3" interline CCD Auto White Balance 640 pixels per line, with 625 per frame (interlaced)
Electronic Iris	1/50 - 1/100,000 (PAL); 1/60 - 1/100,000 (NTSC)
Picture Elements	640 (H) x 480 (V)
S/N Ratio	45dB or more (AGC on)
	Connections
Video	BNC (Analog, UMC-PAUNTS and PTDC-PAUNTS) USB (Digital, HD-DC and HD-PTDC)
Power	2.5mm Male plug
	Optic
Lens Type	Fixed
Focal Length	3.6mm
Viewing Angle	92 deg
	Physical Environment
Weight	0.8 kg (PTDC) 0.3 kg (HD and UMC)
Power	9VDC, external (PTDC and UMC versions) 5VDC powered by security Probe (HD-DC only)
Power consumption	2.16W
Operating temp. range	0 - 40 °C
Operating humidity range	10 - 80 % RH, non-condensing

UMC / HD-DC - Technical Drawing

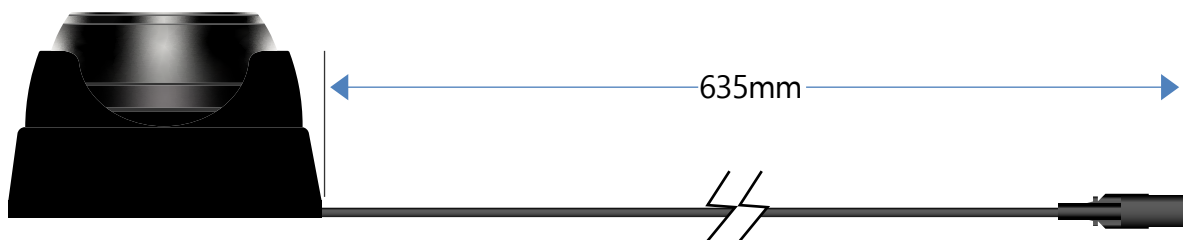
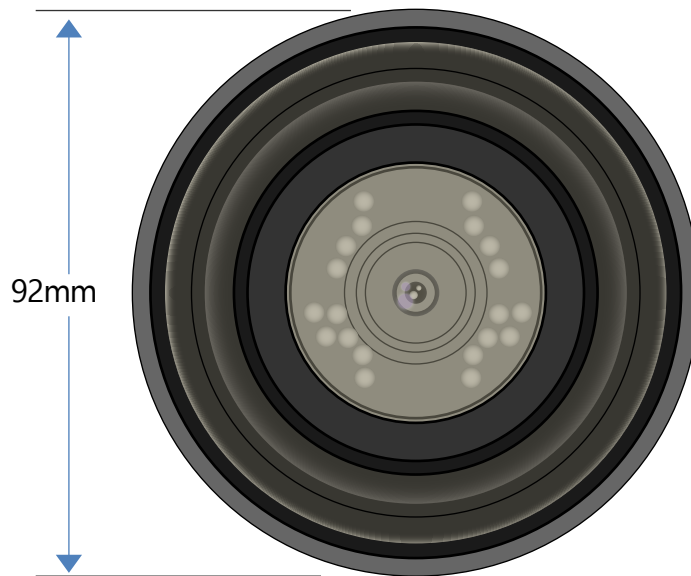
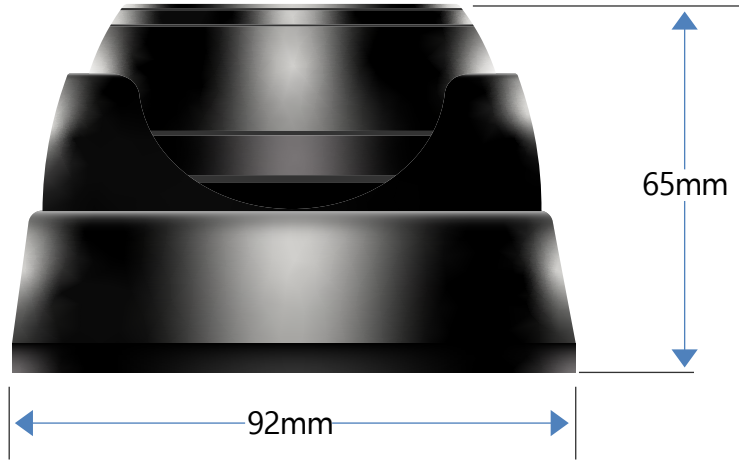

PTDC / Hd-PTDC - Technical Drawing

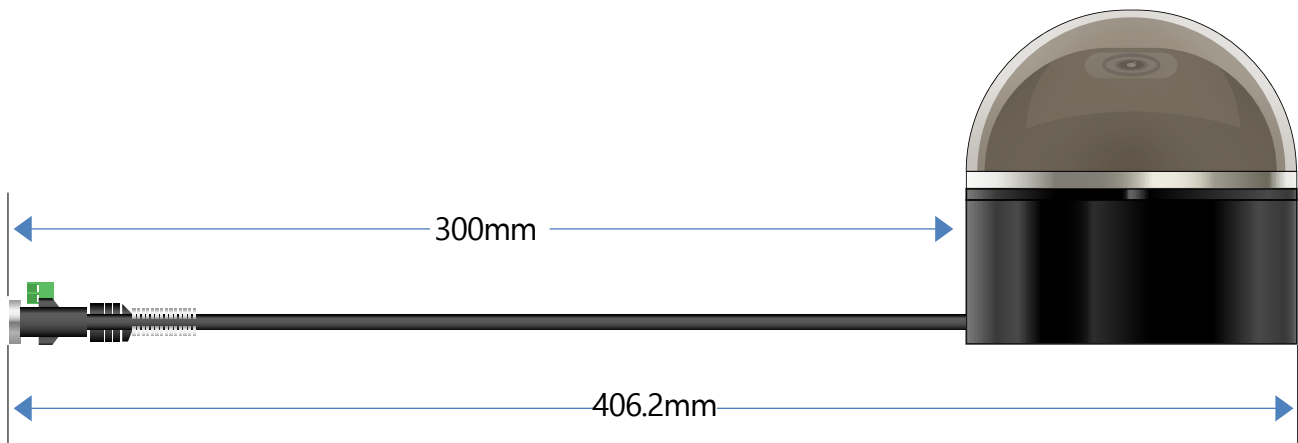
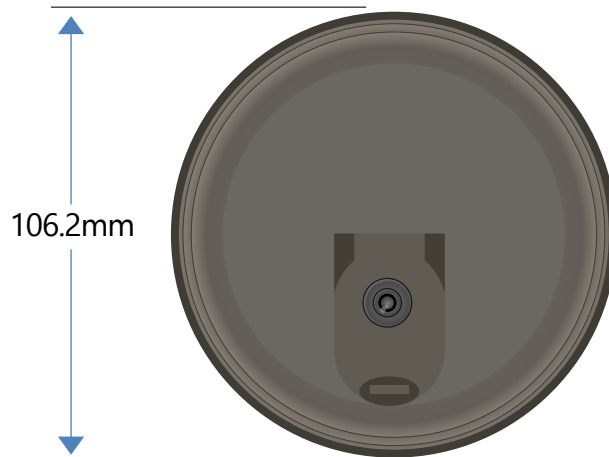
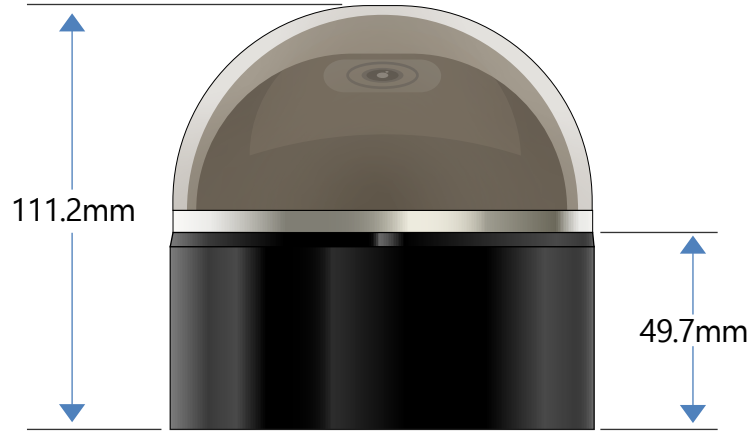

SEC Cellular Data Modem

Internal Modem for securityProbes

if your securityProbe is installed at a remote site with no wired internet connection available, or you wish to have a backup means of communication should your internet network be unavailable, then choose the option to install a 3G or 4G internal modem. An internal cellular data modem also allows you to send SMS and MMS alerts directly from the securityProbe device itself, notifying you of a sensors critical status.

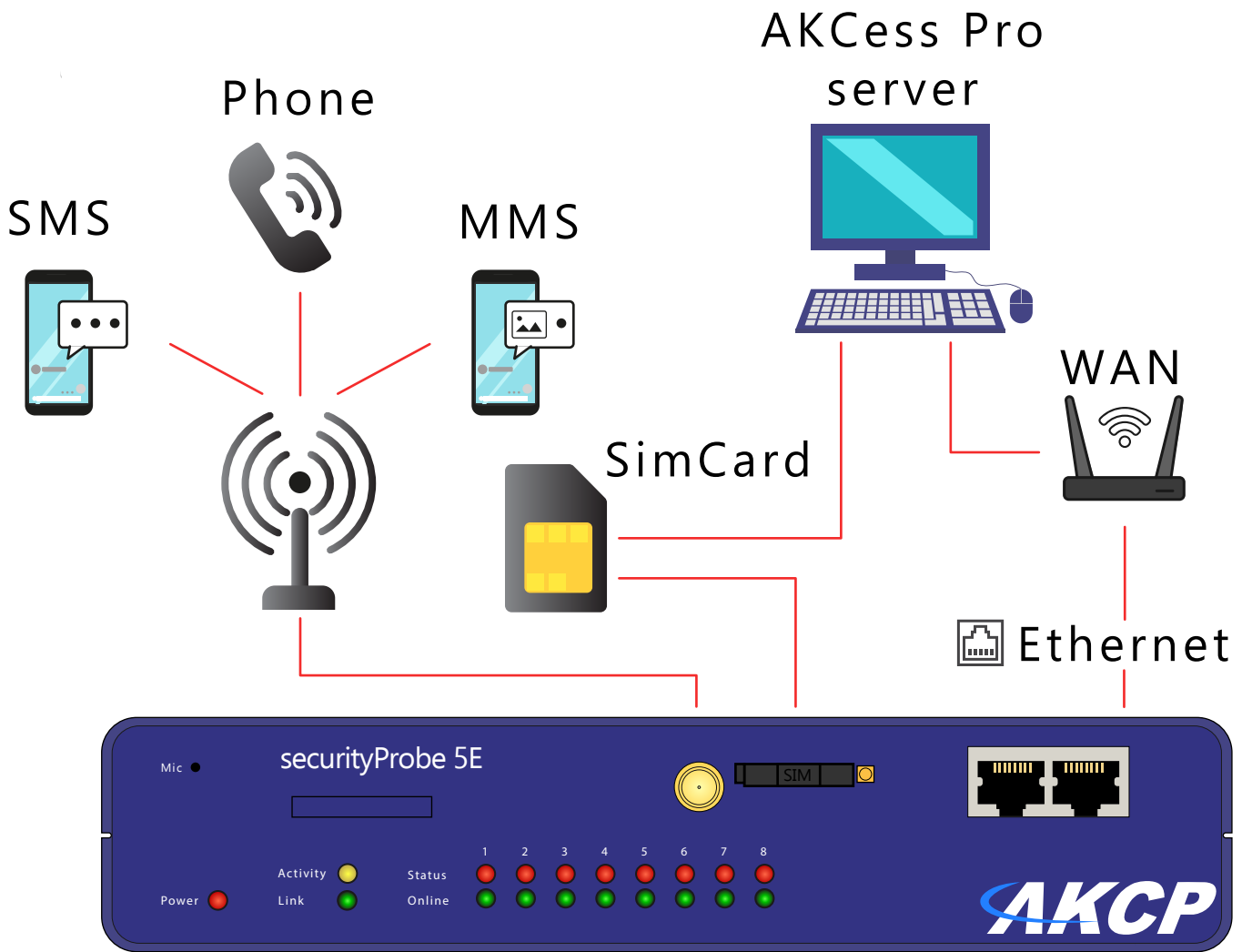

SEC Cellular Data Modem (4G) - Technical Specification

Frequencies	<p>EU model :</p> <p>Dual-Band UMTS/HSDPA/HSPA+ : Band 1 & 5</p> <p>LTE-FDD : B1, B3, B5, B7, B8, B28</p> <p>US model :</p> <p>Dual-Band UMTS/HSDPA/HSPA+ : Band 2 & 5</p> <p>LTE-FDD : B2, B4, B12</p>
Category	CAT1
Data Transmission	<p>HSPA+: up to 5.76 Mbps(UL), 42 Mbps(DL)</p> <p>LTE Category 1: up to 10 Mbps (DL)</p> <p>LTE Category 1: up to 5 Mbps (UL)</p>
Transmitting Power	<p>WCDMA: Class 3 (0.25W)</p> <p>LTE: Class 3 (0.25W)</p>
Features	<p>SMS</p> <p>Internet (PPP) : email, VPN</p>
SIM card	<p>Standard SIM card size</p> <p>Support SAT class 3, GSM 11.14 Release 98</p>
Antenna	3m External Antenna
Components	Manufactured using highly integrated, low power surface mount technology to ensure long term reliability.
Operating Environment	<p>Temperature : Min. -20° C – Max.70° C</p> <p>Humidity: Min. 20% – Max. 80% (Non-Condensing)</p>
Certification	<p>US Version :</p> <ul style="list-style-type: none"> • FCC • IC • PTCRB • ROHS • REACH <p>EU Version :</p> <ul style="list-style-type: none"> • CE-RED • NCC • ACMA • ROHS • REACH
Carrier Certification	<p>US version :</p> <ul style="list-style-type: none"> • AT&T/Rogers
Important Note	This modem does not support telephone call text to speech

8 Port Sensor Expansion Unit (E-IS8N / E-IS8N-DIN)



Expand your base unit with more sensor ports.

Should you need more sensor ports on your securityProbe or sensorProbeX+, a cost effective way is to add E-Sensor8 expansion units. Up to 1,000ft (300m) cable length can be used between the securityProbe and the E-Sensor8.

Additional expansion units can be daisy chained with up to 1,000ft (300m) between each unit. A maximum of 600 total sensor points can be monitored from a single IP address.

1U Rackmount or DIN rail

The E--Sensor8 is available in a 1U rack mounted version with standard rackmount brackets, or in a short DIN rail mounted version. The product code for this version is E-IS8N-DIN.



E-IS8N / E-IS8N-DIN - Technical Specification

Dimension	427mm (W) x 44mm (H) low profile design
Network Interface	2x RJ-45 Expansion Ports
Mounting	115.2K bps Data Transfer Rate 1U Rack Mount Standard
Power	External 5.5 VDC 3A Power Adapter Input Voltage and Current ratings : 100V~240V - 1A Typical 5.025 Watt, 0.67A
Status Indication	LED indication for power LED for Expansion port connectivity LED for sensor online and threshold status
Components	Manufactured using highly integrated, low power surface mount technology to ensure long term reliability.
Operating Environment	Temp : Min. -35° C – Max. +80° C Humidity : Min. 20% – Max. 80% (Non-Condensing)
MTBF	400,000 Hours
Inputs	8x RJ-45 ports for connecting AKCP sensors 1x RJ-45 expansion module input (E-in)
Outputs	Configurable output signals (0VDC/5VDC) on any of the 8 RJ-45 sensor ports 1 RJ-45 expansion module output (E-out)
E-Modules	<ul style="list-style-type: none"> * Daisy chain multiple E-modules including E-sensor8 and E-opto16 combined * Uses standard RJ-45 connections and CAT5 LAN cable * Maximum extension cable run length: 300 meters (1000 feet) * Compatible with AKCP intelligent sensors. Not compatible with SP+ smart sensors or TMP NIST2/3 * Connect up to 500 AKCP intelligent sensors to one securityProbe5ES * Connect up to 150 AKCP intelligent sensors to one sensorProbe+ (up to 4 expansion units)

E-IS8N / E-IS8N-DIN - Technical Drawing

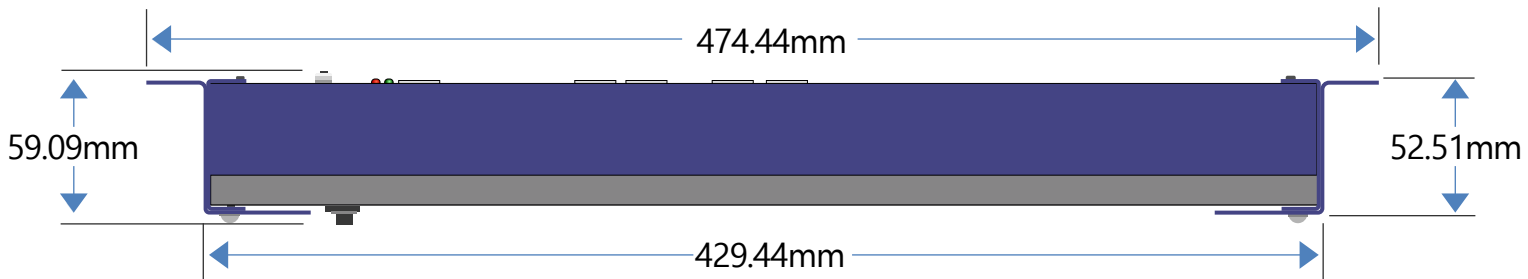
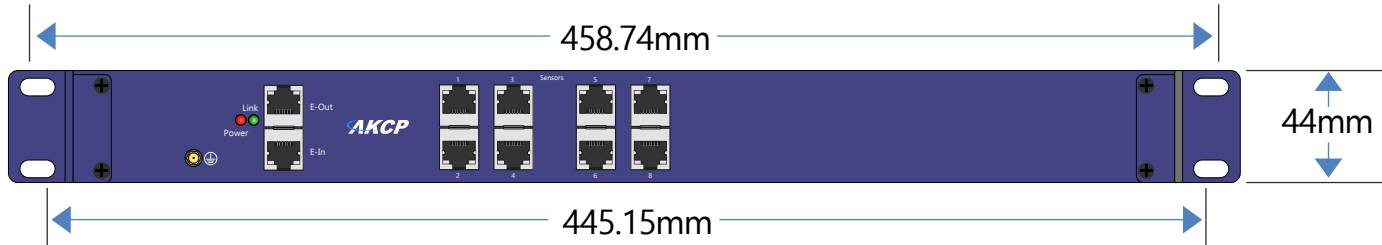

Optional DIN rail mounted version

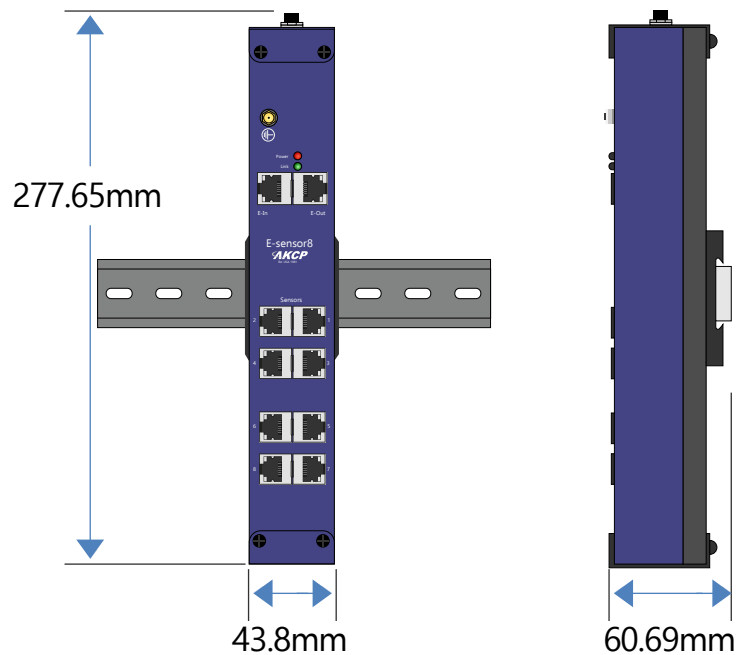
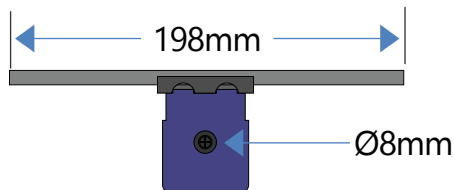

16x Opto-Isolated Dry Contacts (E-OP16)



Optically isolated Dry Contact Expansion Unit.

Add isolated dry contacts to your securityProbe or sensorProbeX+. If your main device is some distance from the contacts you wish to monitor, save money and time in cable infrastructure by installing the E-Opto16 close to the contacts you wish to monitor and run only a single CAT5 cable back to the base unit. E-Opto16 devices can be installed up to 1,000ft or 300m from the base unit and daisy-chained with a max distance of 1,000ft or 300 meters between each device.

Technical Specification

Dimension	Size 8.5 x 5.43 x 1.80 Weight 0.8 Kg
Expansion Port	2x RJ-45 Expansion Ports 115.2K bps Data Transfer Rate
Mounting	1U Rack Mount Standard Rack mount brackets included Compatible with AKCP's DIN and rack mount trays
Power	External 7.0 - 9 VDC 3A Power Adapter Input Voltage and Current ratings : 100V~240V - 1A Typical 5.025 Watt, 0.67A
Status Indication	LED indication for power LED for Expansion port connectivity LED for sensor online and dry contact status
Components	Manufactured using highly integrated, low power surface mount technology to ensure long term reliability.
Operating Environment	Temp : Min. -35° C – Max. +80° C Humidity : Min. 20% – Max. 80% (Non-Condensing)
MTBF	400,000 Hours
Inputs	16x 2 wire dry contact inputs configured as opto-isolated 16x 2 wire dry contact inputs support up to 50 Volts DC and 80mA of current 1x RJ-45 expansion module input (E-in)
Outputs	1 RJ-45 expansion module output (E-out)
E-Modules	* Daisy chain multiple E-modules including E-sensor8 and E-opto16 combined * Uses standard RJ-45 connections and CAT5 LAN cable * Maximum extension cable run length: 300 meters (1000 feet) * Compatible with AKCP's complete line of intelligent sensors * Connect up to 500 AKCP dry contact sensors to one securityProbe5ES * Connect up to 150 AKCP dry contact sensors to one sensorProbe+ (up to 4 expansion units)

E-OP16 - Technical Drawing

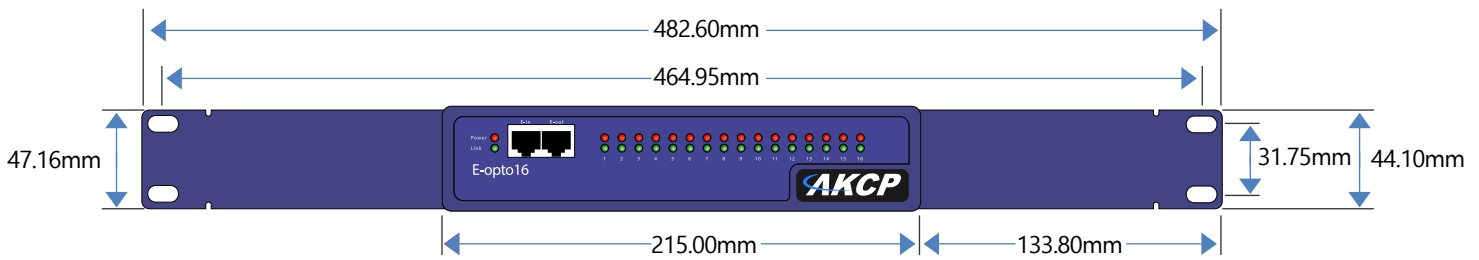
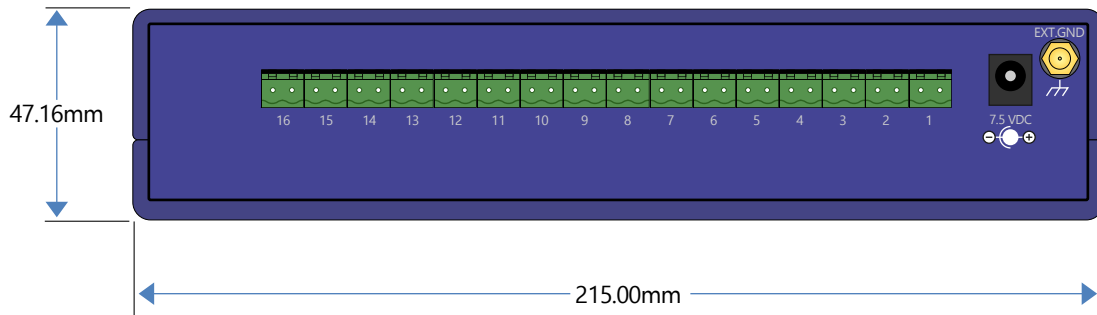
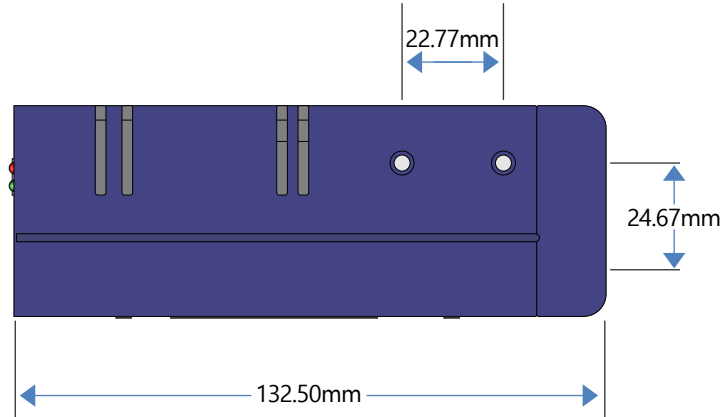
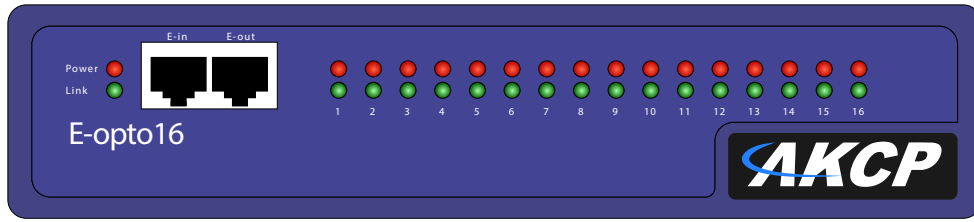

MAX 1,000 feet/300m

MAX 1,000 feet/300m

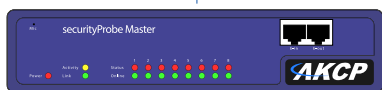

securityProbe (Master)

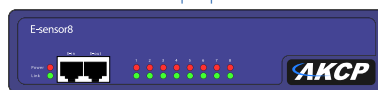

E-Sensor8 (EXP)







E-Opto16 (EXP)

Access Control

Doors and Cabinets

AKCP Access Control Solutions integrate closely with our central management software, AKCPro Server. Administer access users, rights, and schedules. Remotely lock and unlock doors, and synchronize sensor events with IP camera video feeds.

Compatible with a wide range of industry standard access control accessories, locks and readers. Control access to doors, industrial outdoor cabinets, remote sites and IT cabinets.

	Name	Code	Description
	Door Control Unit	DCU	Door, access readers and sensors
	Cabinet Control Unit	CCU	Expansion door controller for cabinets
	Swing Handle Lock	SHL	RFID Swing Handle Cabinet Lock
	Dual Authentication Swing Handle	SHL-DA	External keypad, RFID and MiFare reader with swing handle

Door Control Unit (DCU)



Control access and synchronize with video

With the DCU control access to 1 main door. RFID card readers, PIN card, Fingerprints or Dual Authentication can be configured by connecting suitable hardware. A sensor port is compatible with all AKCP sensors, including RFID swing handle locks.

Combine RFID swing handle locks with fingerprint readers for biometric cabinet access control.

DCU integrates with AKCPro Server Central Monitoring Software. This gives remote monitoring and control of doors and administration of users and access privileges. Access events are synchronized with IP video camera feeds for event based recording.



Door Control Unit

DCU - Wiring Diagram

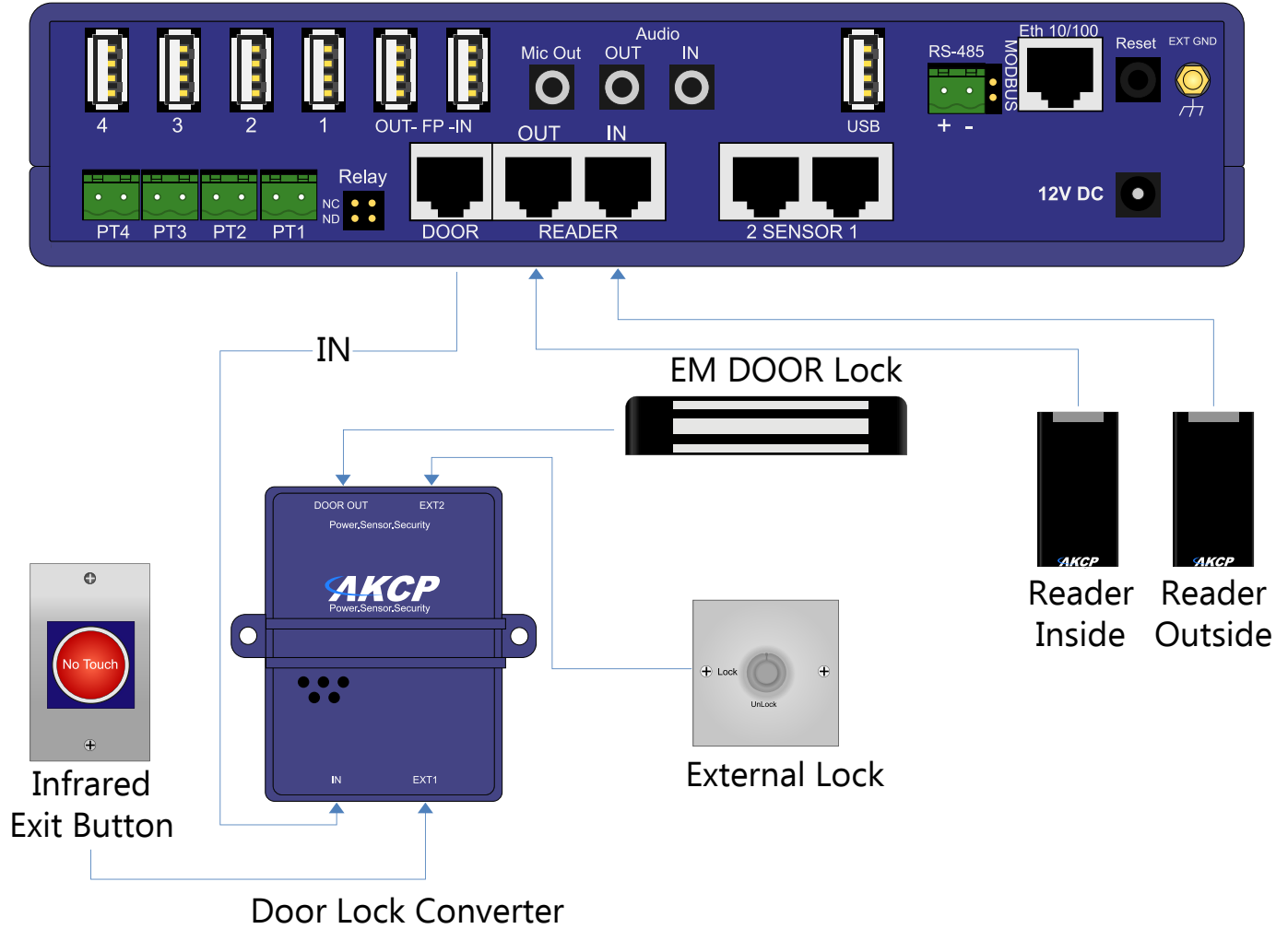

DCU - Door Control Unit Accessories

Door Control Unit Accessories

DCU is compatible with a wide range of access control accessories. Purchase the door controller to go with existing standard Weigand RFID card readers and keypads, or 12VDC locks.

AKCP can supply a complete door package including locks, readers and accessories. Choose from a range of door locks, fail safe or fail secure, bolt type or electromagnetic locks.



Door Locks



Access Readers



Manual Key



RFID Swing Handle



Exit Buttons

DCU - Technical Specification

Dimension	Size 8.5 x 5.43 x 1.80 Weight 1 Kg
Expansion Port	2x RJ-45 Expansion Ports 115.2K BPS Data Transfer Rate Simultaneous functionality between Expansion Ports & RS485 port threshold status
Mounting	1U Rack Mount Standard Rack mount brackets included Compatible with AKCP's DIN and rack mount trays
Power	External 12 VDC 3A Power Adapter Input Voltage and Current ratings : 100V~240V - 1A Typical 5.025 Watt, 0.67A
Status Indication	LED indication for power LED for network connectivity LED for sensor online and threshold status LED for Door Status
Components	Manufactured using highly integrated, low power surface mount technology to ensure long term reliability. CPU: AKCP i.MX25 Processor 128 MB On-Board NAND Flash HC SD Memory Slot on-board (up to 16GB)
Operating Environment	Temp : Min. -35° C – Max. +55° C Humidity : Min. 20% – Max. 80% (Non-Condensing)
MTBF	400,000 Hours
Connectivity	Ethernet 10/100 Mbps Optional Internal 3G/4G modem
Inputs	2x RJ-45 Sensor Ports 2x RJ-45 Expansion Ports 1x USB 2.0 Modem Port 4x Video Ports 2x Fingerprint Ports (when using Fingerprint Readers it is recommended that only x2 Video Ports are enabled.) 2x Wiegand 26 Ports 4x PTZ Two Pin Controllers Internal Microphone Audio In (Analog) 2.5 jack RS485, 2 Pin Terminal box, (used for Modbus)
Outputs	Configurable output signals (0VDC/5VDC) on any of the 2 RJ-45 sensor ports Internal Speaker Out Ext. Speaker Out, 2.5" jack (Analog) Mic Out, 2.5 jack (Analog) (For modem application) Door control port
Expansion Boards	8 Port Intelligent Sensors Module (E-Sensor8) 16 Port Dry Contacts Module (E-opto16) (Maximum of 500 Sensors) Cabinet Control Unit (DCU) (Up to 25 Per Chain) Extendable up to 1,000 Feet or 300 meters Expansion modules are daisy chainable 4x AKCP High Definition Digital camera USB input
Video- HD Digital	* resolution 320x240 or 640x480 4x PTDC controller ports
Important Note	Requires the AKCPro Server for Access Control and Sensor Port configurations

DCU - Technical Drawing

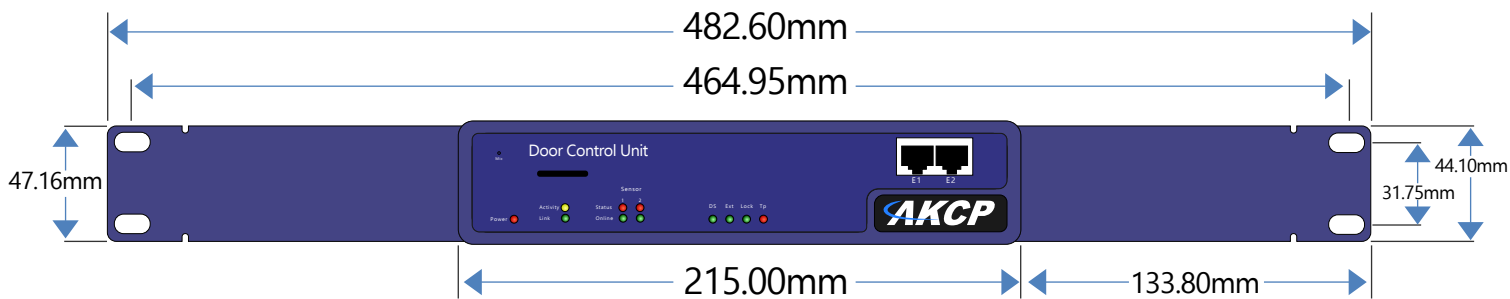
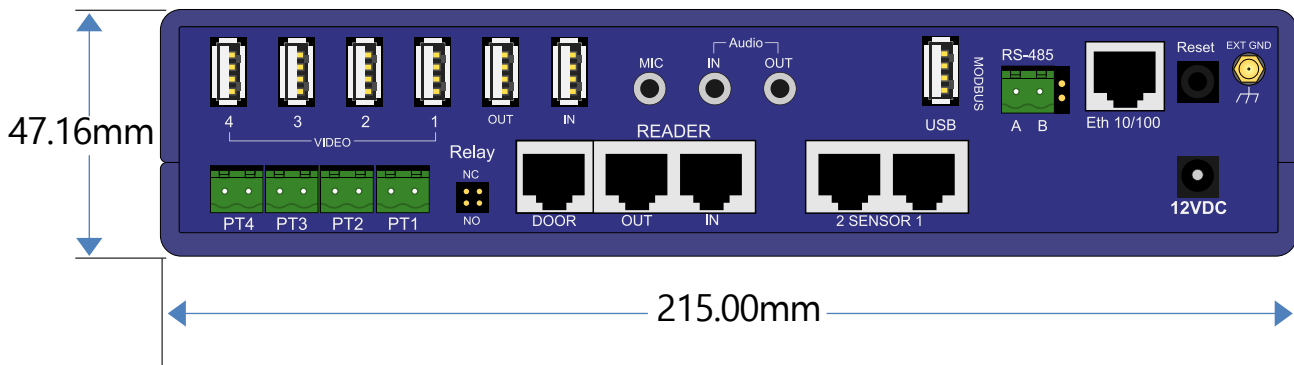
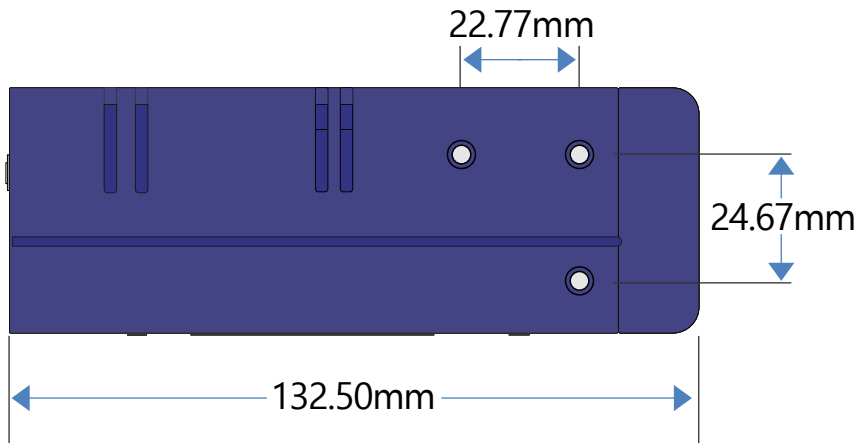

Door Control Unit

Cabinet Control Unit (CCU)

Cabinet Access Controller

The CCU is a compact door access controller. Working on our Expansion Technology, it connects to the Expansion port of any SEC5E, DCU or SPX+, providing a cost effective way to add access control to your facility and monitoring in a single platform together with your environmental sensors. The CCU can be used on any doors, and also computer cabinets, or other types of cabinets where the swing handle lock can not be installed, or an electromagnetic type lock is preferred.



Technical Specification

Dimension	Size : 13.20 cm x 5.38 cm x 3.40 cm Weight : 0.15 Kg
Expansion Port	2x RJ-45 Expansion Ports 115.2K bps Data Transfer Rate
Mounting	Rack mount brackets included Compatible with AKCP's DIN and rack mount trays
Power	External 12 VDC >= 1A Power Adapter Input Voltage and Current ratings : 100V~240V - 1A Typical 6 Watt, 0.5 A
Status Indication	LED indication for power LED for Expansion port connectivity
Components	Manufactured using highly integrated, low power surface mount technology to ensure long term reliability.
Operating Environment	Temp : Min. -35° C – Max. +55° C Humidity : Min. 20% – Max. 80% (Non-Condensing)
MTBF	400,000 Hours
Inputs	2x RJ-45 ports for connecting AKCP sensors 1x Wiegand RFID Reader 1x Door Lock Control. 1x RJ-45 expansion module input (E-in)
Outputs	1 RJ-45 expansion module output (E-out)
E-Modules	* Daisy chain multiple E-modules including E-sensor8 and E-opto16 combined * Uses standard RJ-45 connections and CAT5 LAN cable * Maximum extension cable run length: 300 meters (1000 feet) * Compatible with AKCPs complete line of intelligent sensors * Connect up to 500 AKCP sensors to one securityProbe5ES * Connect up to 150 AKCP sensors to one sensorProbe+ (up to 4 expansion units)
Supported Lock Rating	The CCU can control a 12V Door Lock with a maximum current draw no greater than 500mA.
Important Note	Requires the AKCPro Server for Access Control and Sensor Port configurations

CCU - Wiring Diagram

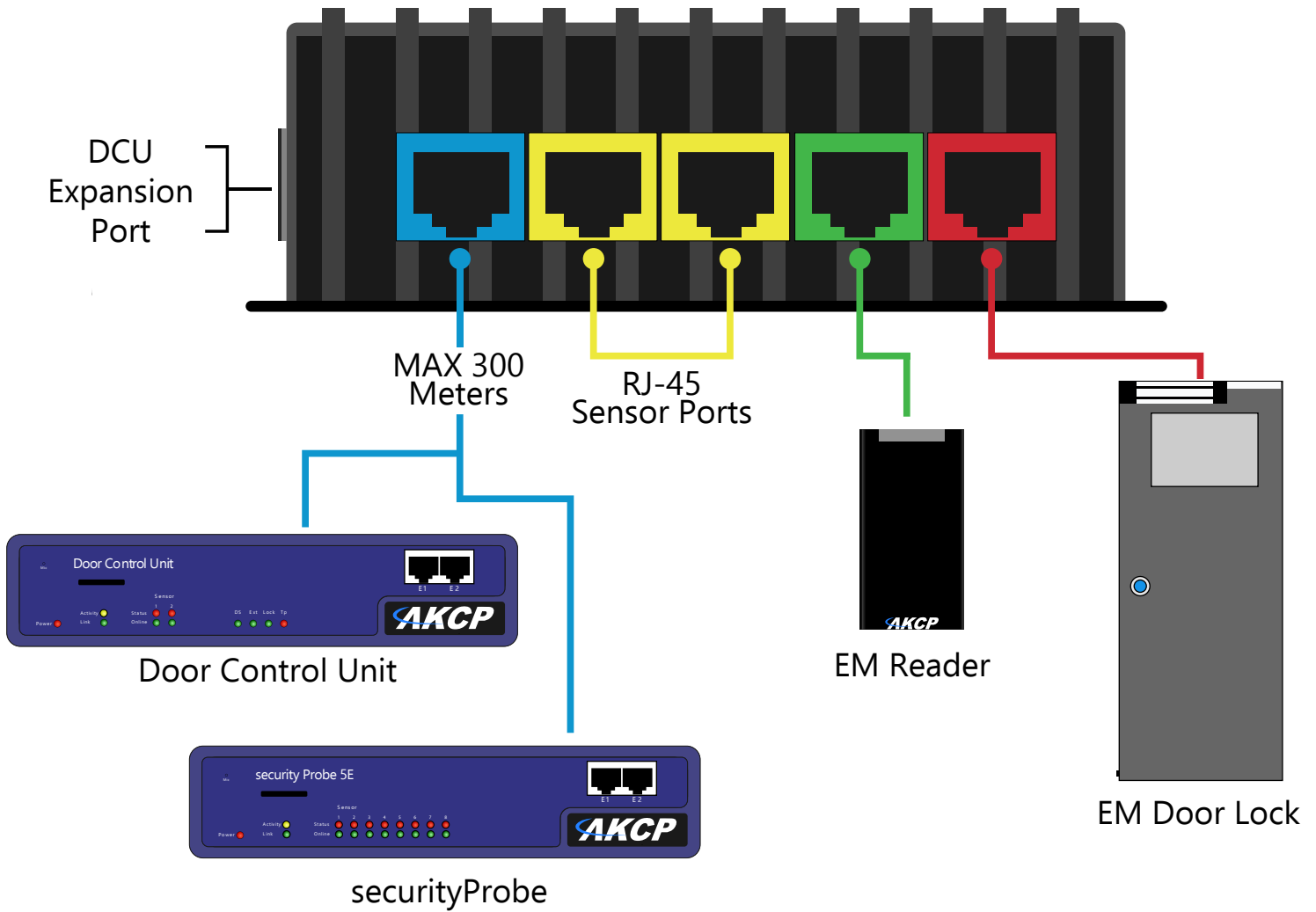

The CCU can be connected to the Expansion port on either the SEC5E, DCU or SPX+

DCU - Technical Drawing

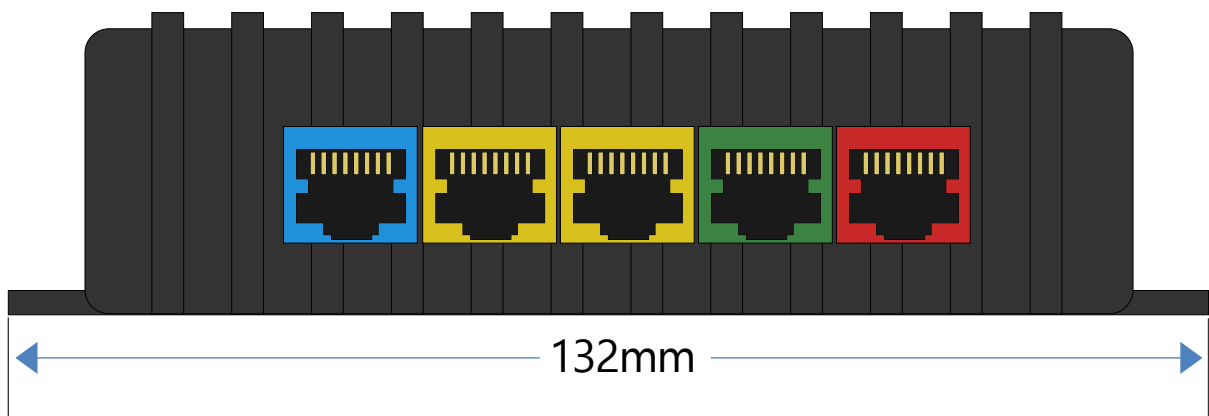
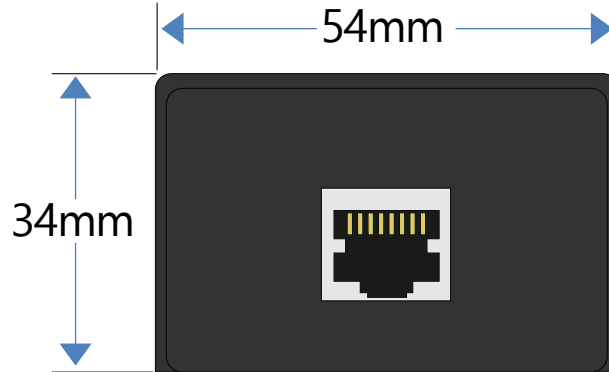
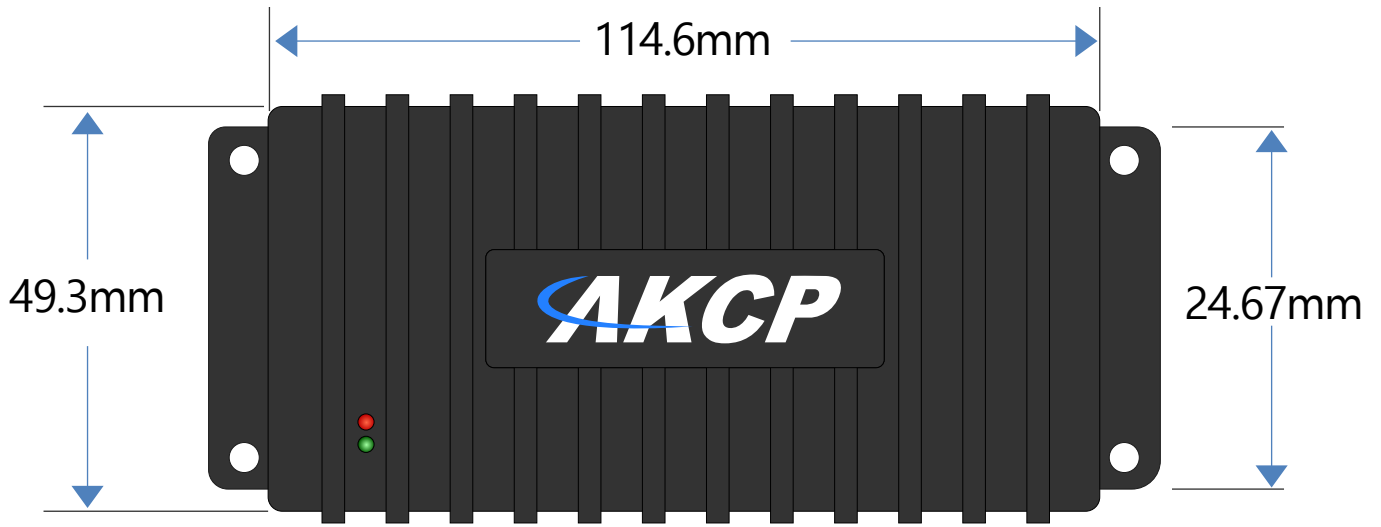

Swing Handle Lock (SHL / SHL01 / SHL-DA)

Cabinet Swing Handle Access Control

The Swing Handle Lock is compatible with a wide range of industry standard computer cabinets, making it a simple to install upgrade for your data center. Equipped with an RFID reader, you can control and monitor access to your computer cabinets from a centralized software platform (AKCPro Server).

Keep an audited trail of who entered what cabinet and when, how long they were there and be alerted if cabinets are left unlocked. Additional security sensors can monitor side panels. A manual keylock override is provided, and also monitored for use.

Swing Handle Lock is compatible with all sensorProbe+ base units, with a maximum of 12 handles per device. Packages of two handles (SHL01) can be ordered for controlling access to both front and rear of the cabinet.

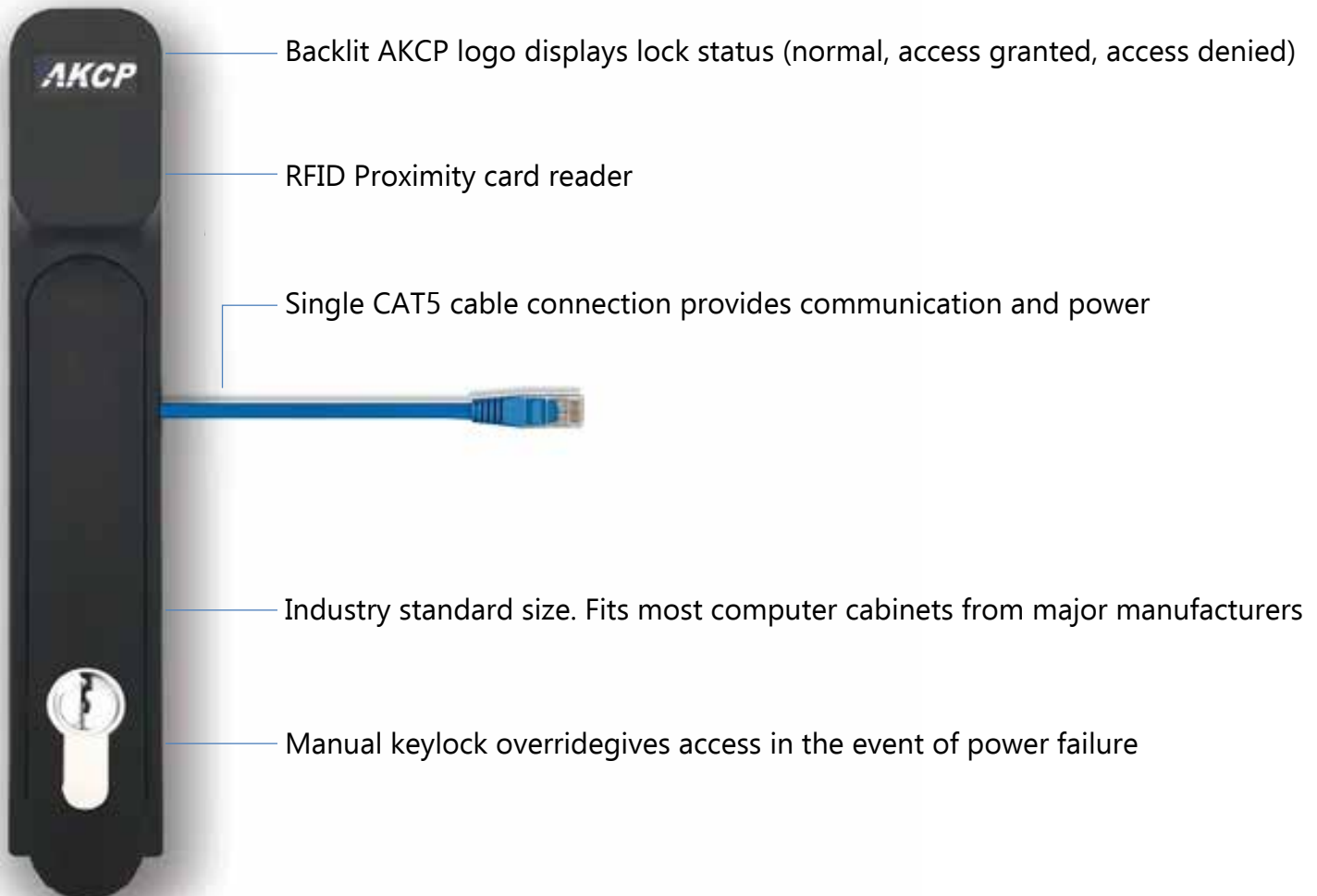

Swing Handle Lock (SHL / SHL01 / SHL-DA)

A maximum of 12 swing handle locks can be connected to a single SPX+. Each swing handle lock comes with one security sensor for sensing the cabinet door position. Additional security sensors can be added to monitor side panels and rear cabinet doors also.

Up to 4 Security Sensors per Swing Handle

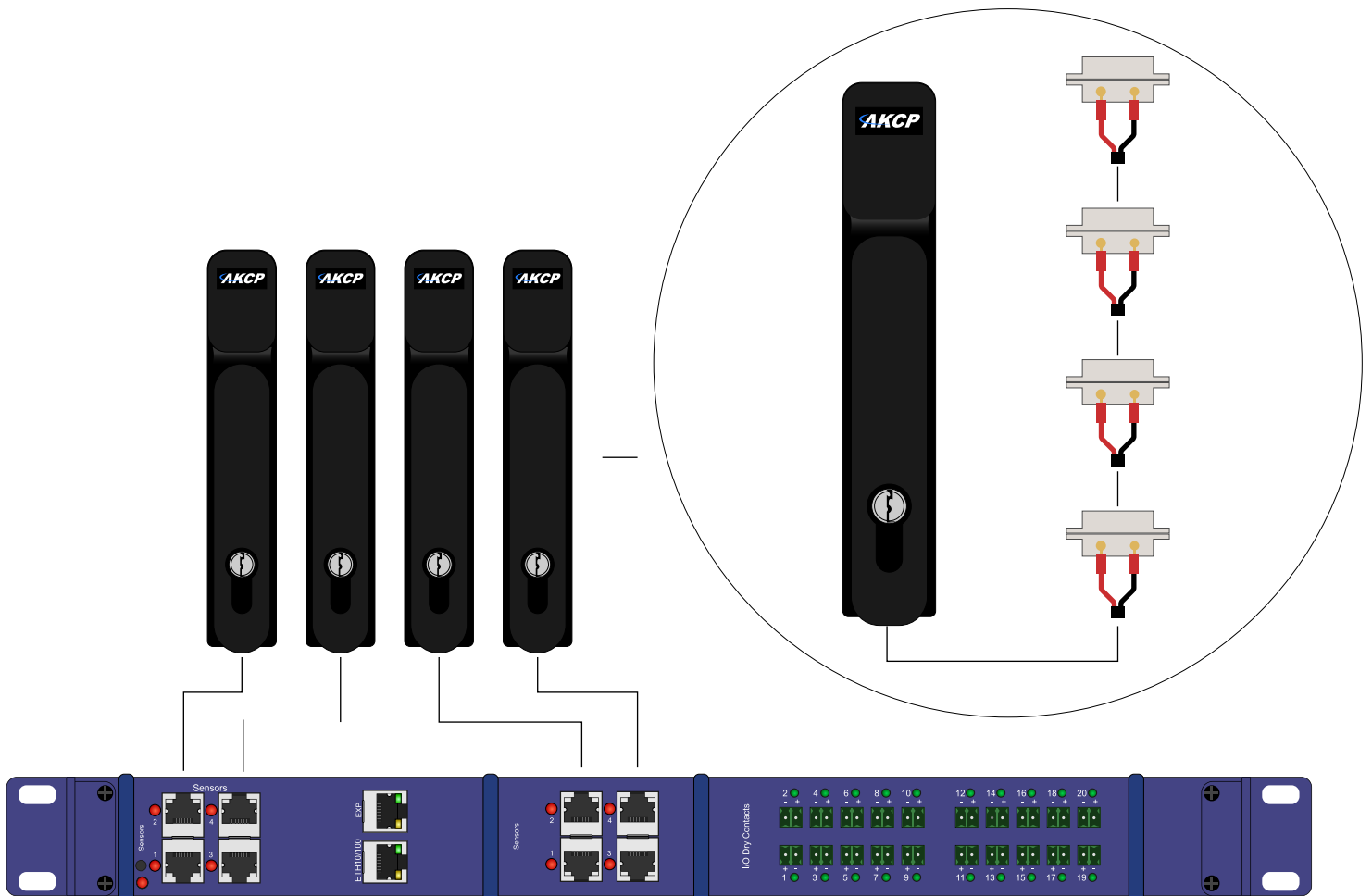

Swing Handle Lock (SHL / SHL01 SHL-DA)



The Swing Handle Lock with Dual Authentication, allows you to require both a PIN number and an RFID card, or only the PIN number, in order to access the lock. Useful for remote cabinets, no need to distribute RFID cards, a one time access PIN can be assigned.

The SHL-DA can also have third party MiFare and HID card readers plugged in for customers who are using these type of encrypted RFID cards.

A maximum of 2 SHL-DA can be connected to a single SPX+ or SP2+.

SHL-DA Technical Drawing

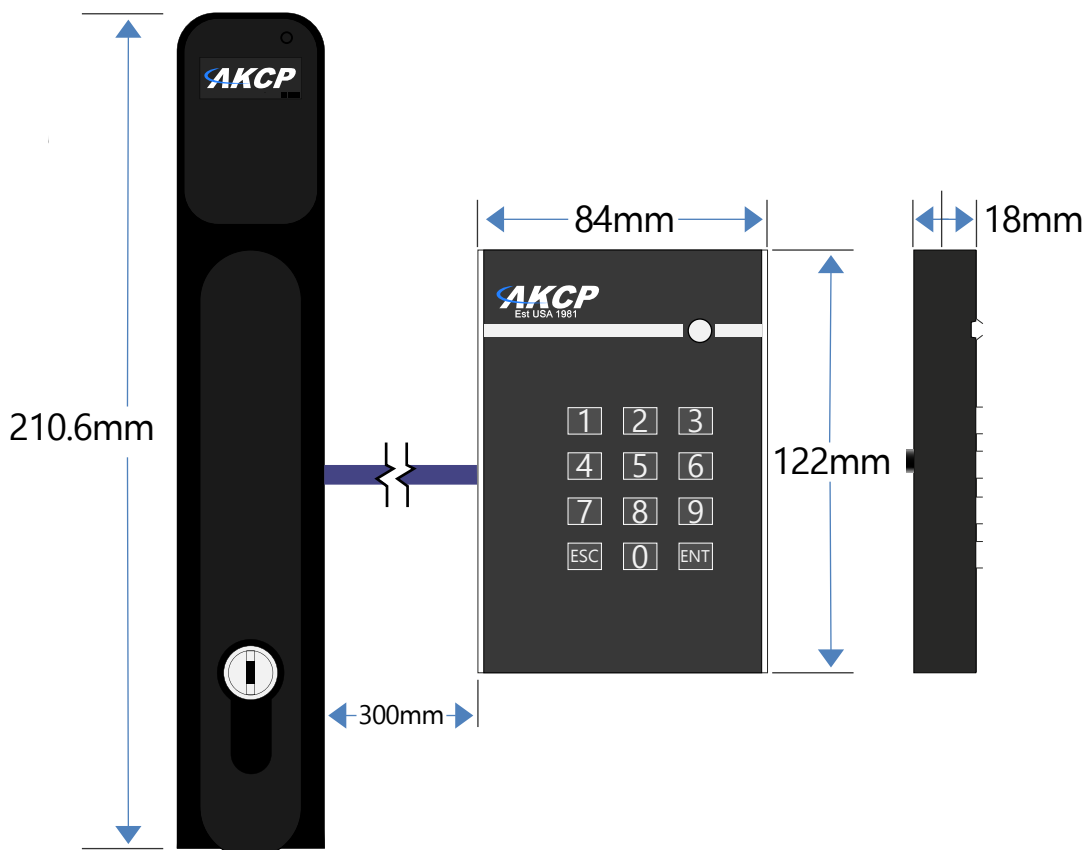

SHL / SHL01 - Technical Specification

Card Reader	
Supported Cards	EM-Card, 125Khz Proximity cards, 26bits K4100/EM4100/EM4200/T5577
Proximity Reading Range	0-3cm
Handle Lock	
Access Control	Up to 500 users
Ambient Temperature	-25°C to 75°C
Ambient Humidity	10%-90%
Built-In	RFID Antenna, Motor
Fail-Secure	Integrated key lock for manual override
LED indicator	RGB Color LED : Lock status and Access Control status
Locking Control	Remote lock and unlock from the sensorProbe+ unit via Web Interface, SNMP or AKCPro Server Calendar enabled locking and unlocking control Notification locking and unlocking control
Interface	
Communication cable	RJ-45 jack to sensor using UTP CAT5e/6 cable
Power source	Powered by the sensorProbe+ family units. No additional power needed
Power Consumption	Typical 0.35 mWatt, 70 mA Peak 1.75 mWatt, 350 mA
Working Voltage	DC 5V
Maximum Cable Length	Run length is 12 feet (5 meters) with approved low capacitance shielded cable or UTP
Dimensions	210.6 x 37.0 x 43.8 mm
Important Note:	sensorProbe+ units auto detects the presence of the RFID Swing Handle Lock sensor
	Up to 12 RFID Swing Handle Lock sensors per sensorProbe+ unit
	- The RFID Swing Handle Lock sensor is only compatible with the sensorProbe+ platform units. - When plugging the first time or after upgrading a sensorProbe+ unit, the sensor's firmware might be upgraded by the unit and not be available right away. Firmware updates can only be performed on the main sensor module (first 4 sensor ports)
Sensor count	2

SHL-DA Technical Specification

Card Reader	
Supported Card Reader	+ AKCP Keypad EM Reader + 3rd Party Readers : miFare, HID, EM Proximity with CardID wiegand output on 26bits, 30bits 32bits
Supported Cards	AKCP EM Reader : EM-Card, 125Khz Proximity cards, 26bits K4100/EM4100/EM4200/T5577
Proximity Reading Range	0-5cm
Handle Lock	
Access Control	Up to 500 users Authentication : Card or Card+PinCode
Ambient Temperature	-25°C to 75°C
Ambient Humidity	10%-90%
Built-In	Motor
Fail-Secure	Integrated key lock for manual override
LED indicator	RGB Color LED : Lock status and Access Control status
Locking Control	Remote lock and unlock from the sensorProbe+ unit via Web Interface, SNMP or AKCPro Server Calendar enabled locking and unlocking control Notification locking and unlocking control
Interface	
Communication cable	RJ-45 jack to sensor using UTP CAT5e/6 cable
Power source	Powered by the sensorProbe+ family units. No additional power needed
Power Consumption	Typical 800 mWatt, 160 mA Peak 1.75 Watt, 350 mA
Working Voltage	DC 5V
Maximum Cable Length	Run length is 12 feet (5 meters) with approved low capacitance shielded cable or UTP
Dimensions	210.6 x 37.0 x 43.8 mm
Important Note:	sensorProbe+ units auto detects the presence of the RFID Swing Handle Lock sensor Up to 2x RFID Swing Handle Lock + Wiegand Reader sensors per sensorProbe+ unit - The Swing Handle Lock sensor is only compatible with the sensorProbe+ platform units. - When plugging the first time or after upgrading a sensorProbe+ unit, the sensor's firmware might be upgraded by the unit and not be available right away.
Sensor count	2

SHL / SHL01 - Cutout Pattern

The below template outlines the size of the hole required in your cabinet to fix the Swing Handle Lock.

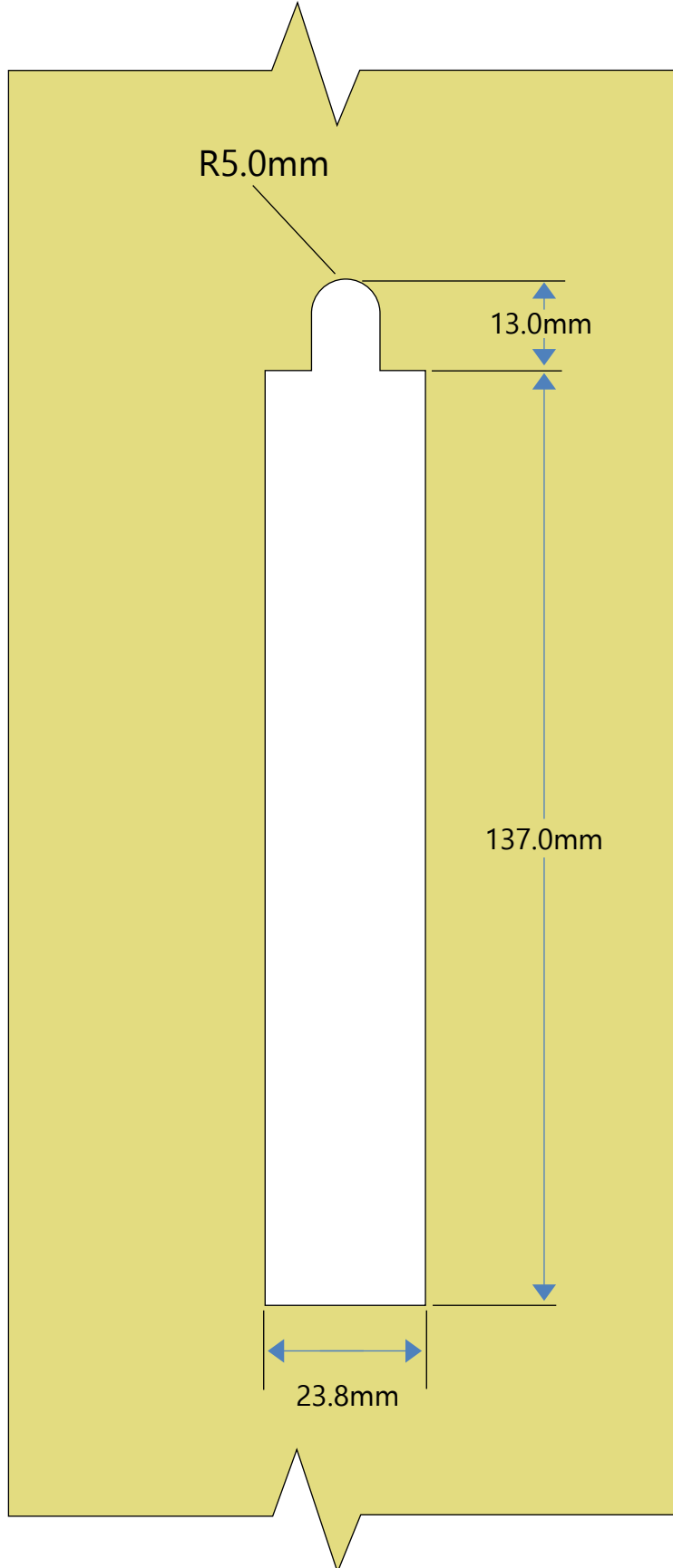

SHL / SHL01 - Technical Drawing

The below template outlines the size of the hole required in your cabinet to fix the Swing Handle Lock.

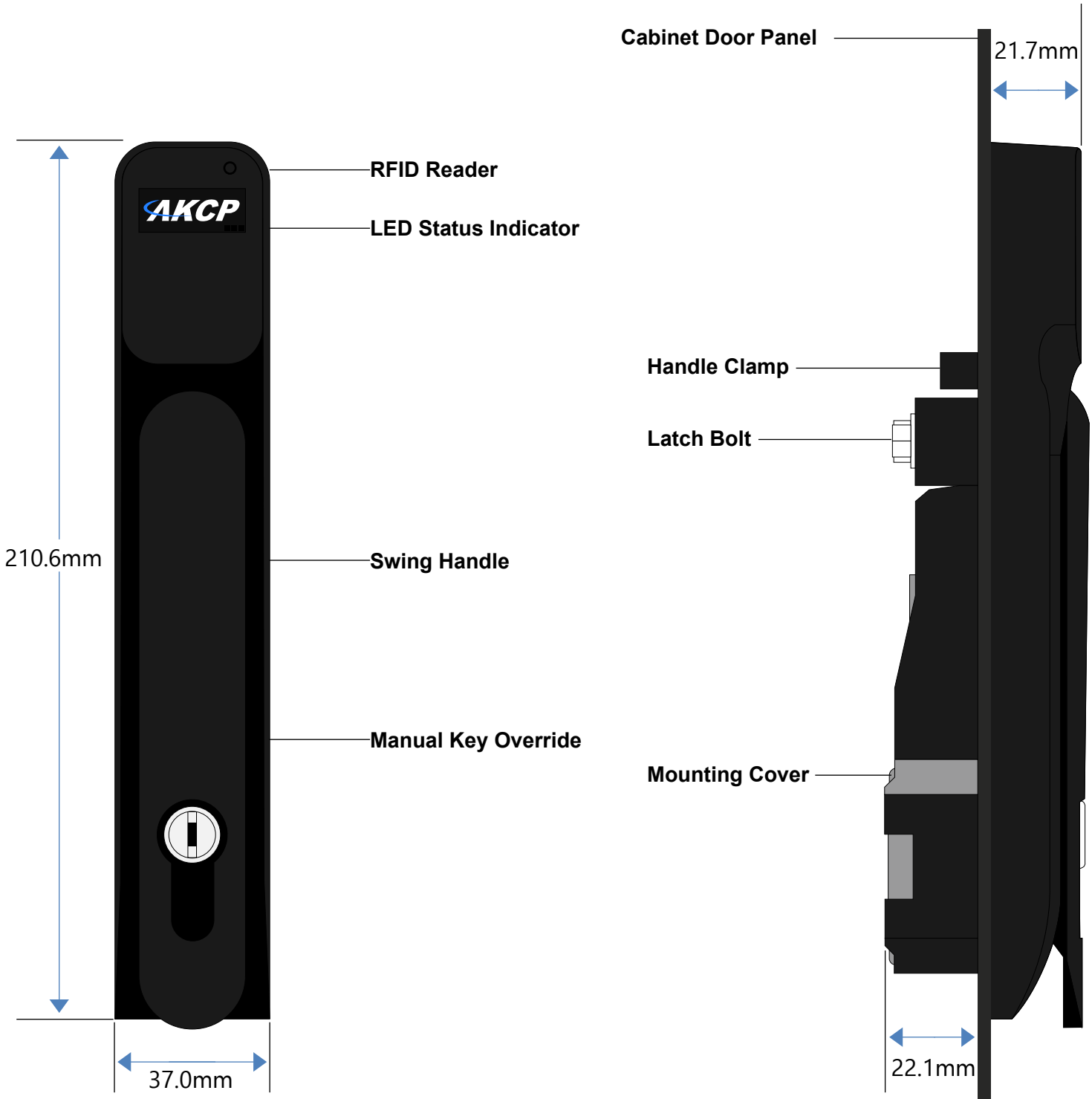

Wireless Tunnel™

Long Range, Low Power



The world's most advanced LoRa™ solution

The AKCP Wireless Tunnel™ Technology builds on standard LoRaWAN™ with our own proprietary software and hardware. Sensors can be battery powered (3x AAA batteries not included) or via a 5VDC input.

Wireless Tunnel™ Advantages

- Rapid deployment
- Save on cabling and installation costs
- Fewer base units and IP addresses
- Easy to expand with future requirements
- Can be run on batteries if in difficult to power locations*

The world's most advanced LoRa™ solution

	Name	Code	Description
	sensorProbe+ Wireless Tunnel™ Server	SP-WTS	Wireless Tunnel™ Server. Connect with up to 30 SP-WT with built in monitoring server.
	sensorProbe+ Wireless Tunnel™	SP-WT	Connect up to 4x AKCP intelligent sensors to a single Wireless Tunnel radio

* Battery life depends on environmental conditions, how often sensor is set to broadcast and how often alerts are generated

Wireless Tunnel™

Wireless Tunnel™ Technology

Wireless Tunnel™ radio is an energy efficient, long range and low cost bi-directional communications technology. Radio frequency modulation provides deep indoor penetration through walls, elevator shafts and basements. AKCP have introduced proprietary algorithms increasing efficiency and reliability of the wireless solution, applicable for critical infrastructure monitoring.

- Immediate broadcast upon sensor status change
- "Listen before talk" to minimize packet collisions
- Queuing and Re-Broadcast of undelivered messages
- Increased battery life by using less airtime with shortest spread factor
- Shorter airtime means more frequent broadcasts are possible
- Tuned antennas, maximum range with shortest spreading factor

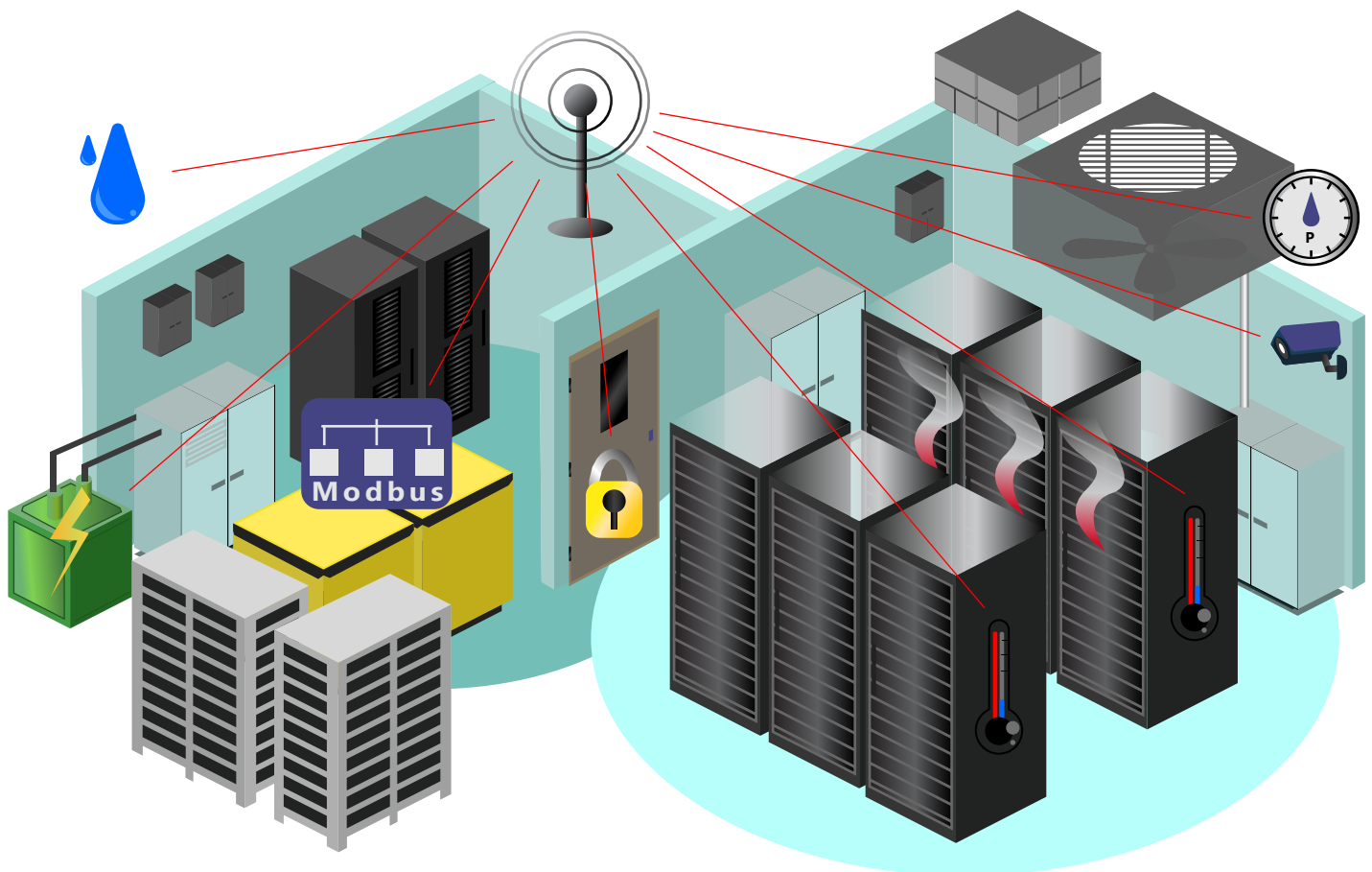

Example Deployment of the Wireless Tunnel™ system in data center

sensorProbe - Wireless Tunnel™ Server (SP-WTS)

Collect up to 30 Wireless Tunnel™ Sensors

sensorProbe Wireless Tunnel™ Server collects, stores and graphs data from all AKCP wireless sensors. Ethernet connectivity to access sensor data via the web UI, SNMP, Modbus TCP/IP or MQTT. AKCPro Server provides central monitoring of multiple gateways.

Optional:

- PoE
- 4G Cellular Modem and GPS
- Modbus RS485 port



5VDC POWER

SENSOR PORT

ETHERNET

SP-WTS - Options

SP-WTS comes supplied with mounting options for DIN rail, wall hanging, magnetic mounting and free standing feet. It can also be equipped with a 4G cellular data modem.

Optional:

PoE

4G Cellular Modem and GPS

Modbus RS485 port

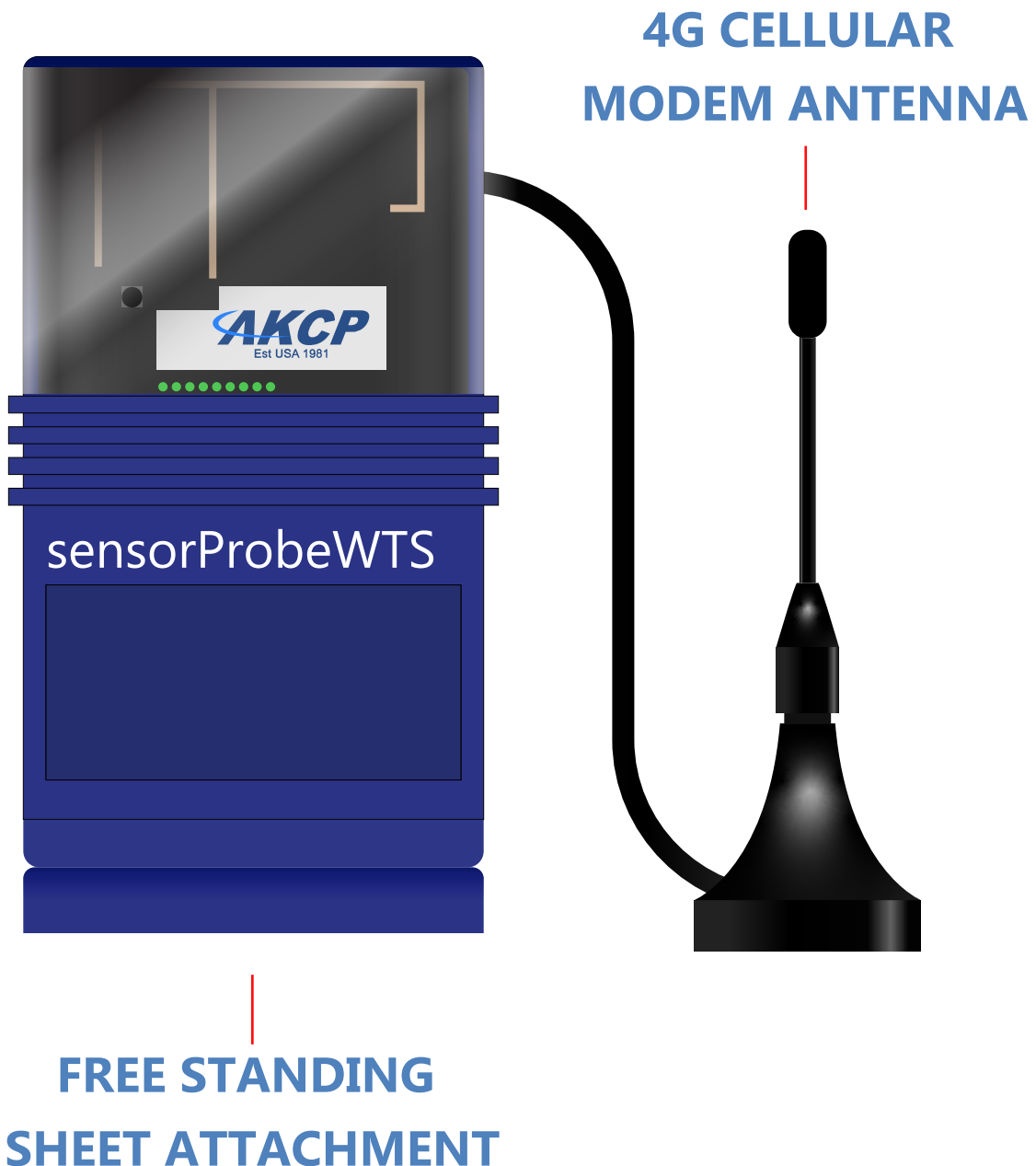

SP-WTS - Technical Specification

Status Indication	LED indication for power LED for Radio connectivity LED for Status
Components	Manufactured using highly integrated, low power surface mount technology to ensure long term reliability
Operating Environment	Temperature : Min. -15° C – Max.50° C Humidity: Min. 20% – Max. 80% (Non-Condensing)
MTBF	1,400,000 Hours based on field experience with sensorProbe units.
Connectivity	Ethernet 10/100 Mbps Optional Integrated 4G cellular modem with external antenna Optional GPS with external antenna (requires 4G modem)
Inputs	1x USB for LoRa devices adding/software upgrade 1x 10/100 Ethernet Port 3x intelligent sensor ports for connecting AKCP wired sensors Optional Modbus RS485
LoRa (R) Radio Regional plans	- EU868 : 863~868Mhz Max TX Power +14dBm Duty Cycle 1% - US915: 903~915Mhz Max TX Power +20dBm - AS923 : 920~925Mhz Max TX Power +14dBm Duty Cycle 1% - KR920 (Korea) : 922~923Mhz Max TX Power +14dBm Duty Cycle 1% - IL917 (Israel) : 915~917Mhz Max TX Power +14dBm Duty Cycle 1%
Certification	FCC Part 15C, CE EN300220-2
Software features	- up to 30 Wireless device connected - up to 32 Wireless sensors can be graphed - Total of up to 400 sensors can be online (Wireless and Virtual)
Power	External USB 5.5V 3A Power Adapter
Dimension	111 (W) x 62 (H) x 87 (D)
Mounting	Desktop, wall mount, DIN rail, Magnetic

SP-WTS - Technical Drawing

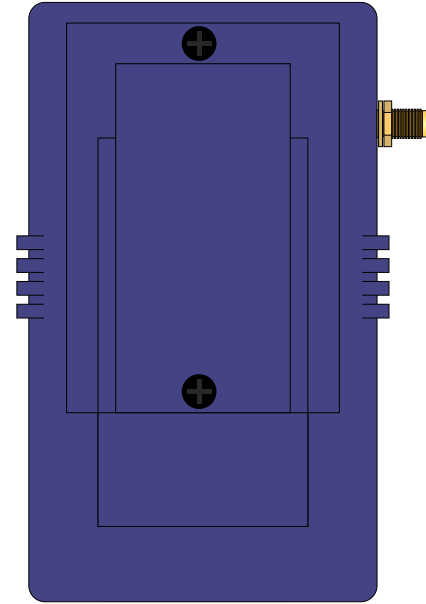
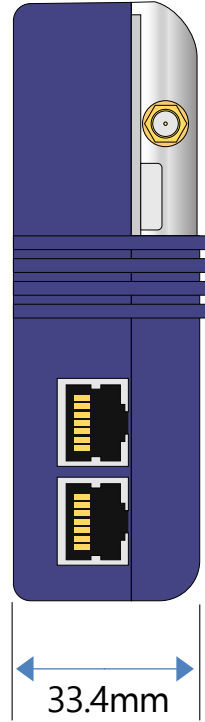
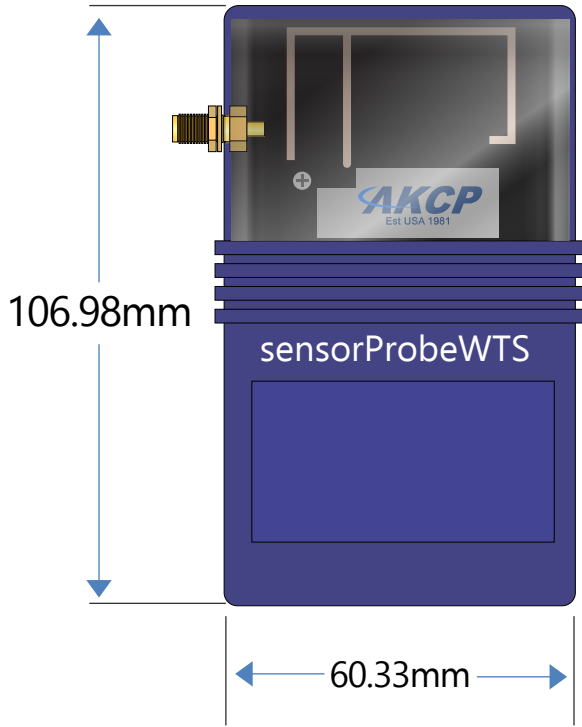

sensorProbe - Wireless Tunnel™ (SP-WT)

Connect up to 4 AKCP Intelligent Sensors

sensorProbe Wireless Tunnel™ allows you to connect up to 4 AKCP Intelligent sensors to a single radio. Communicate sensors over long distance with LoRa™ based wireless communications. AKCP's proprietary Wireless Tunnel™ protocol provides guaranteed message delivery without loss of data and low power utilization for superior battery life.

Build your own private LoRa based network without the need for any cloud services. Data is transmitted to the sensorProbe Wireless Tunnel Server (SP-WTS). Multiple SP-WTS can be monitored centrally with AKCPro Server, which can run locally or on a cloud service.



5VDC Input
EXT Battery
pack Input

SENSOR PORTS

5VDC POWER

SENSOR PORT

SP-WT - Technical Specification

Status Indication	LED indication for power LED for Radio connectivity LED for Status
Components	Manufactured using highly integrated, low power surface mount technology to ensure long term reliability.
Operating Environment	Temperature : Min. -15° C – Max.50° C Humidity: Min. 20% – Max. 80% (Non-Condensing)
MTBF	1,400,000 Hours based on field experience with sensorProbe units.
Connectivity	Wireless Tunnel™ connection to sensorProbe-Wireless Tunnel Server (SP-WTS)
Inputs	1x USB for external 5VDC power 1x 5VDC Terminal for external power or external battery pack 4x intelligent sensor ports for connecting AKCP wired sensors 3x intelligent sensor ports and 1x 4-20mA input* 3x intelligent sensor ports and 1x Modbus input*
LoRa (R) Radio Regional plans	- EU868 : 863~868Mhz Max TX Power +14dBm Duty Cycle 1% - US915: 903~915Mhz Max TX Power +20dBm - AS923 : 920~925Mhz Max TX Power +14dBm Duty Cycle 1% - KR920 (Korea) : 922~923Mhz Max TX Power +14dBm Duty Cycle 1% - IL917 (Israel) : 915~917Mhz Max TX Power +14dBm Duty Cycle 1%
Certification	FCC Part 15C, CE EN300220-2
Power	External 5.5V 3A Power Adapter AKCP External Battery Pack with 6x AAA batteries (non rechargeable)* 3x AAA Batteries (non-rechargeable)
Dimension	111 (W) x 62 (H) x 87 (D)
Mounting	Desktop, wall mount, DIN rail, Magnetic
* Optional feature on custom units	

SP-WT - Technical Drawing

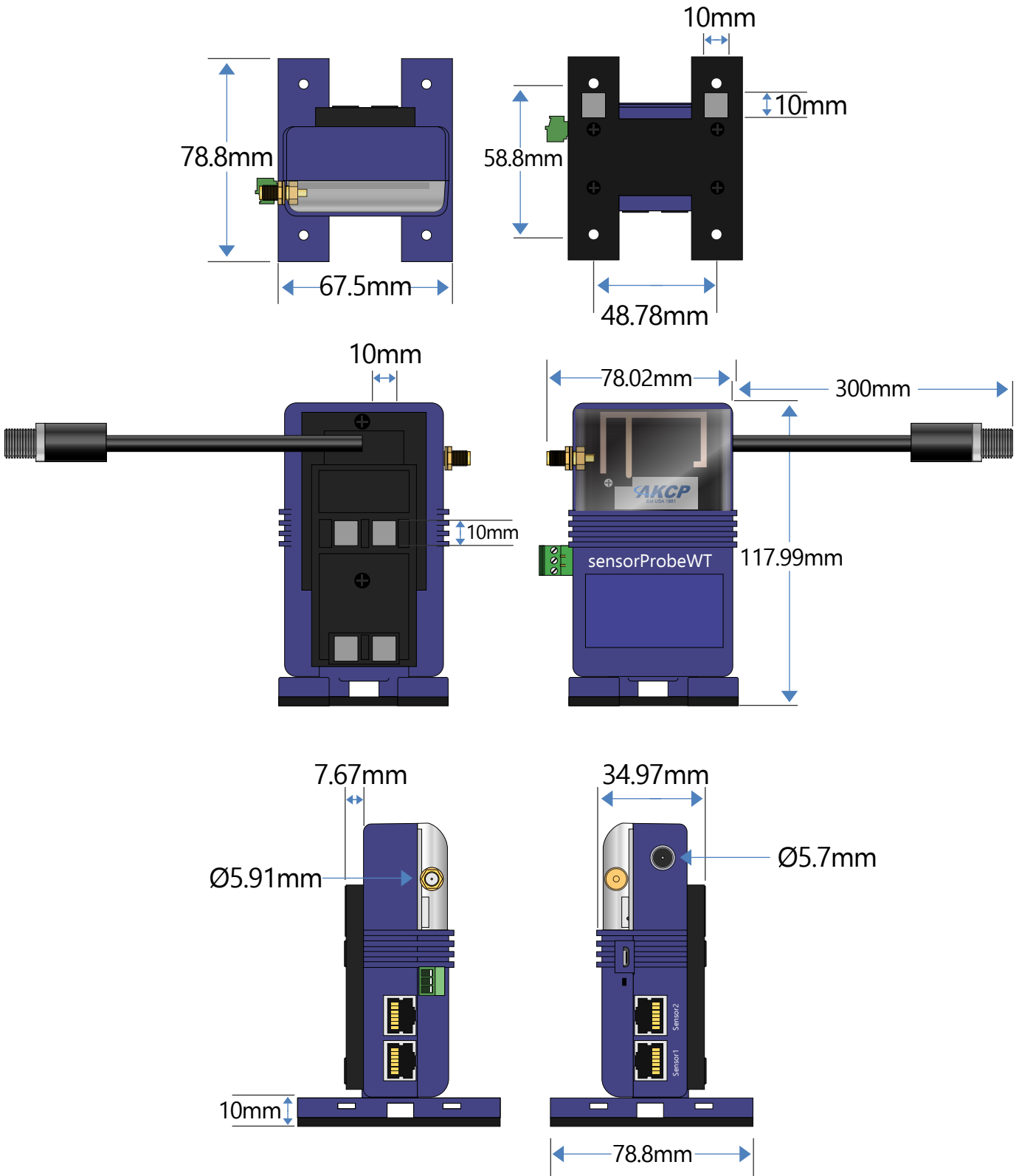

SP-WT-EXTBAT - Technical Drawing

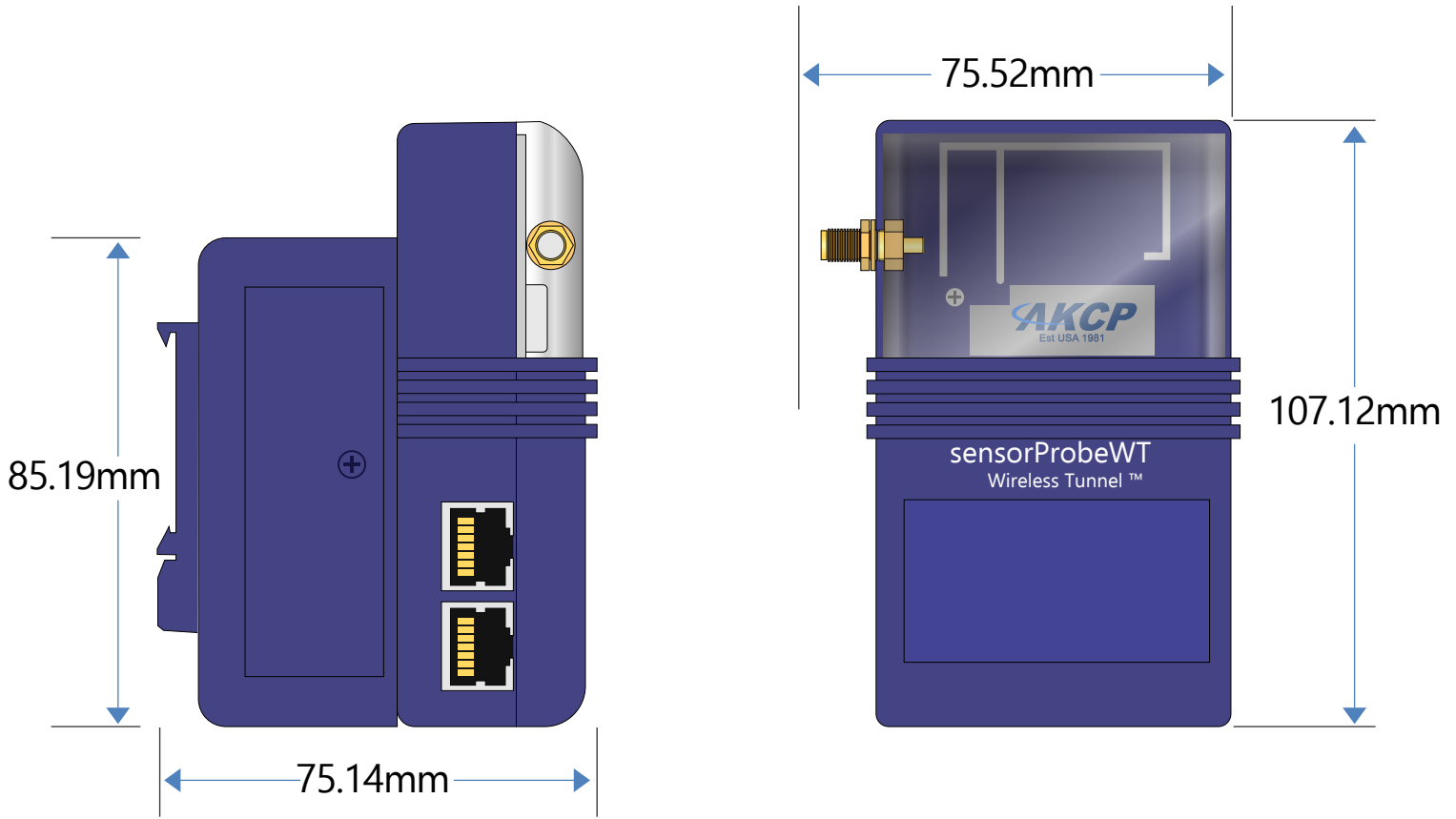

AKCPro Server (APS)

Connect up to 4 AKCP Intelligent Sensors

World Class Infrastructure Management Software AKCPro Server is our central monitoring and management software. Monitor your infrastructure, whether it be a single building, or remote sites over a wide geographic area. Integrate third party devices with, Modbus. Support for ONVIF compatible IP cameras.

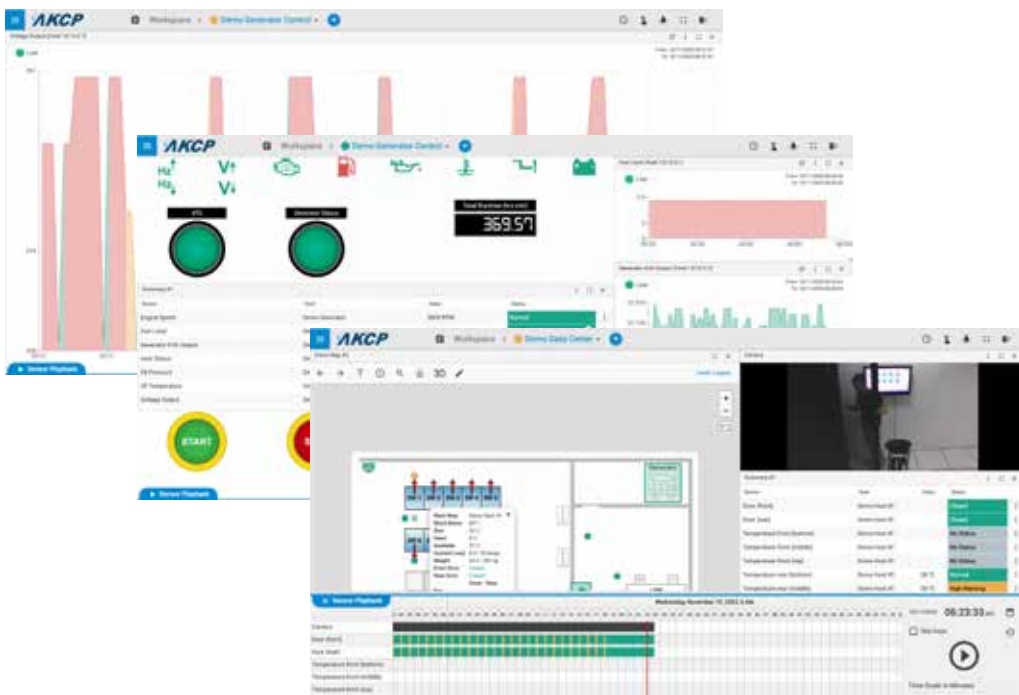

AKCP base units and sensors can be configured and monitored from AKCPro Server. Base units and Wireless Tunnel™ Gateways communicate with through your local network (LAN) or wide area network (WAN). Remote sites with no wired network send data to the server through the cellular data network* via a VPN connection.

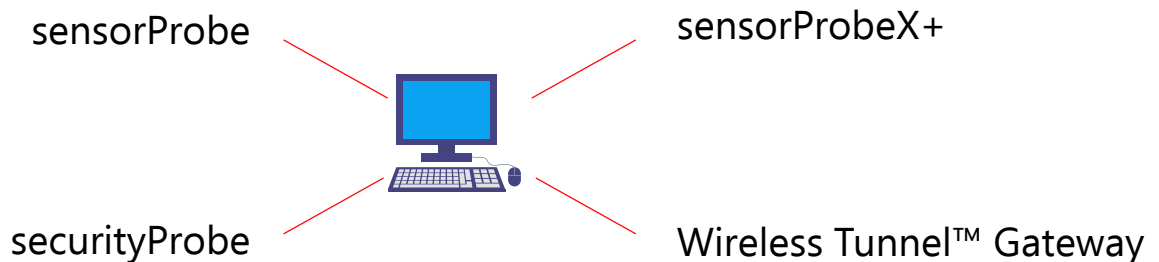

*Require base unit with cellular data 3G/4G modem

AKCP Pro Sever - Management

Access from your PC, Tablet or Smart Phone

AKCPro Server can be accessed on your smartphone, tablet or PC. Access is operating system independent through the HTML5 user interface on your web browser*. There are no clients or special apps to install, making it easy to view your data on the go.



Chrome



Firefox

Remote Site Management

When sites are spread over a wide geographic area and monitoring from a single central office, AKCPro Server is the ideal choice. AKCP base units at remote sites can communicate over a wired or cellular data connection, sending data on connected sensors back to the main server. Remote monitoring of Modbus devices, generators and any SNMP compliant devices can be done through virtual sensors on APS.

AKCPRO Server

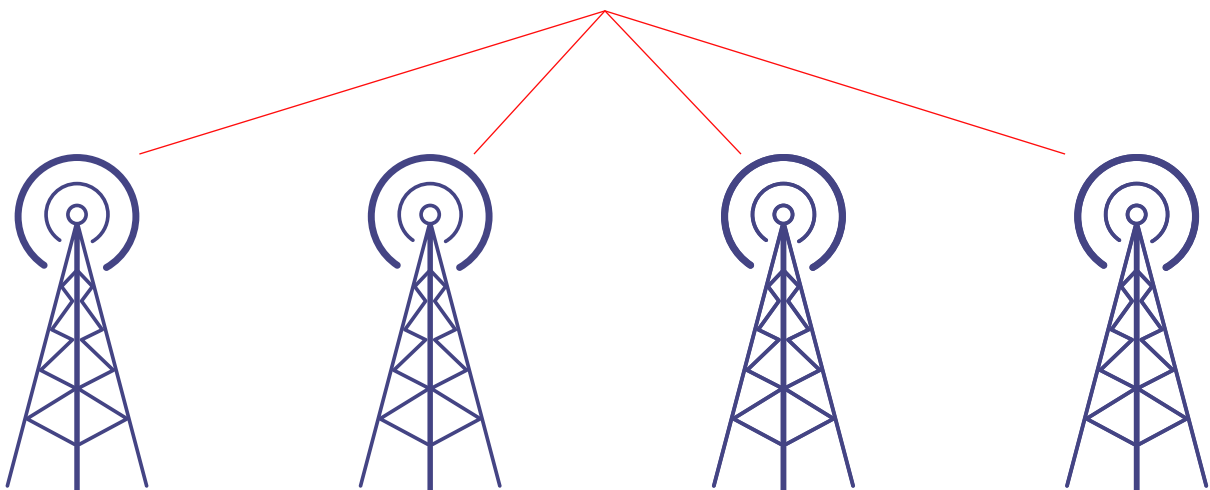

**Chrome and Firefox Recommended*

Data Center Infrastructure Management (DCIM)

AKCPro Server is a world class software for Data Center Infrastructure Management (DCIM). Avoid the complexity and cost of many popular DCIM software. AKCPro Server distills the essence of what DCIM should be to a simple, easy to use application.

Configure dashboards to display the data you need, with drill down mapping taking you from a data center wide to cabinet level view. A dedicated rack map shows smartRack sensors such as thermal maps and RFID Swing Handle lock information in a graphical display.

FEAUTURES

- Monitor your power train and calculate live PUE numbers
- Check power overhead when installing new devices
- Data center infrastructure monitoring and planning
- Building and rack level access control and management
- Integration to video security systems
- Thermal mapping of cabinets.

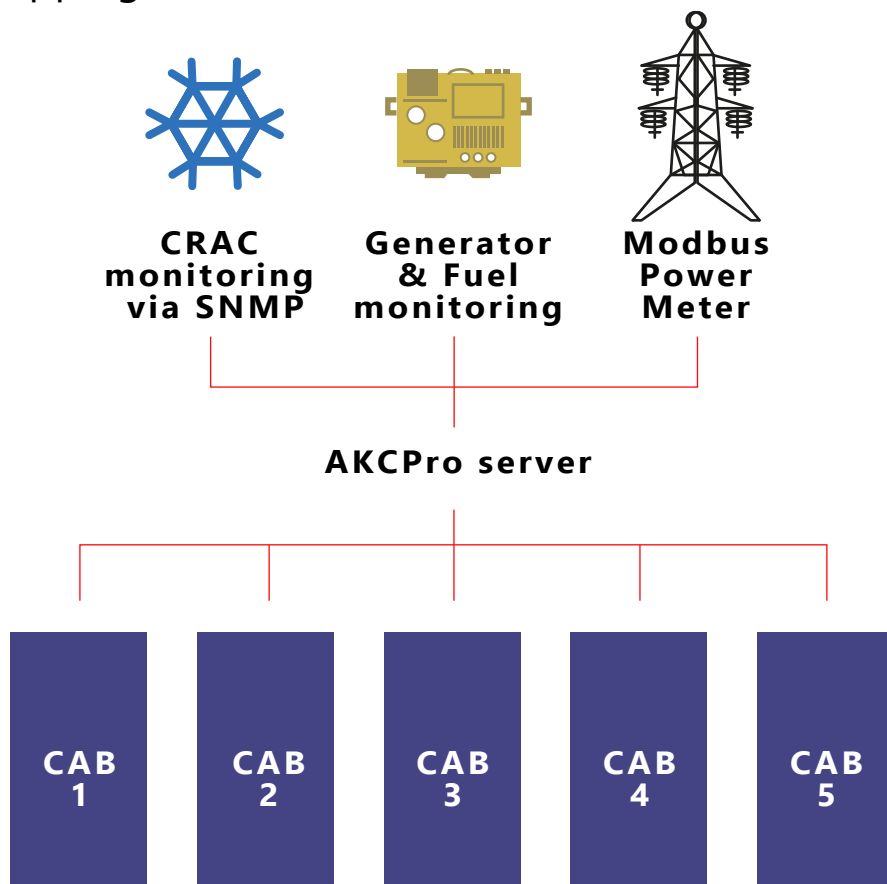

Monitor power consumption and thermal properties of your complete data center

Rack Mapping

Rack mapping is a graphical display in AKCPro Server that gives an accurate picture of your rack condition. With rack maps you can:

- View thermal map sensors front, rear and temperature differentials
- Track assets in your cabinets
- View the status of rack equipment
- View security status with RFID Swing Handle Cabinet Locks

Thermal maps sensors consist of 9 measurement points, top middle and bottom, plus the temperature differential between front and rear. Optional humidity front and rear is available. The sensors together with our graphical display of the data will aid greatly in identifying cabinet hot spots.

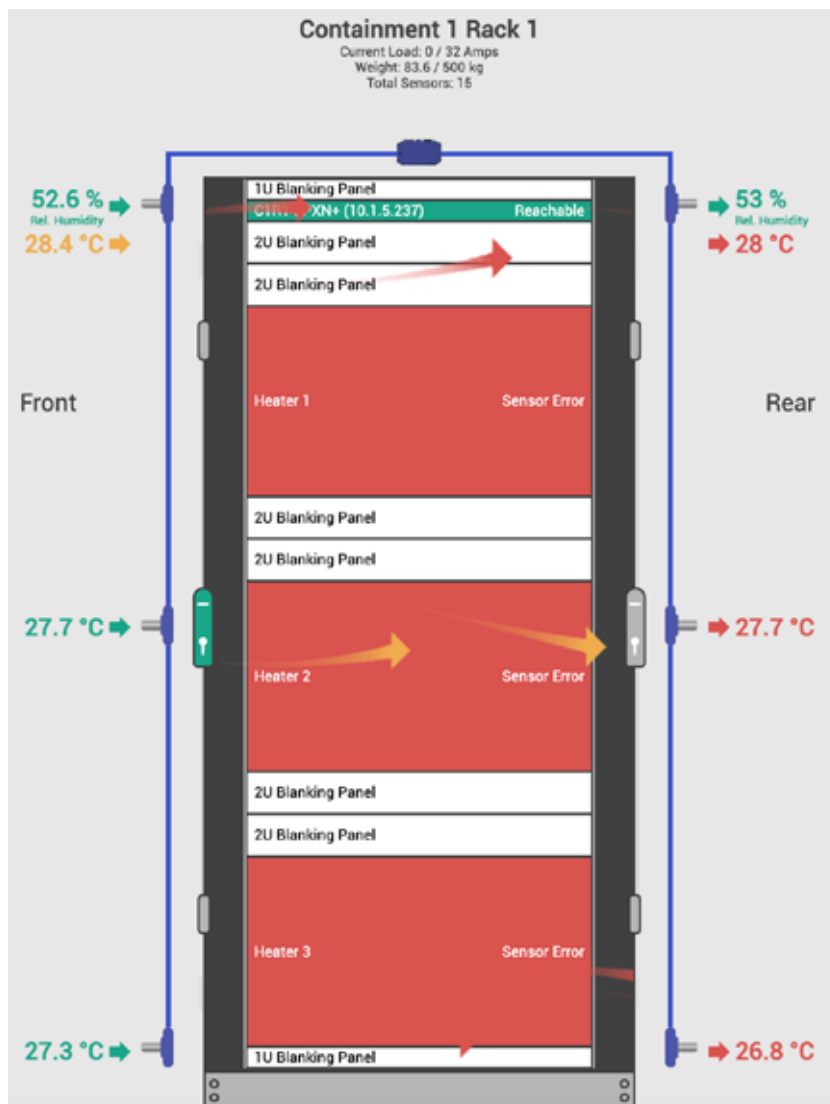

*Example of AKCPro server rack map view, with thermal map sensor and front to rear temperature differentials

Containment Mapping

As an extension to the rack mapping desktops, complete hot/cold aisle containment maps can be generated automatically from a data center floorplan. Create the floorplan by entering the number of cabinets and rows, and then assign the sensors to each rack. When drilling down the containment view will show a section through the aisle with rack maps, and the hot/cold aisle containment temperatures. Rack Map arrows indicate direction of airflow based on differential pressure readings, front to rear temperature differential status and air-flow speed.

With Containment Mapping you can :

- View thermal map sensors front, rear and temperature differentials
- Track assets in your cabinets
- View the status of rack equipment
- View security status with RFID Swing Handle Cabinet Locks
- View hot and cold aisle temperatures
- View differential pressures

Containment views are best used together with Wired or Wireless Cabinet Analysis Sensor which includes thermal mapping and differential pressure in one sensor.

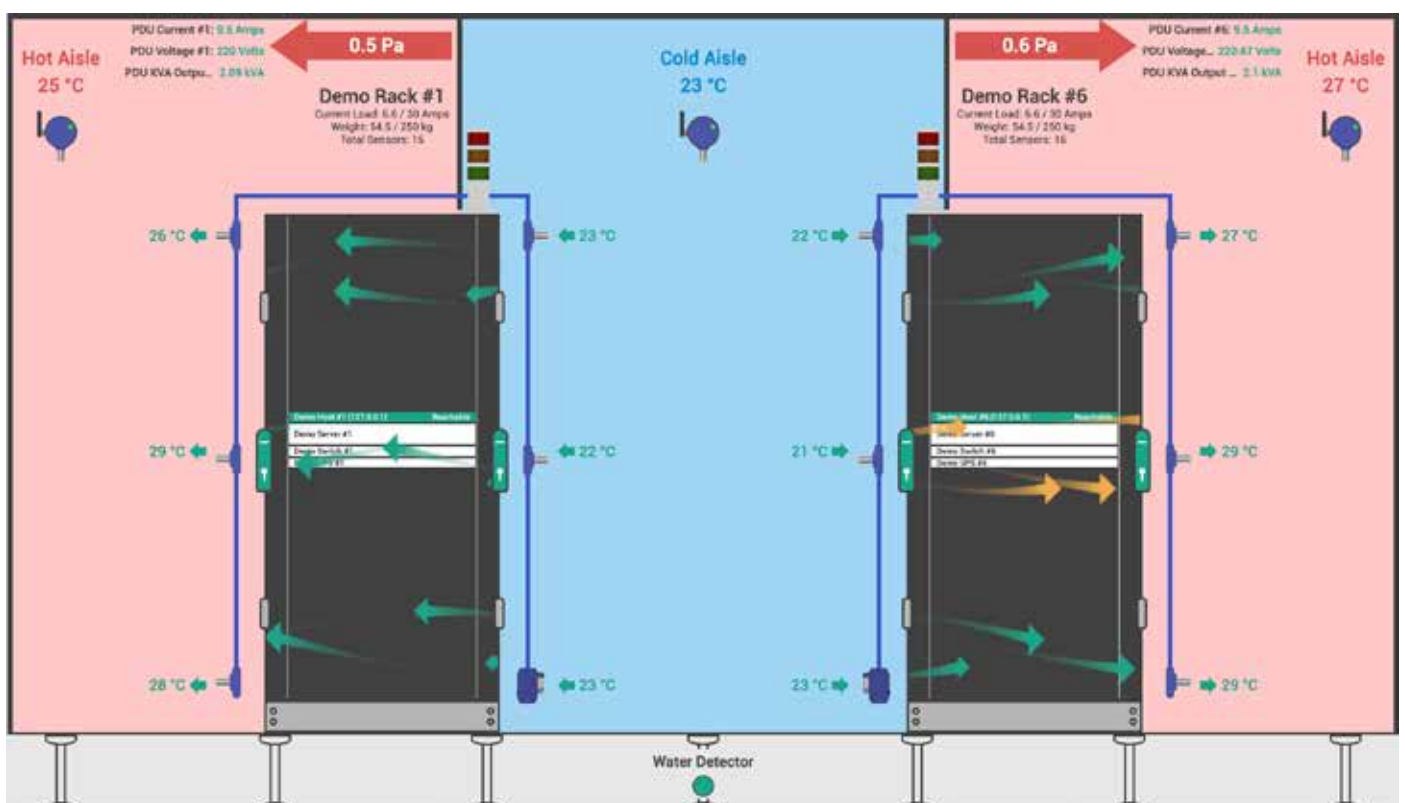

Data Center Mapping

AKCPro Server has built in data center floorplan drawing tools. Use the drawing tools to create a 2D representation of your data center. AKCPro Server will automatically convert the 2D drawing to 3D, giving you a complete virtual digital twin of your data center.

Position your sensors in 3D space, and view data center heat maps, cabinet thermal maps and pressure maps.

Easily layout your data center with auto generated cabinets for the number of aisles and cabinets you have. Add containment for either hot or cold aisles, raised access flooring and air return pathways, ducts and plenums.

Upgrade to the AKCP sensorCFD service, where the model is utilized together with multiple sensor data points from each cabinet to generate a sensor constrained CFD analysis of your data center.

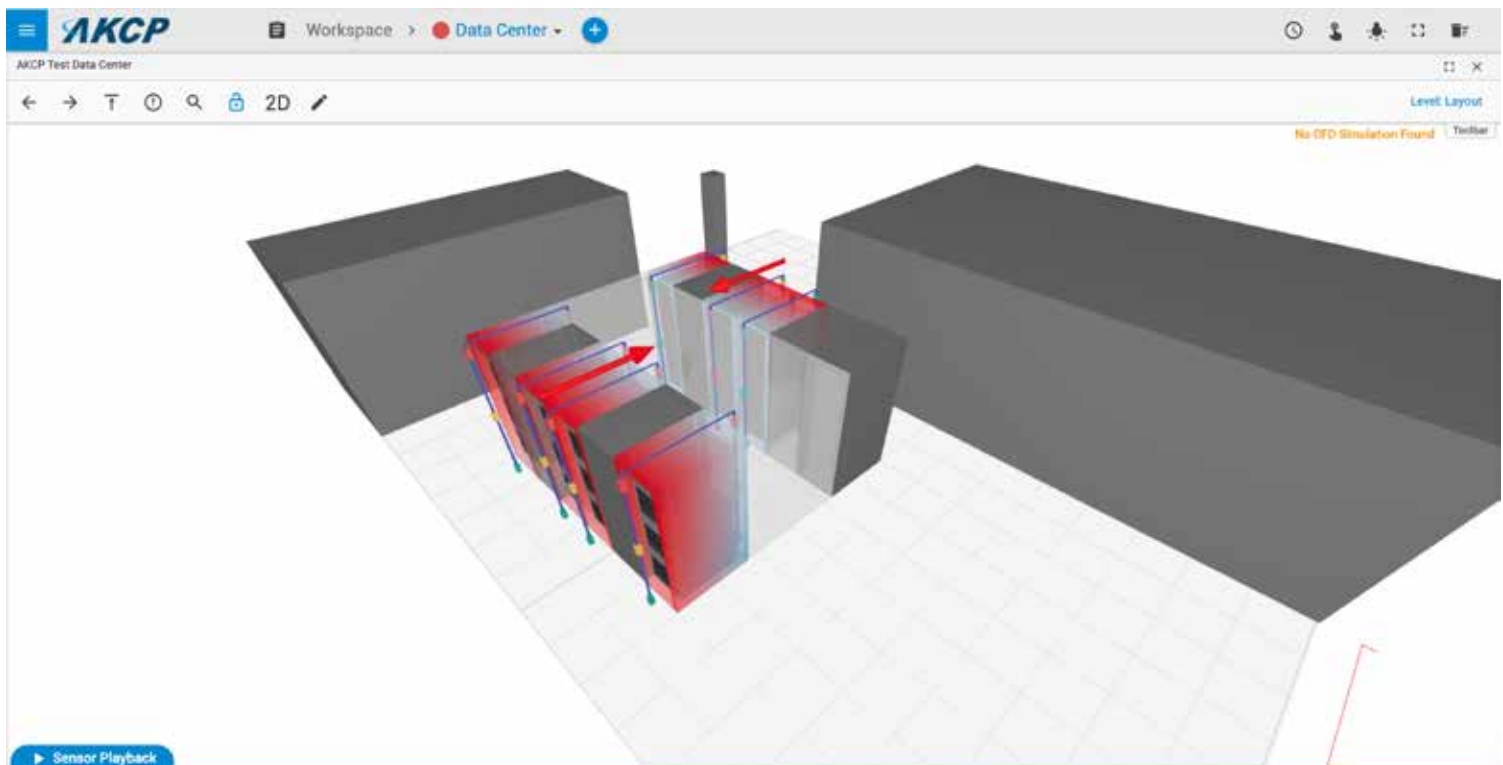

Asset Tracking

With asset tracking in AKCPro Server you can assign IT equipment to your rack maps, such as UPS, Network switches and servers. These assets have editable parameters for their weight and typical power consumption. A maximum weight and power load is defined for each rack so you can plan data center expansion, if there is sufficient weight or power overhead to add new equipment to a rack. Assets also have an attached history so you can track installation date, and record any maintenance history for a particular device. Virtual sensors, such as a ping sensor can be attached to an asset to check its network status.

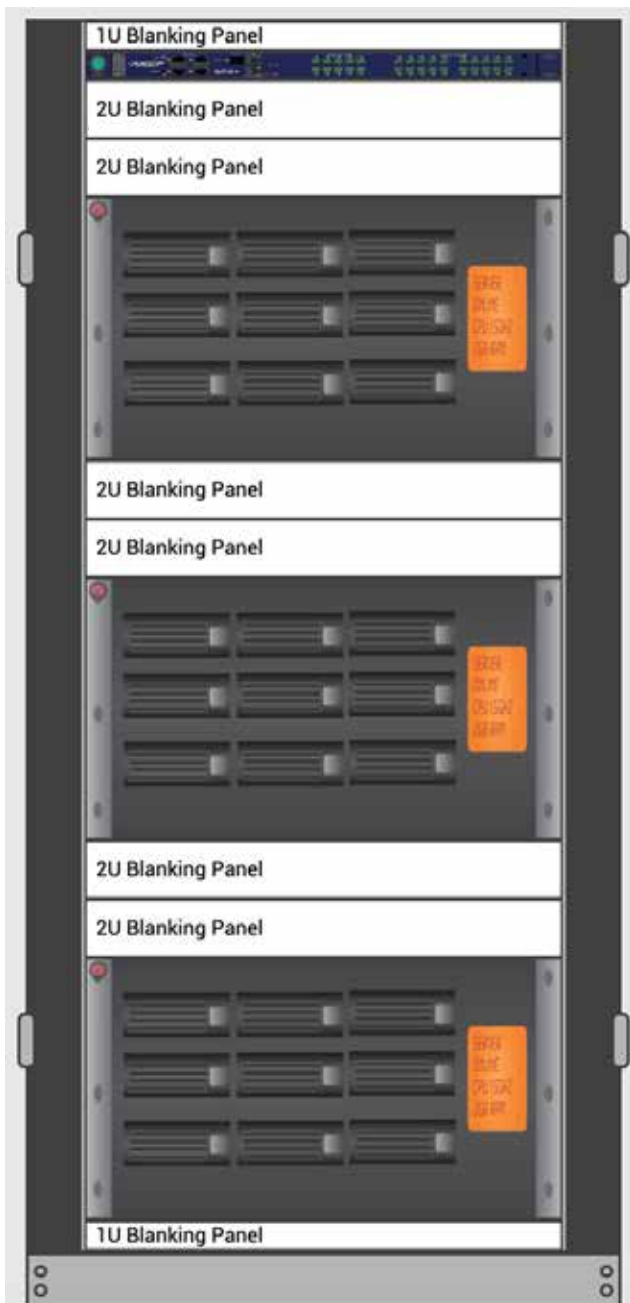

Edit Asset

- GENERAL
- EQUIPMENT
- LOCATION
- MAINTENANCE

Name: * Heater 1

Size (U): * 9 Weight (kg): 10 Type: * Standalone Server [MANAGE](#)

Current Consumption (Amps): 0 Max Current Consumption (Amps): Voltage input (Volt):

Power Phase: Single Phase Power Consumption (W): 9000 Power Source: Generator Power

Installed Date:

Link this asset with a sensor [SELECT A SENSOR](#) [CREATE A SENSOR](#)

C1R5 Heater 1 Current
C1R5 SPXN+ (10.1.5.233) [\[REDACTED\]](#)

[EXPORT](#) [CANCEL](#) [UPDATE](#)

Customized Desktops

AKCPro Server desktops are customized for each user to show the information relevant to them. Desktops display sensor data, gauges, drill down maps, cabinet rack maps, graphs and video feeds. Arrange the windows yourself, or choose from pre-determined layouts for easy setup.

Desktops show a live view, or can be switched to playback for review of historical data, with sensor events synchronized with video on the playback timeline.

Graphing Desktops



Desktops can be arranged with graphs to show historical sensor data. Desktops can be customized to combine graphs with other sensor data and status indicators and/or gauges.

Sensor Gauges

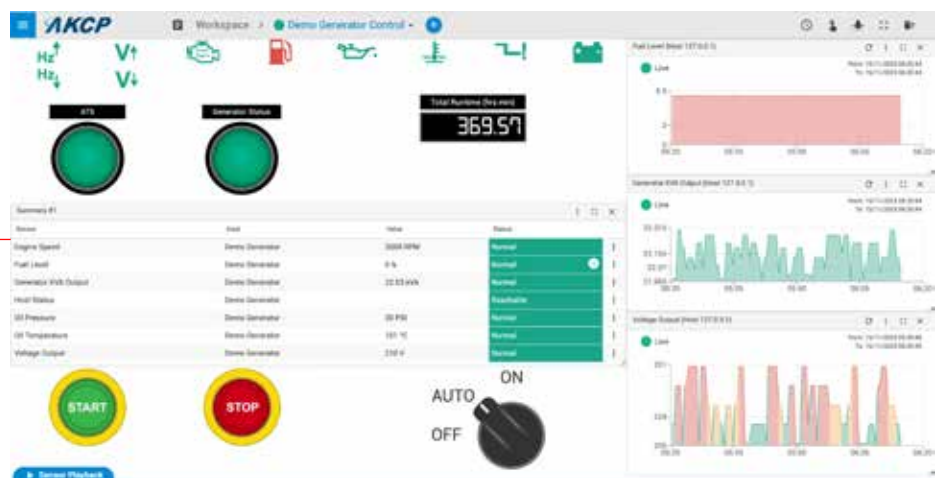

A selection of gauges can be used to display sensor data, specially designed with battery and engine monitoring in mind, they simulate the real world engine gauges.

Power Train Mapping

Data Center power train mapping for creating your layout, monitoring power utilization, capacity planning and simulating failures.

Create a digital twin of your data center power train, from power source, to backup power, breakers to individual appliances. Check for available power overhead on each circuit for planning expansion and capacity.

Calculate live PUE numbers and visualize instantly how changes you make to your operations impact your energy efficiency.

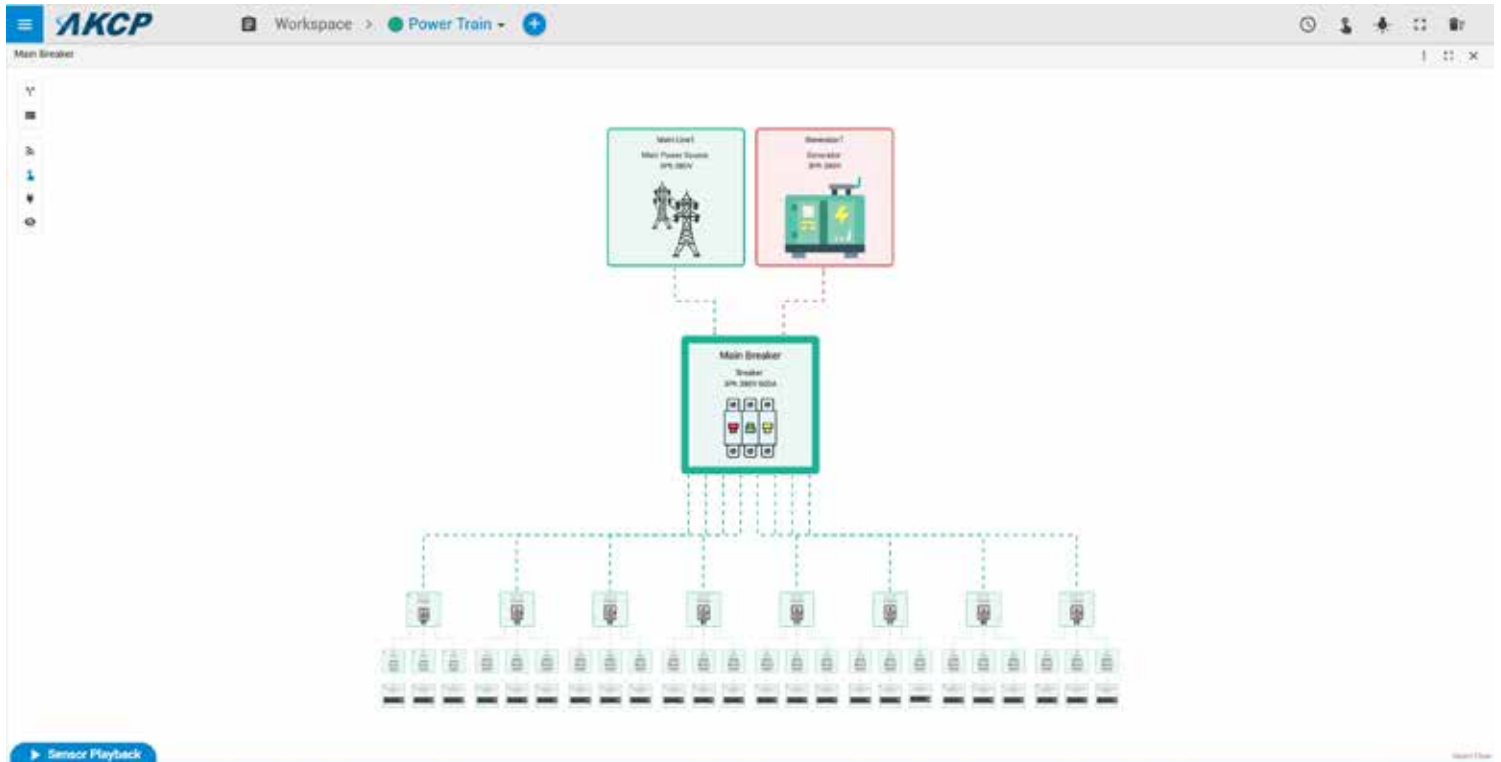

Video Integration

AKCPro Server integrates with IP based ONVIF compatible video cameras. Sensor events from AKCP and virtual sensors are synchronized in the playback window. This allows for easy visual reference of critical events or security breaches.

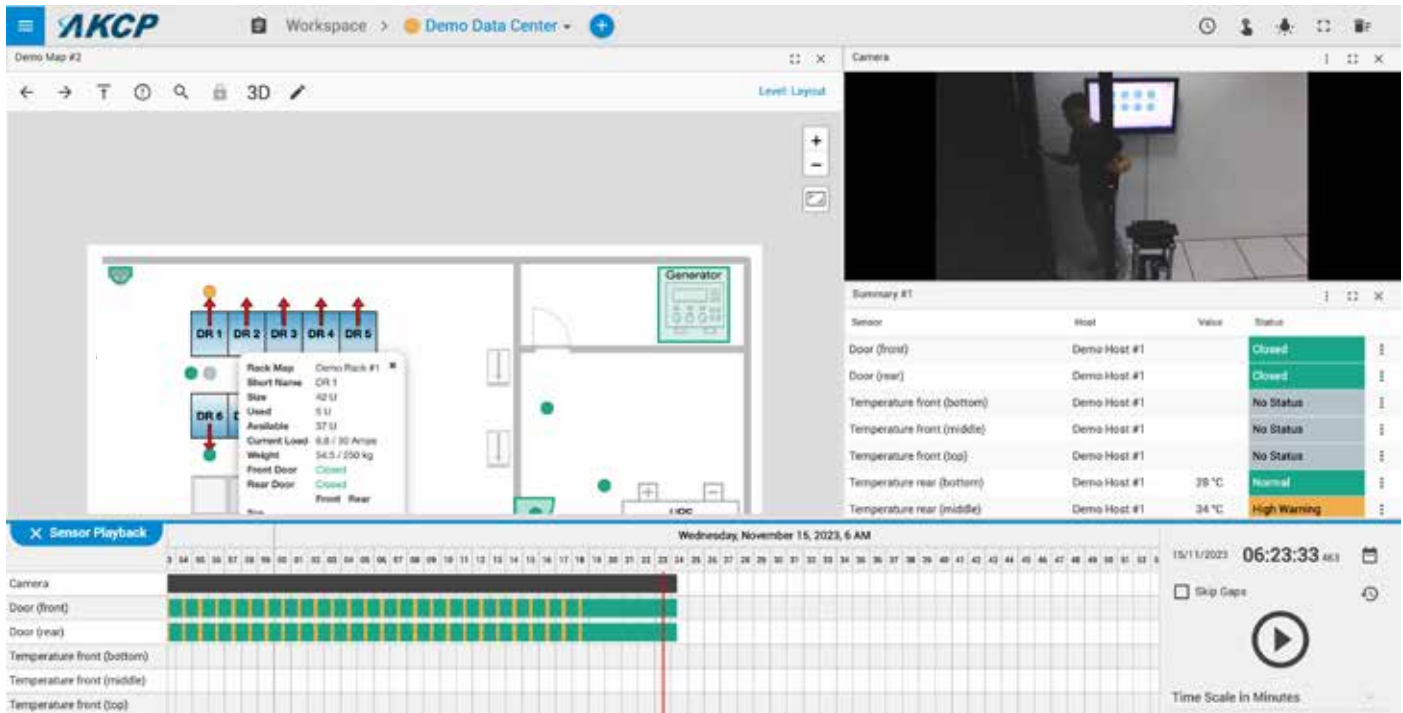

Desktops show live video, together with sensor status, and can be switched to playback, giving you an easy way to go back to specific sensor events and automatically recall and playback video from that time. Great for integration with access control systems, to have a visual reference for every access event.



Access Control

From AKCPro Server you can administer access control schedules and privileges, view access logs and reports on a per door, or per user basis. Know who accessed, what time and synchronize with video systems in the playback window to review actual video footage of the events.

Receive alerts if doors are left open, if unauthorized access attempts are made, setup anti passback features such as card expiration dates.

For the data center install AKCP RFID Swing Handle Cabinet Locks to protect your rack assets, and view the security status of the cabinets from the rack map desktops.

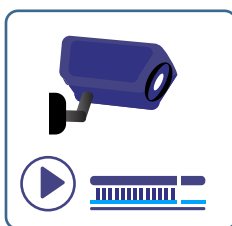
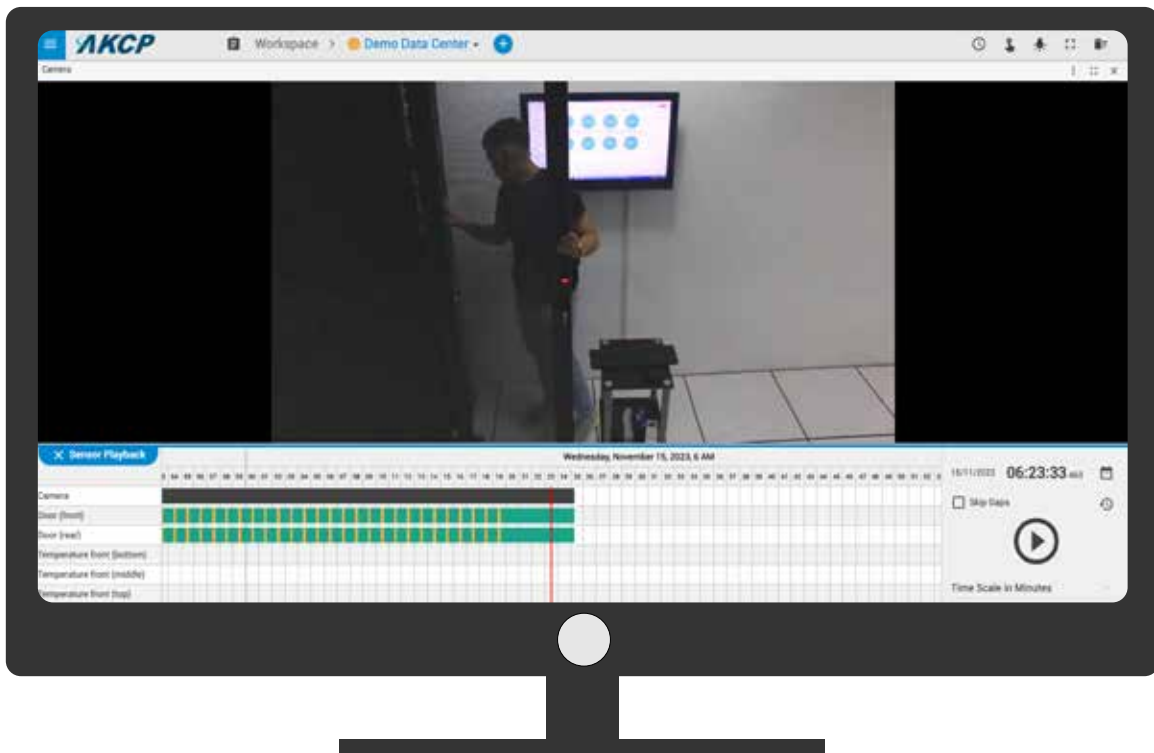

Tablet View

Use any Android or iOS tablet or cellphone to monitor your data center at ground level. No apps to install, just access using your google Chrome web browser. Now your technicians on the data center floor can be kept up to date and be alerted instantly to critical situations as they arise.

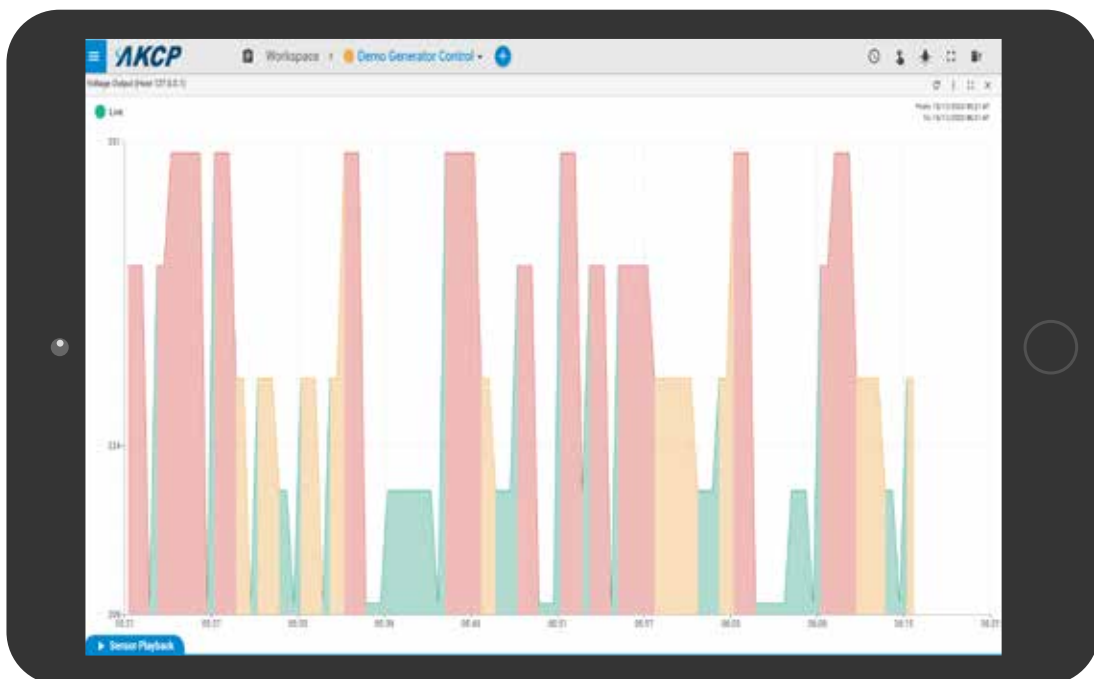
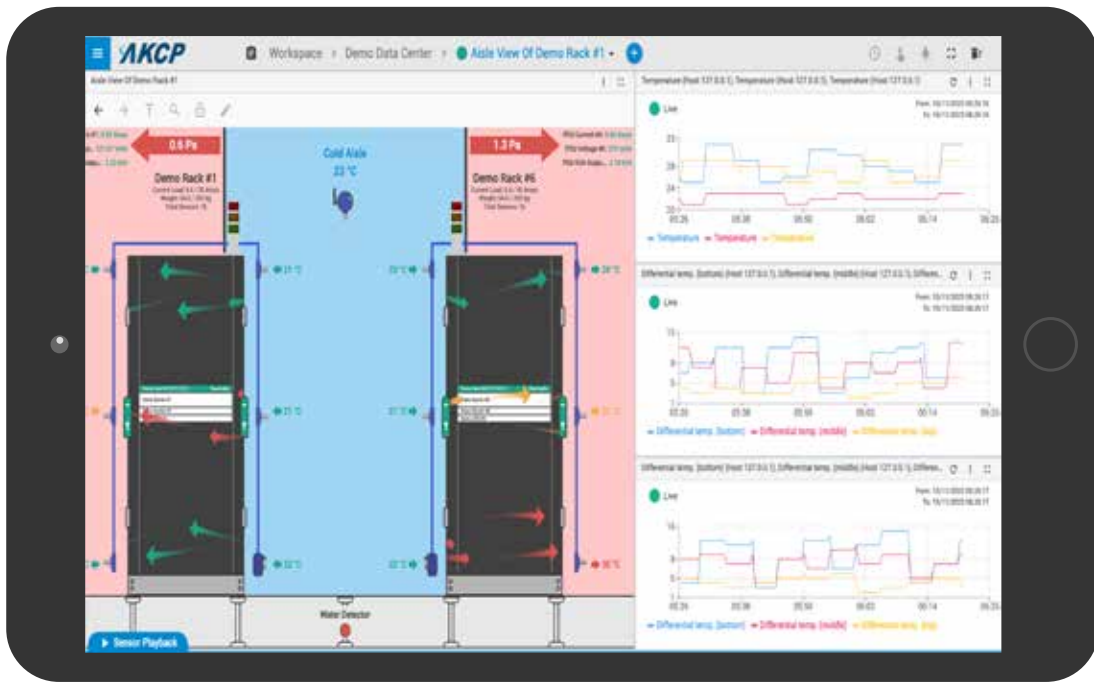

AKCP Cloud Access

Access to AKCP base units through firewalls.

The AKCP Cloud Access feature is available on the sensorProbe+ (SPX+ / SP2+) and the Wireless Gateway (WTG). It gives easy access to the units web interface without the need to setup port forwarding or open firewalls.



AKCP sensorCFD™

Sensor Constrained Computer Fluid Dynamics
sensorCFD™ was invented to address the spiraling energy costs, water usage, and concerns over the carbon footprint of data centers.

AKCP sensorCFD™ will identify problem areas in your data center that are costing you energy. With sensorCFD we can:

- Verify your data center cooling performance is in accordance with designed specifications
- Identify areas of air mixing that are costing your energy
- Spot overcooled racks, areas where CRAC setpoints can be safely increased
- Identify stranded capacity, and where server loads can be increased without additional cooling costs.

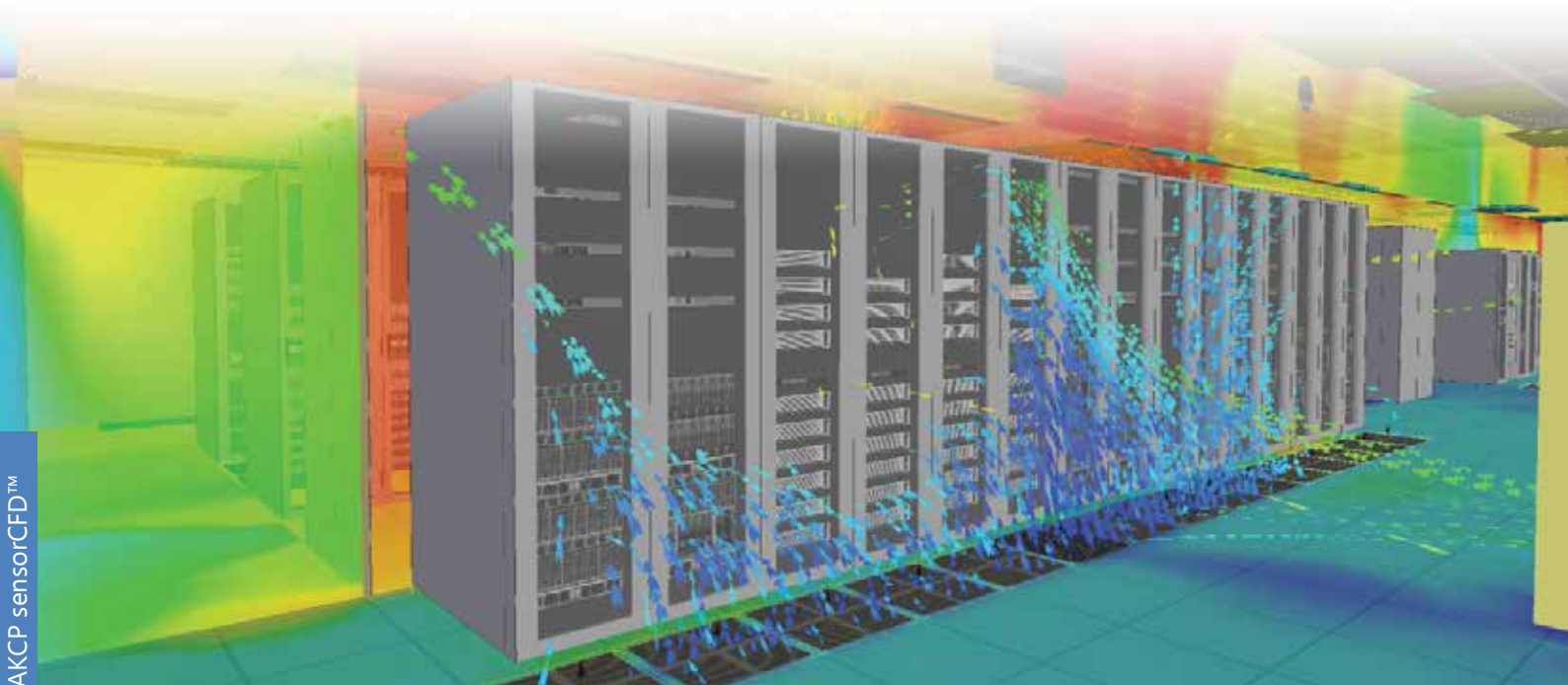

Traditional CFD vs. sensorCFD™?

Traditional CFD

Traditional Computer Fluid Dynamics (CFD) modeling is done during the data center design phase. Using arbitrary values for the rack capacity and cooling power, it makes many assumptions. But the data center energy use is not static, it is dynamic. Power loads for racks go up and down while cooling capacity adapts to the demands of the servers. Racks get moved, blanking panels left out, what was sealed containment may be no more.

With AKCP sensorCFD the simulation model is constrained by live sensor data to create an accurate CFD representation of actual data center performance.

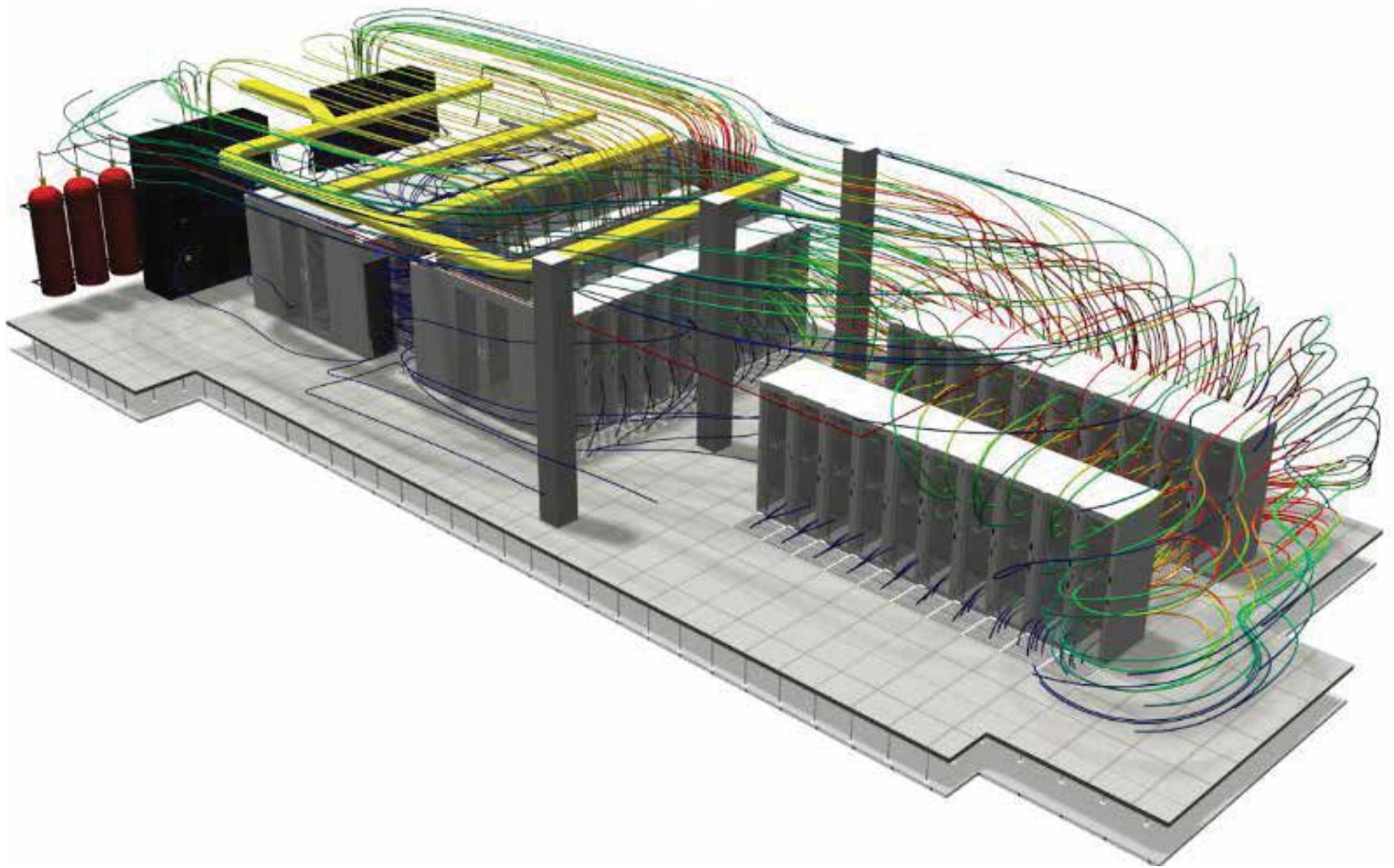

Typical data center CFD analysis performed during data center design phase.

Traditional CFD vs. sensorCFD™?

sensorCFD

AKCP sensors do more than simple monitoring and alerting when things go wrong. With 12 data points per rack covering temperature, humidity, ΔT , and rack power dissipation, we put that data to good use.

sensorCFD utilizes all the data gathered from the sensors on every rack, CRAC and plenum to produce a sensor constrained CFD analysis of the data center. Compare your performance to the original design, identify stranded capacity and areas of air mixing. Increase efficiency, lower carbon footprints and decrease operational expenses by fixing the identified problem areas.

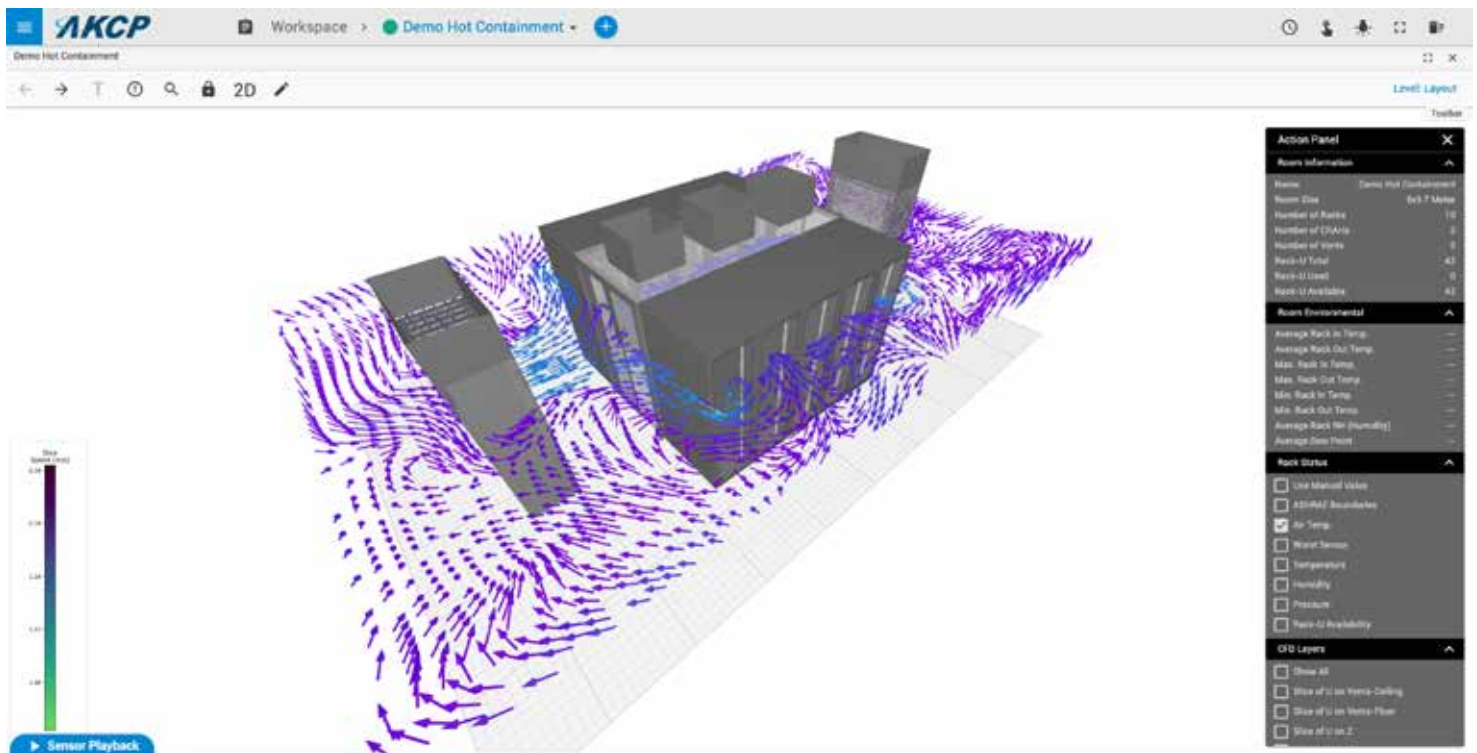

Example of data center airflow map generated by AKCP sensor constrained CFD analysis

The sensorCFD™ Rack Monitoring Solution

Complete rack monitoring system, with current metering, thermal mapping with ΔT , and Humidity all from a single sensor port.

Contactless Current Meter

Monitor current load to your cabinet. Check how close you are to tripping breakers, and calculate live PUE numbers. Power consumption of each rack is included in sensorCFD calculations.

Sensor Splitter Box

Interface box to connect thermal maps and current meter to a single sensor port on the SPX+. Connect up to 16 sensorCFD devices to a single SPX+

Cabinet Thermal Map

Check front and rear temperature and humidity at top, middle and bottom of cabinets, as well as front to rear temperature differential (ΔT). Data used for sensorCFD calculations.

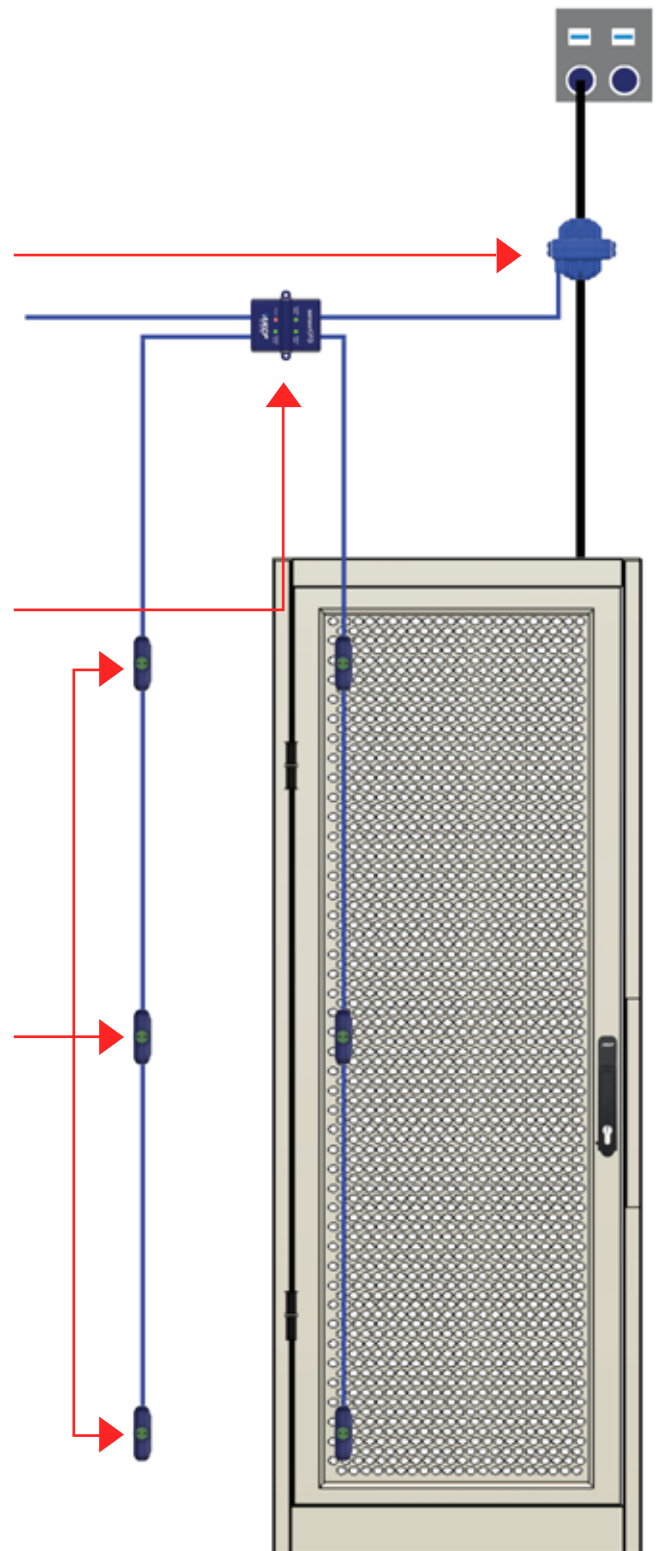

sensorCFD - The Model

Stage 1.

A detailed specification and floorplan of the current data center is produced. A 3D model of the data center is then created within sensorCFD. This includes all racks, raised flooring, ceiling plenums, CRACs, perforated floor tiles and containment.

Sensors are installed in the data center and the system collects data. The resulting sensor data is used to create a CFD model and to verify that the model is accurate.

Wherever sensors are unavailable, static data may be manually added.

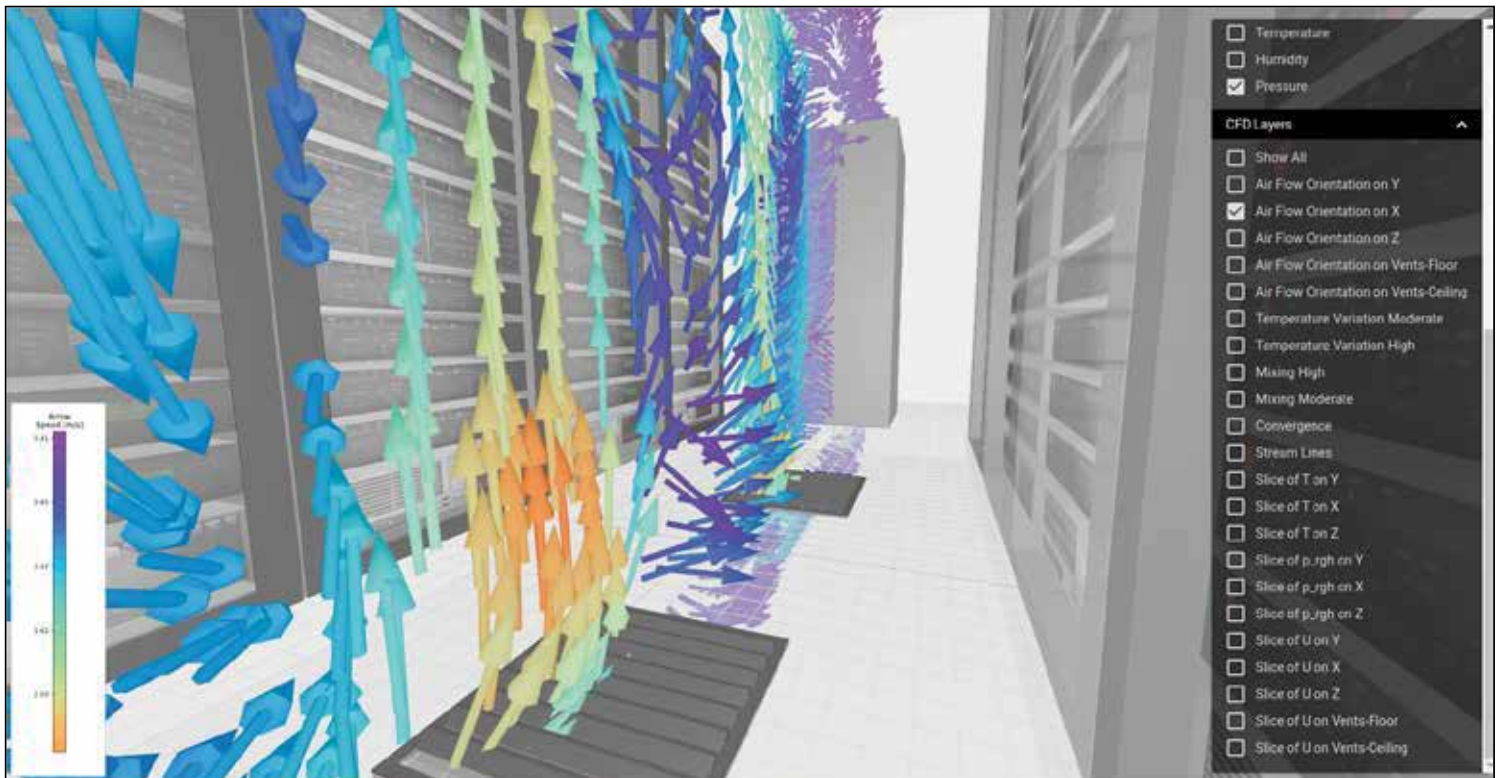

sensorCFD - Improved Efficiency

Stage 2.

Improvements are made by the customer in accordance with the analysis of the sensorCFD simulations and graphic reports. The system continues to collect data, creating graphic reports allowing the user to see the effect of his changes upon the data center and any further improvements that could be made.

At this stage the data center should be running efficiently and with reduced energy costs, reduced carbon footprint and potentially could increase capacity without additional cooling being required.

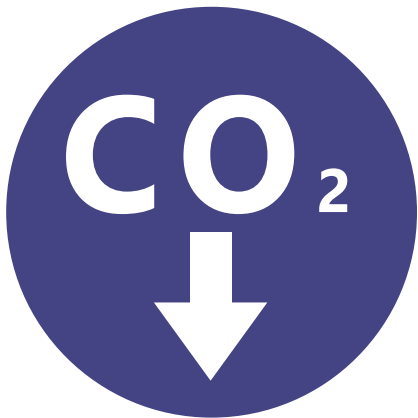

sensorCFD - Sensors as a Service

Stage 3.

Now that the data center is running at optimum efficiency, to ensure that it maintains that efficiency, the sensors are left in place to continually monitor and alert to changes. Changes to the data center such as moving a rack, installing new equipment are analyzed for its effect on data center operation.

Running the data center at optimal efficiency carries risk, the hotter you allow the air input to racks, the lower your energy costs, but the less margin for error. Only through the detailed sensor analysis that the AKCP sensorCFD provides can you maintain peak energy savings.

sensorCFD is integrated into AKCPro software, so you get sensors, CFD and monitoring all in one integrated package.



sensorCFD thermal map and contactless current meter for each rack

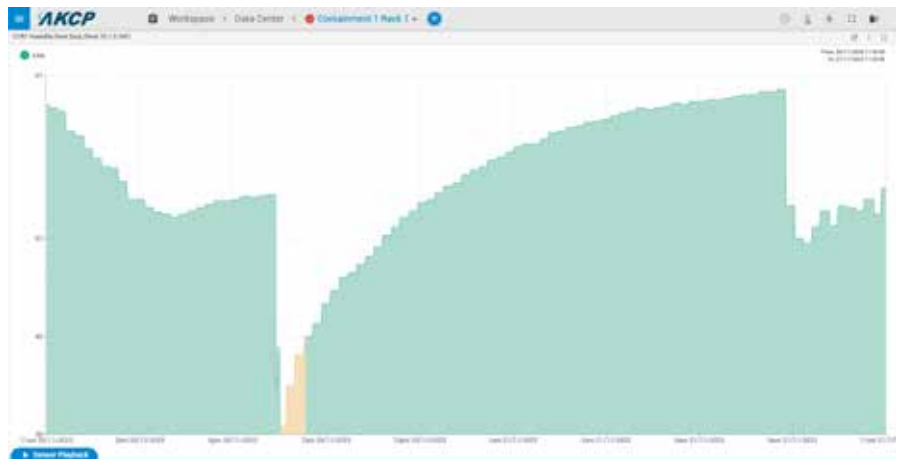

Graphing of sensor data with customizable desktops

Environmental Sensors

Sensor for monitoring temperature, humidity, water leaks and airflow. Specialist sensors such as thermocouples can cope with extreme temperatures, and thermal map sensors will monitor and map the air temperature at the top, middle and bottom of your computer cabinets.

Connect the sensor to a compatible AKCP base unit, and you have an SNMP enabled monitoring system with it's own web interface or integrate to third party monitoring software. For a tightly integrated solution choose our central management software, AKCPro Server.



Airflow Sensor



Cabinet Analysis Sensor



**Temperature and Humidity
(Water resistant)**



Temperature Sensors



Spot Water Sensor



Rope Water Sensor



Thermal Map Sensor



J-K Thermocouple

Thermal Map Sensor (THMS-V2 / CTHMS-V2)

Pre-wired for easy installation on your cabinet. Placed at the top, middle and bottom - front and rear of the cabinet. This configuration of sensors gives monitoring of the air intake and exhaust temperatures of your cabinet, and the temperature differential from the front to the rear.



Monitor temperature differentials in your cabinet

An interface box allows you to plugin a single string (THMS) or two strings (CTHMS). When a single string is used only the front or rear, top middle and bottom temperature values are monitored. When two strings are used both front and rear, top middle and bottom are monitored and T values are calculated.

Thermal Map sensors are compatible with all sensorProbe+ base units. Sensors are provided with double sided VHB tape for mounting. Optional magnetic re-positionable mounting kit is available.

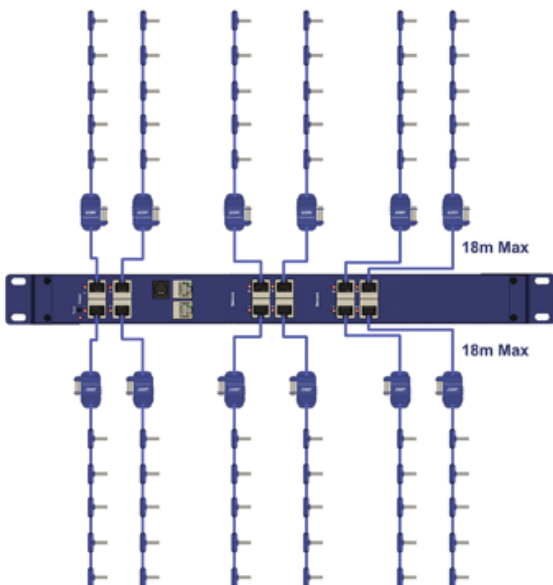

Thermal map sensors connect to any AKCP sensorProbe+ base units. Extendable up to a maximum of 18 meters cable length, you can monitor multiple cabinets from a single IP address. The maximum number of thermal maps on a single SPX+ is 16.

THMS-V2 / CTHMS-V2



Thermal maps can be added to rack map views in AKCPro Server. Animated arrows show the temperature differential from the front to rear of the cabinet as well as the individual sensor values at the front, rear, top, middle and bottom of the cabinet. 3D heatmap visualization of your data center allows you to quickly identify hotspots or areas being over cooled.

Cabinet rack map displaying thermal maps in AKCPro Server

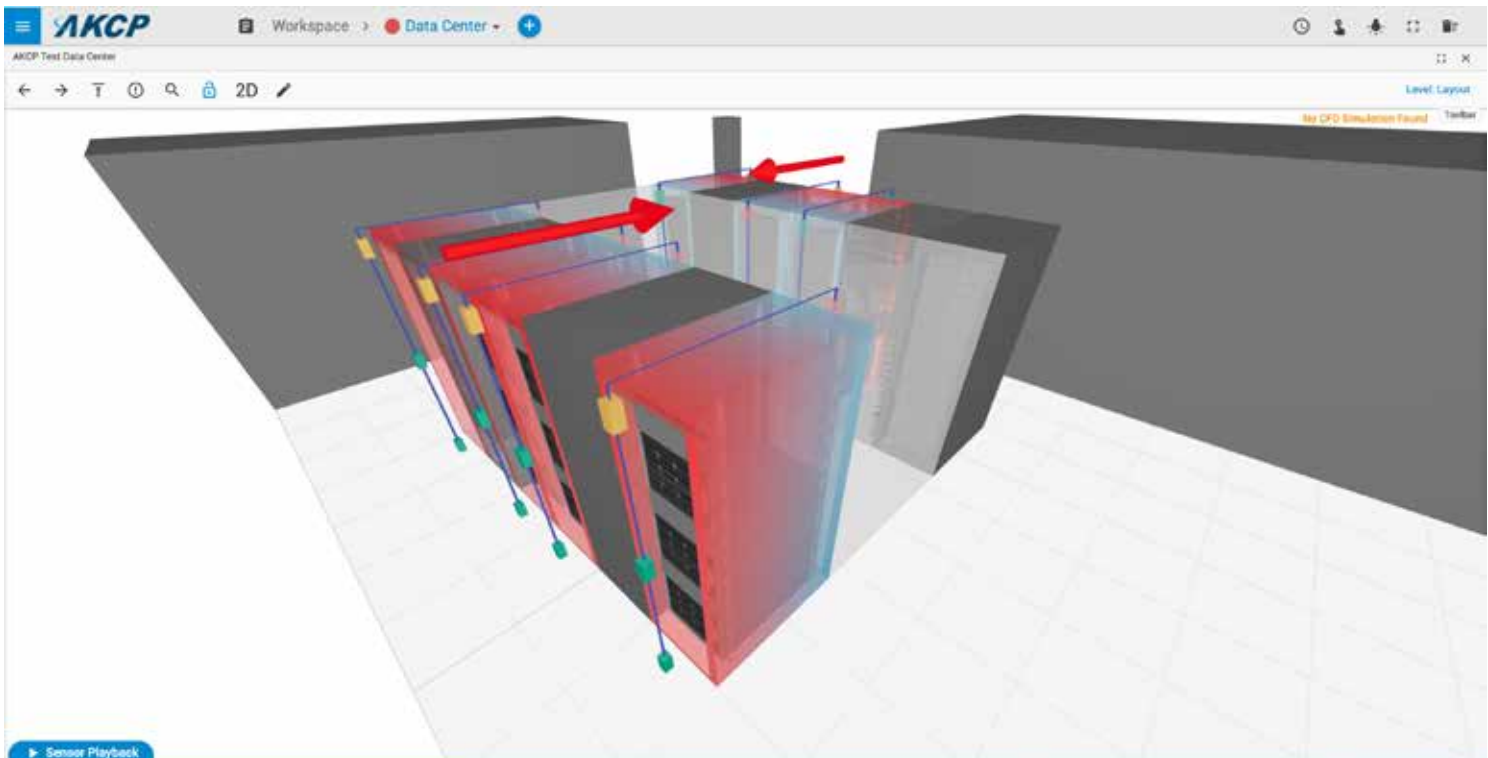

3D Heatmaps displayed in AKCPro Server

THMS-V2 / CTHMS-V2 - Technical Specifications

Dual Temperature	
Measurement Range	-40°C to +75°C -40°F to +167°F
Measurement Resolution	0.1°C increments 0.2°F increments
Measurement Accuracy	Maximum ±0.3 at -40°C, minimum ±0.3 at +25°C and ±0.3 at +75°C Maximum ±0.6 at -40°F, minimum ±0.6 at +25°C and ±0.6 at +167°F
Dual Humidity	
Measurement range	0 to 100% Relative humidity
Resolution	1%RH increments, 0.01%RH sensor reading
Accuracy at	25°C ±2%RH
Single Temperature	
Measurement Range	-40°C to +75°C -40°F to +167°F
Measurement Resolution	0.1°C increments 0.2°F increments
Measurement Accuracy	±0.5°C accuracy from -10°C to +75°C ±0.9°F accuracy from +14°F to +167°F
Interface	
Communications cable	RJ-45 jack to sensor using UTP CAT5e/6 cable
Power source	Powered by the sensorProbe+ family units. No additional power needed
Power Consumption	Typical 75 mWatt, 15 mA
Maximum Cable Length	Sensor can be extended from the RJ-45 Intelligent Sensor ports on the base units up to 60 feet, or 18 meters using standard CAT5/6 LAN cable
	sensorProbe+ units auto detects the presence of the Cabinet Thermal Map Sensor
Dimension	75 x 55 x 27 mm
Mounting	VHB Tape, Magnetic (optional)
Components	Manufactured using highly integrated, low power surface mount technology to ensure long term reliability.
Operating Environment	Temperature : Min. -35° C – Max.80° C Humidity: Min. 20% – Max. 80% (Non-Condensing)
Sensor count	THMS-V2 : 4 CTHMS-V2 : 11

THMS-V2 - Technical Drawing

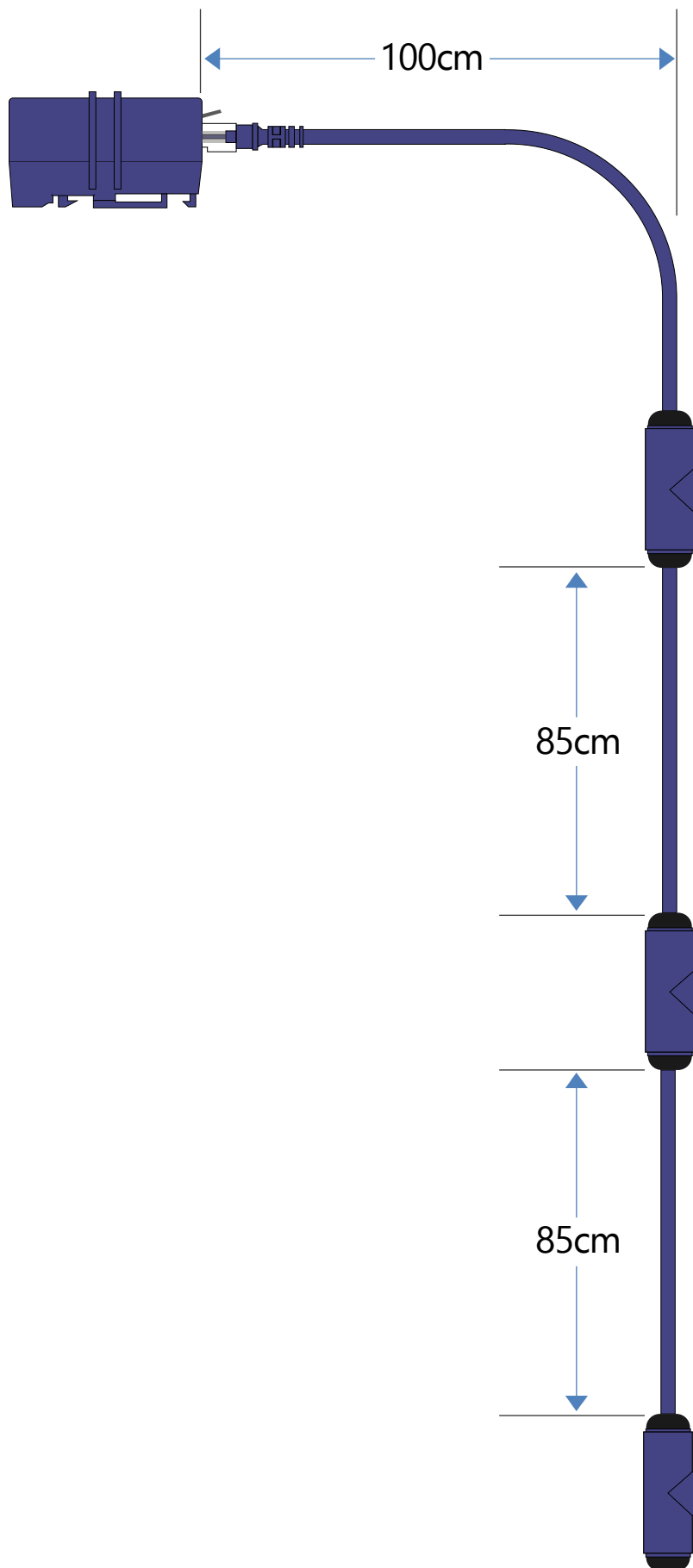

CTHMS-V2 - Technical Drawing

Cabinet Thermal Map Sensor string

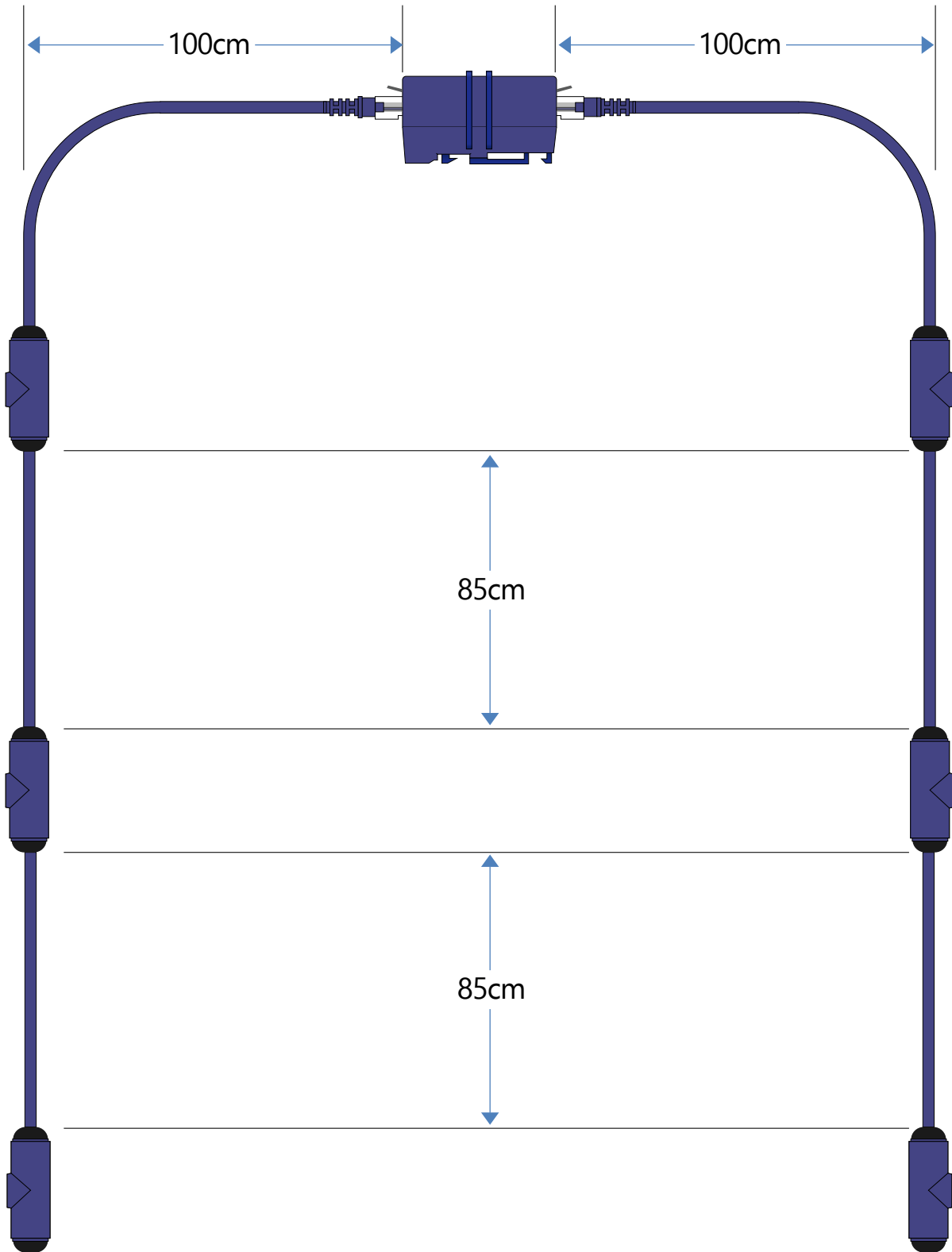

Cabinet Analysis Sensor (CAS)

The cabinet analysis sensor combines differential pressure and cabinet thermal maps into one smart sensor. Sensors include :

String of 6x Temp sensors and 2x Humidity for cabinet front and rear temperatures with ΔT calculation of front and rear temperature differentials.

Differential pressure sensor, check for proper pressure differential between front and rear. Ideal for hot/cold aisle containment to ensure proper airflow.

AKCPro Server Rack Map View Use the CAS with dedicated rack map views on AKCPro Server. A visual representation of your cabinet, with airflow, front and rear temperatures, temperature differentials and differential pressure. Add swing handle locks, LCD display and sensor status light for a complete Rack+ solution.

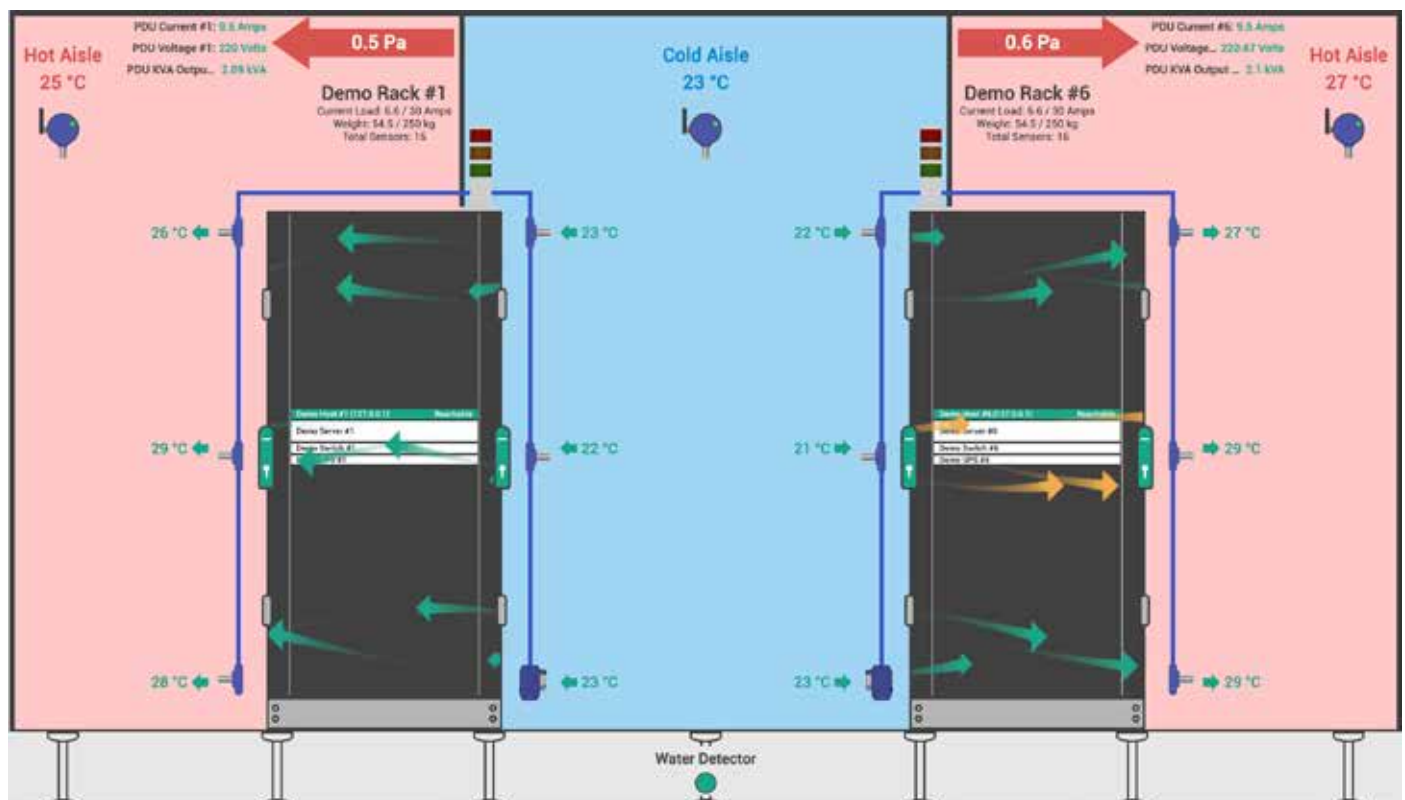

CAS - Technical Specifications

Environment monitoring	
Temperature	6x Temperature sensor values 3x Differential Temperature sensor values -40°C to +75°C
Measurement Range	-40°C to +75°C -40°F to +167°F
Measurement Resolution	0.1°C increments 0.2°F increments
Measurement Accuracy	Maximum ±0.3 at -40°C, minimum ±0.3 at +25°C and ±0.3 at +75°C Maximum ±0.6 at -40°F, minimum ±0.6 at +25°C and ±0.6 at +167°F
Humidity	2x Humidity sensor values
Measurement range	0 to 100% Relative humidity
Resolution	1%RH increments, 0.01%RH sensor reading
Accuracy at	25°C ±2%RH
Differential Pressure	1x Differential Pressure value
Measurement Range	± 125 Pa (±0.5 inH2O / ±1.25 mbar)
Resolution	0.01 Pa increments
Accuracy at	25°C ±0.5%
Interface	
Communications cable	RJ-45 jack to sensor using UTP CAT5e/6 cable
Power source	Powered by the sensorProbe+ family units. No additional power needed
Power Consumption	Typical 250 mWatt, 50 mA
Maximum Cable Length	The CAS sensor can be extended from the RJ-45 Intelligent Sensor ports on the base units up to 60 feet, or 18 meters using standard CAT5/6 LAN cable
Dimension	75 x 55 x 27 mm
Mounting	Desktop, Wallmount, Din rail, Magnetic
Components	Manufactured using highly integrated, low power surface mount technology to ensure long term reliability.
Operating Environment	Temperature : Min. -35° C – Max.80° C Humidity: Min. 20% – Max. 80% (Non-Condensing)
Important Note	- The Cabinet Thermal Map sensor is only compatible with the sensorProbe+ platform units. - When plugging the first time or after upgrading a sensorProbe+ unit, the sensor firmware might be upgraded by the unit and not be available right away. - On the sensorProbeX+, the sensor firmware can be upgraded only on the main module sensor ports
Sensor count	12

CAS - Technical Drawing

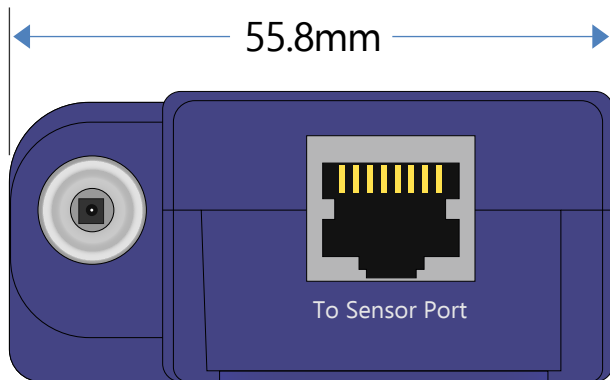
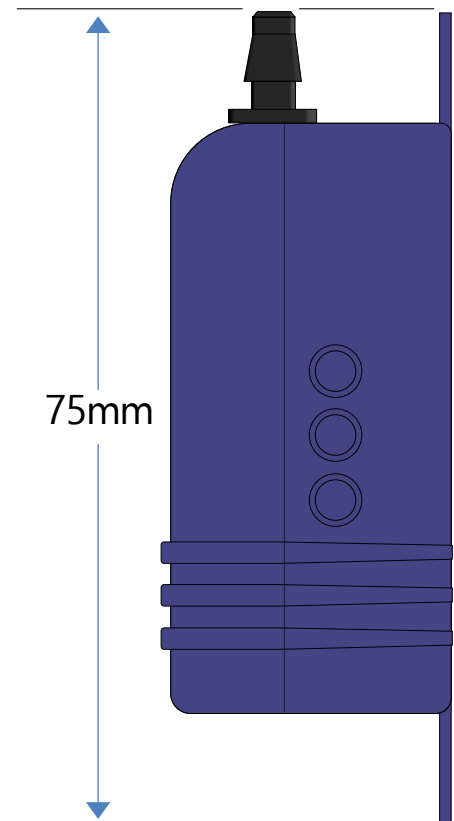
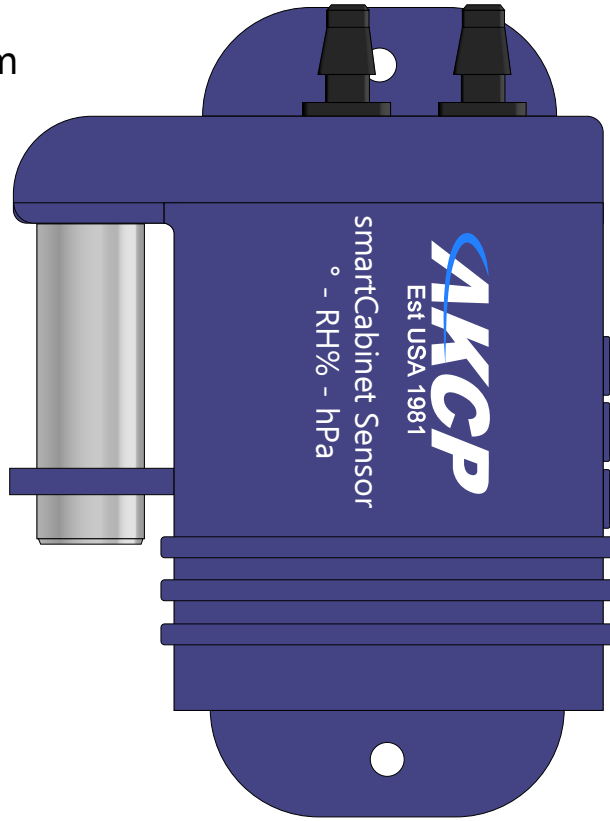
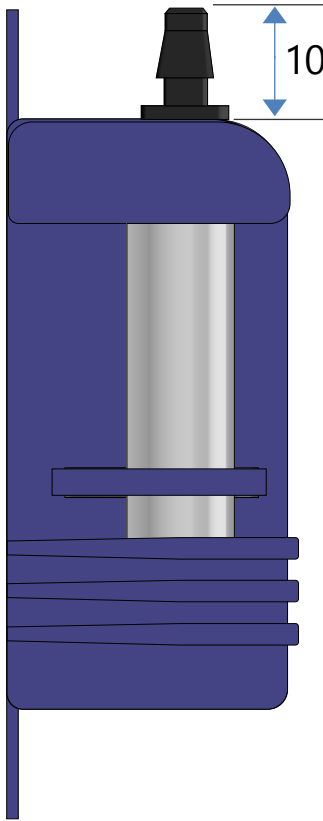
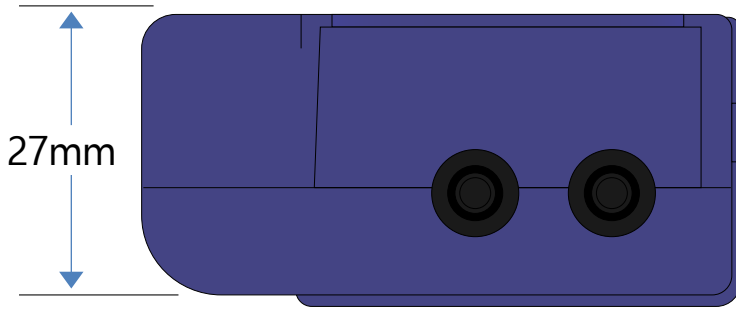

Temperature Sensors (TMP00-NIST2 / TMP01-NIST2)

If you're spending money for monitoring, wouldn't you want to know the sensors are calibrated?

2 NIST certified, calibrated temperature sensors are compared once a second for accuracy. (NIST2)

The NIST2 sensors feature a built in calibration check. Each unit has 2x NIST calibrated and certified temperature sensors. The primary sensor value is checked by the secondary sensor, and if we detect a range of greater than the stated accuracy we will alert that the sensor is out of calibration.

This makes these sensors ideal for situations where a high degree of accuracy is required and assurance of the calibration state



TMP00-NIST2

The sensor can be extended up to 50m (165ft) using standard CAT5 cable.



TMP01-NIST2

Fixed length sensor with 1ft cable.

Temperature Sensors (TMP00-NIST3 / TMP01-NIST3)

Calibration Check with Failover

3 NIST certified, calibrated temperature sensors are compared once a second for accuracy, with backup if pair is out of calibration (NIST3).

The NIST3 sensors feature a built in calibration check. 3 NIST calibrated sensors working in 3 pairs. The primary sensor value is checked by the secondary sensor, and if we detect a range of greater than the stated accuracy we will alert that the sensor is out of calibration. The sensor will then automatically fail-over and continue monitoring with a seamless graph of data.

Suitable for situations where a high accuracy, calibrated sensors are needed, with backup for critical monitoring applications.



TMP00-NIST3

Just like the TMP00, this sensor can be extended up to 50m (165ft) using standard CAT5 cable.



TMP01-NIST3

Fixed length sensor with 1ft cable

Temperature Sensors (TMPWxx-xxmm)

TMPWxx

Waterproof temperature sensor* with extended metal tube. Available in a variety of cable lengths and in either the standard tube or a choice of two additional tube lengths, either 50mm or 100mm. Custom lengths can be ordered with code TMPWxx / TMPWxx-50mm / TMPWxx-100mm where xx is replaced by the cable length in feet.



TMPW15-100mm



TMPW15-50mm

**Water proof up to length of metal tube*

TMP00-NIST2 / NIST3 / TMPWxx - Technical Specifications

Temperature	
Measurement Range	-55°C to +75°C -67°F to +167°F
Measurement Resolution	securityProbe and sensorProbe+ series 0.1°C increments 0.2°F increments sensorProbe series 1°C increments 1°F increments
Measurement Accuracy	sensorProbe+ series and securityProbe series ±0.2°C accuracy from -10°C to +75°C ±0.5°F accuracy from +14°F to +167°F sensorProbe series ±1°C accuracy from -10°C to +75°C ±1°F accuracy from +14°F to +167°F
Calibration	NIST traceable Calibration Certificate (TMPxx-NIST2 / 3) Built in calibration check, alerts when sensor needs re-calibration NIST3 with calibration check and failover
Interface	
Communications cable	RJ-45 jack to sensor using UTP CAT5e/6 cable
Power source	Powered by the base units. No additional power needed
Power Consumption	Typical 7.25mWatt, 1.45mA
Maximum Cable Length	TMP00-NIST2/3 - 165ft (50meters) with low capacitance shielded UTP cable TMP01-NIST2/3 - 165ft (50 meters)
Sensor Type	Semiconductor, microprocessor controlled
Dimensions	56 x 55 x 33.3 mm
Mounting	DIN rail mounting Screw mounting
Sensor count (TMPxx)	1
Sensor count (TMPxx-NIST2 / 4)	3
Important Note	The fixed one foot type or TMP01 are not designed to be extended. If you need to extend these sensors then you need to use the TMP00 (remote type). We also do not recommend you trying to connect any of our AKCP sensors including the temperature and dual temp humidity sensors though patch panels or using the RJ-45 couplers to extend them. Please see the temperature sensors product manual or FAQ in our knowledge base for more details regarding this.
Compatibility	NIST2 compatible with sensorProbe+ series and securityProbe / NIST3 sensorProbe+ only

TMP00 / TMP01-NIST2 / NIST3 - Technical Drawing

TMP00 - Extendable Temperature Sensor



TMP01 - 1ft Temperature Sensor

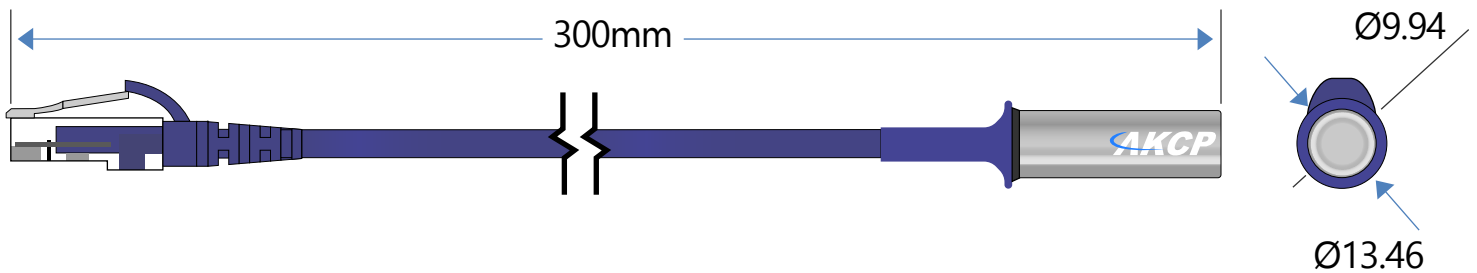

TMPW15 - Technical Drawing

TMPW15-50mm- Waterproof Temperature Sensor with 50mm tube

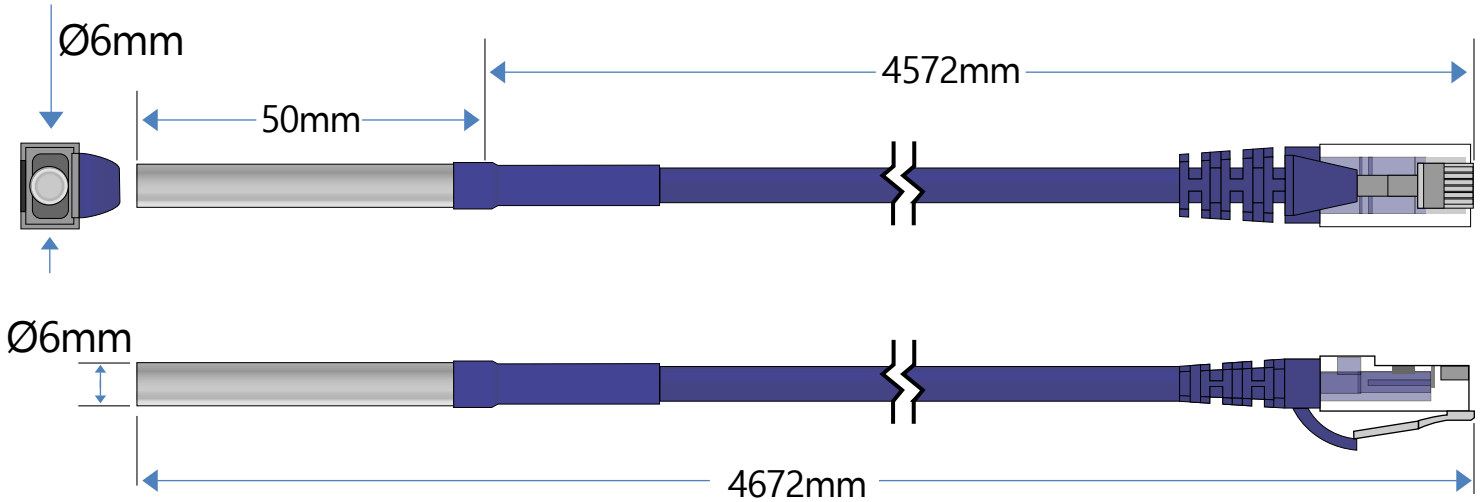

TMPW15-100mm- Waterproof Temperature Sensor with 100mm tube

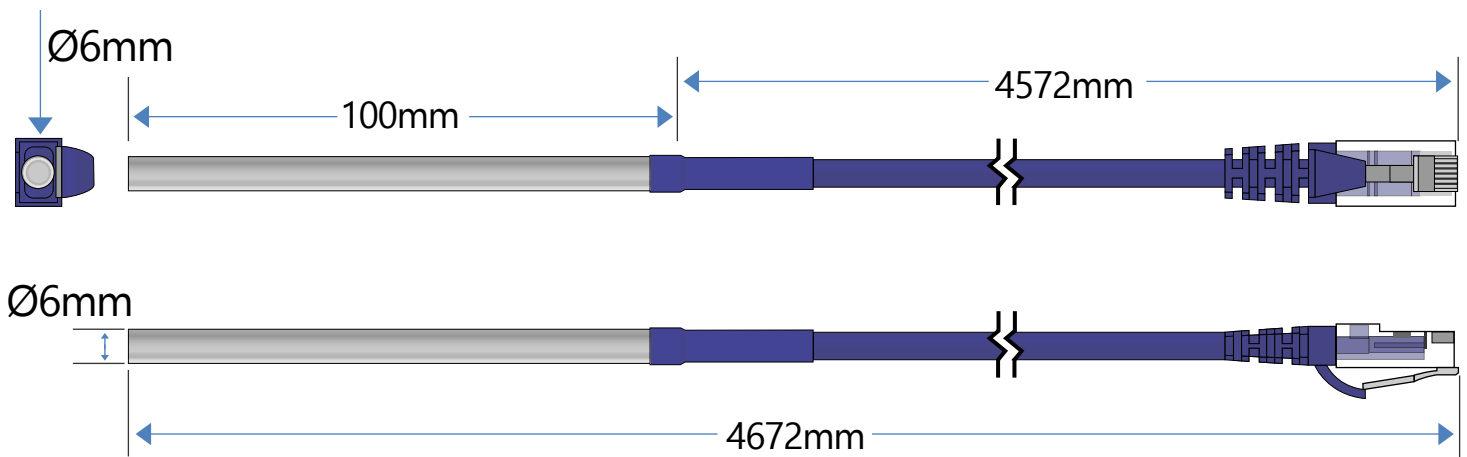

Ultra Cold Temperature Sensor (UCTX)



Suitable for temperatures as low as -200°C (-328°F). Ideal for monitoring vaccines and medical products based on mRNA technology that require ultra cold storage. The sensor uses a platinum probe that varies in resistance with temperature changes.

The sensor has good stability with immunity to electrical noise making it also suitable for use in industrial environments as well as medical applications.

Technical Specification

Temperature	
Measurement Range	-200°C to $+150^{\circ}\text{C}$ -328°F to $+302^{\circ}\text{F}$
Measurement Resolution	0.1 $^{\circ}\text{C}$ increments 0.2 $^{\circ}\text{F}$ increments
Measurement Accuracy	Typical : * $\pm 0.15^{\circ}\text{C}$ * $\pm 0.3^{\circ}\text{F}$
Interface	
Communications cable	RJ-45 jack to sensor using UTP CAT5e/6 cable
Power source	Powered by the sensorProbe+ family units. No additional power needed
Maximum Cable Length	Length The UCTS sensor can be extended from the RJ-45 Intelligent Sensor ports on the base units up to 60 feet, or 18 meters using standard CAT5/6 LAN cable
Dimension	75 x 55 x 27 mm
Components	Manufactured using highly integrated, low power surface mount technology to ensure long term reliability.
Operating Environment	Temperature : Min. -35°C – Max. 80°C Humidity: Min. 20% – Max. 80% (Non-Condensing)
Sensor count	1
Important Note	Compatible only with sensorProbe+ platform

UCTxx - Technical Drawing

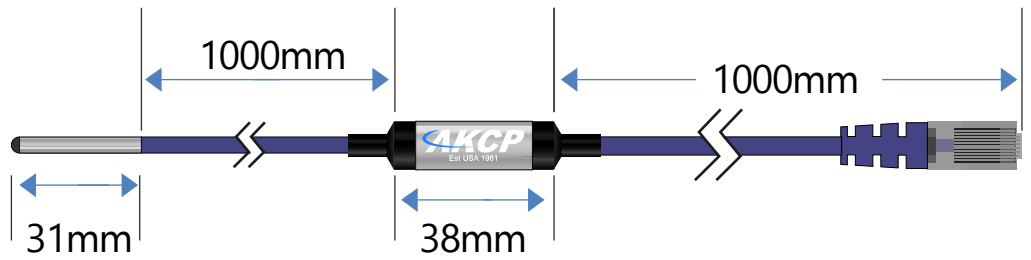
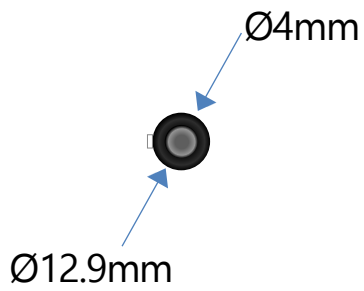

Dual Temp and Humidity Sensors (THS00 / THS01)

Accurate and responsive measurement of temperature and humidity. Available in fixed length or extendable version, the sensor is housed in a metal tube that is thermally conductive and perforated to still provide accurate readings.

THS00

The THS00 is supplied with a free 5ft cable, it can be extended using standard CAT5 up to 100 meters (330ft) from the AKCP base unit. The sensor can be mounted with screws, adhesive or with optional DIN rail clips



THS01

A short 1ft fixed cable with a dual temperature and humidity sensor on the end.



Dual Temp and Humidity Sensors (THSxx-NIST2 / NIST3)

If you're spending money for monitoring, wouldn't you want to know the sensors are calibrated?

2 NIST certified, calibrated temperature sensors are compared once a second for accuracy. (NIST2)

The NIST2 sensors feature a built in calibration check. Each unit has 2x NIST calibrated and certified temperature sensors. The primary sensor value is checked by the secondary sensor, and if we detect a range of greater than the stated accuracy we will alert that the sensor is out of calibration.

This makes these sensors ideal for situations where a high degree of accuracy is required and assurance of the calibration state

Calibration Check with Fail-over

3x NIST certified, calibrated temperature sensors are compared for accuracy, with a backup pair (NIST3).

The NIST3 sensors feature a built in calibration check. Each unit has three pairs of NIST calibrated and certified temperature sensors. The primary sensor value is checked by the secondary sensor, and if we detect a range of greater than the stated accuracy we will alert that the sensor is out of calibration. The sensor will then automatically fail-over to the second pair and continue monitoring with a seamless graph of data.

Suitable for situations where a high accuracy, calibrated sensors are needed, with backup for critical monitoring applications.

THS00 / THS01 / NIST2 / NIST3 - Technical Specifications

Temperature Measurement Range	-55°C to +75°C -67°F to +167°F
Measurement Resolution	sensorProbe+ series 0.1°C increments 0.2°F increments securityProbe series 0.5°C increments 0.9°F increments sensorProbe series 1°C increments 1°F increments
Measurement Accuracy	sensorProbe+ series and securityProbe series ±0.5°C accuracy from -10°C to +75°C ±0.9°F accuracy from +14°F to +167°F sensorProbe series ±1°C accuracy from -10°C to +75°C ±1°F accuracy from +14°F to +167°F
Humidity Measurement range	Humidity 0 to 100% Relative humidity
Resolution	1%RH increments, 0.01%RH sensor reading
Accuracy at	At 25°C Min : ±2%RH Max : ±5% RH
Interface Communications cable	RJ-45 jack to sensor using UTP CAT5e/6 cable
Power source	Powered by the base units. No additional power needed
Power Consumption	Typical 17.25mWatt, 1.45mA
Maximum Cable	THS00 - 330 feet (100 meters) with approved low capacitance shielded UTP cable THSxx - 100 feet (30 meters)
Sensor type	Semiconductor, microprocessor controlled
Dimensions	56 x 55 x 33.3 mm
Mounting	DIN rail mounting Screw mounting
Sensor count	2
Sensor count (NIST2/NIST4)	3
Important Note	The fixed one foot type or THS01 are not designed to be extended. If you need to extend these sensors then you need to use the THS00 (remote type). We also do not recommend you trying to connect any of our AKCP sensors including the temperature and dual temp humidity sensors though patch panels or using the RJ-45 couplers to extend them. Please see the temperature sensors product manual or FAQ in our knowledge base for more details regarding this.
Compatability	THSxx-NIST2 and THSxx-NIST3 compatible with sensorProbe+ series only

THS00 / THS01 / NIST2 / NIST3 - Technical Drawing

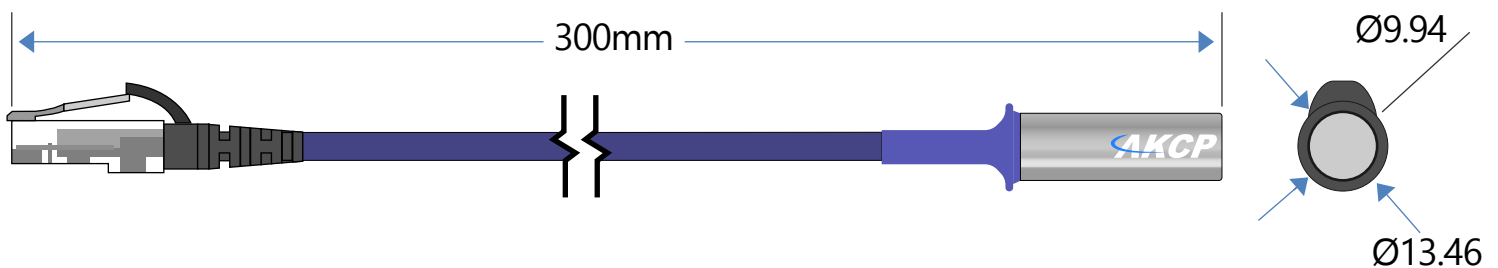
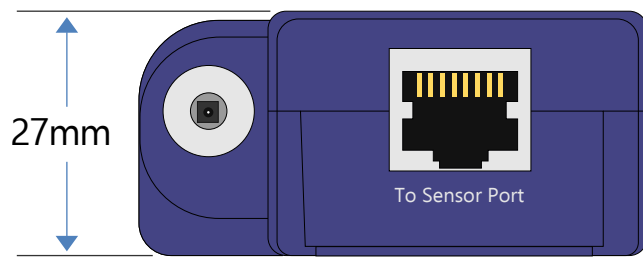
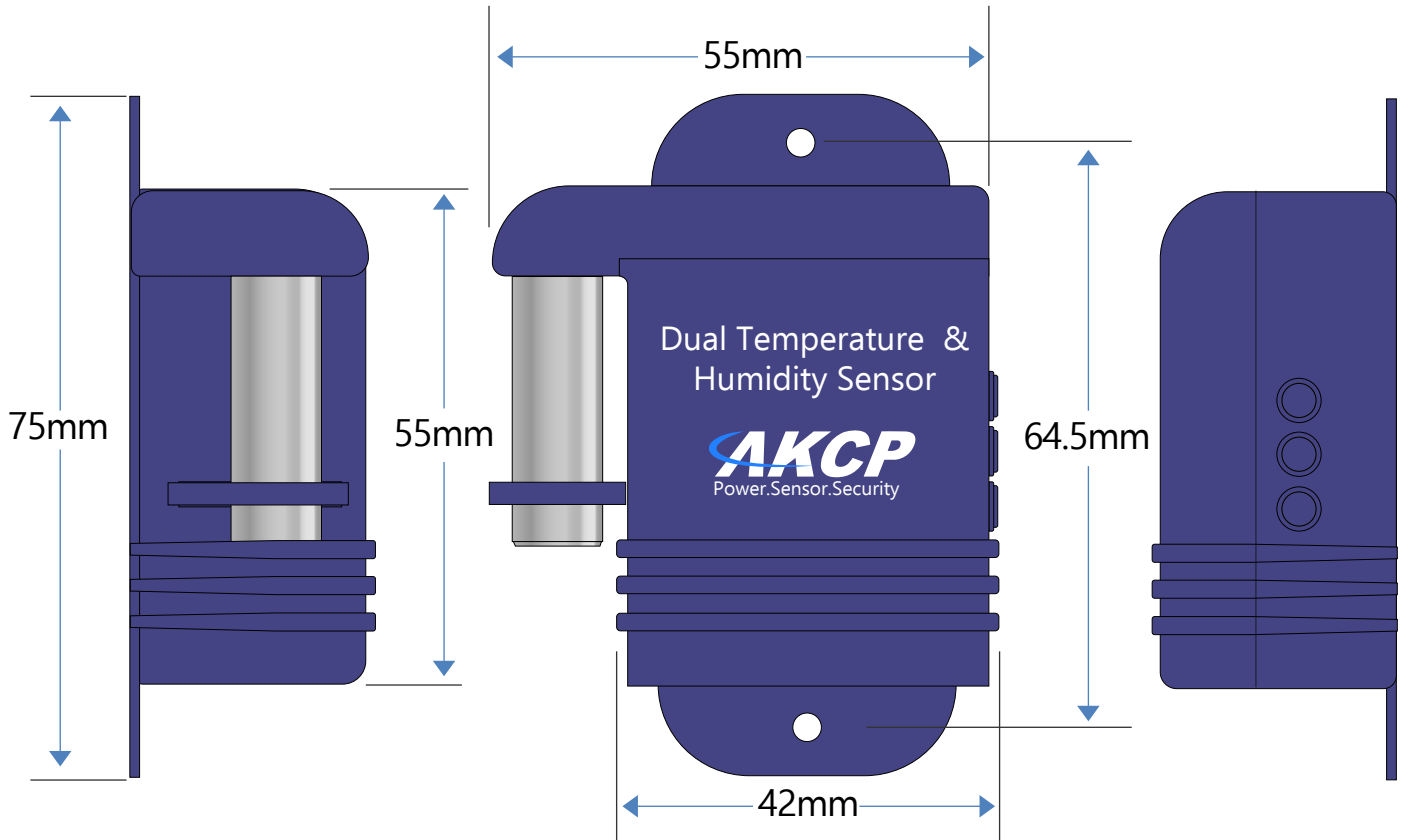

Spot Water Sensor (WSxx)



Water leaks can be a disaster, causing damage and potential large monetary losses. Protect your facility and infrastructure using spot water sensors. Placed at strategic positions under raised flooring in a data center, they can be used as an early warning indicator when water may pose a threat. The Spot Water Sensor uses technology developed by AKCP to detect the presence of even de-ionised water.

Technical Specifications

Measurement Range	Wet or Dry
Sensor Type	Open/Closed contact input switch
	Patent pending, microprocessor controlled, capacitance measurement technology
	Able to measure distilled water
Measurement Rate	Multiple readings every second
Indication	LED for Status
Operating Temperature	-20 °C~60 °C 4 °F~140 °F
Interface	
Communications Cable	RJ-45 jack to sensor using UTP Cat 5 wire
Communications Cable Max. length	The Spot Water Sensor can be extended from the RJ-45 Intelligent Sensor ports on the base units up to 500 feet, or 150 meters using standard CAT5/6 LAN cable
Power Source	Powered by the controller unit. No additional power needed
	Full autosense including disconnect alarm
Power Consumption	Typical 65 mWatt, 13mA
Dimensions	55(W) x 39(H) x 27(D) mm
Mounting	Screw mounting
Important Note	AKCP does not recommend the spotWater Sensor to be placed on a conductive surface. If this is required, add the Insulation Coating P/N : WSIC to each spotWater Sensor ordered
Sensor count	1

WSxx - Technical Drawing

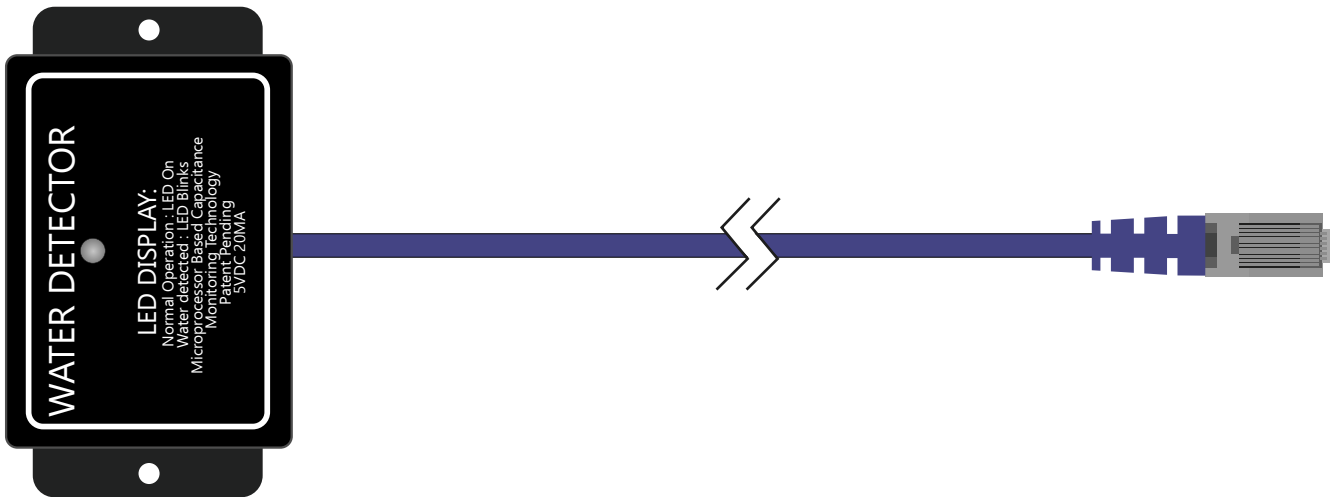
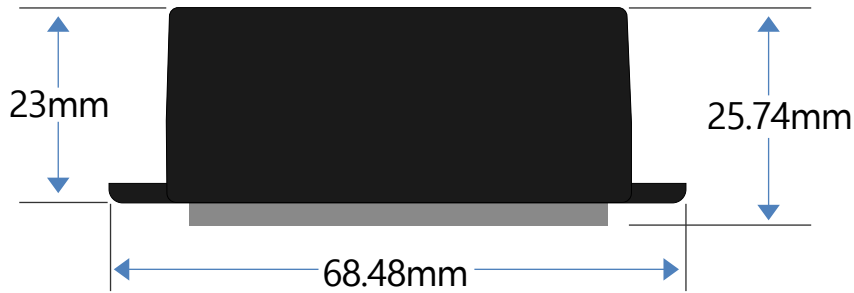
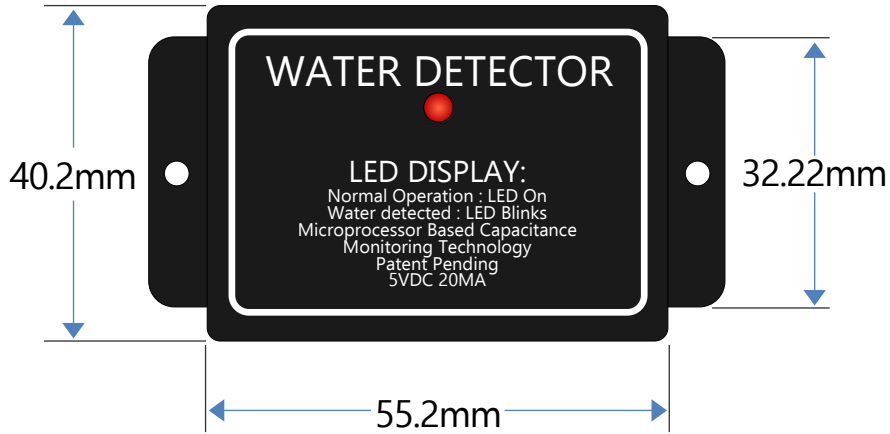

Rope Water Sensor (V2RWSCxx / RWSCxx / LWSCxx)



The rope water sensor comes in two parts, the orange non-sensing cable, and the yellow sensing cable. IP66 rated waterproof connectors join the two sections of rope together. Lay these rope water sensors out around the perimeter of your room, or underneath aisles in your data center to give early warning of potential water leaks and avoid costly damage.

RWSCxx / LWSCxx with additional female connector

Rope water sensors are available in three versions.

V2RWSCxx

This rope water sensor can not be extended, it has no additional female connector for connecting additional rope water sensing cable extensions.

RWSCxx

This rope water sensor can be extended. It has an additional female connector on the end to plugin an extension.

LWSCxx

Rope water sensor with locate capabilities. It can identify the number of feet / meters along the rope the first leak has been detected.



V2RWSCxx without additional female plug for extensions

V2 / RWSCxx - Technical Specifications

Measurement Range	Wet or Dry
Sensor Type	Open/Closed contact input switch
Measurement Rate	Multiple readings every second
	Able to detect the presence or non-presence of water
Indication	LED for Status
Operating Temperature	-20 °C~60 °C 4 °F~140 °F
Pull Force Limit	Not to exceed 50 lb
Bend Radius	2 in. (50 mm) minimum
Pressure	Loads greater than 20 lb (9 kg) per linear inch at 20°C (68°F) may immediately trigger an alarm
Interface	
Communications Cable	RJ-45 jack to sensor using UTP Cat 5 wire
Communications Cable Max. length	The Rope Water Sensor can be extended from the RJ-45 Intelligent Sensor ports on the base units up to 100 feet, or 30 meters using standard CAT5/6 LAN cable. Comes fully assembled including the Water sensing rope, the non-sensing cable that connects the rope to the sensing module and the main sensing module that connects via CAT5 LAN cable to the sensorProbe / securityProbe 5E. Sensing rope cable can be pre-ordered from a 10 feet minimum to any custom run length of up to 165 feet or 50 meters. Non-sensing cable comes in a standard 20 feet run length.
Power source	Powered by the controller unit. No additional power needed Full autosense including disconnect alarm
Power Consumption	Typical 125 mWatt, 25 mA
Dimension	56 x 55 x 33.3 mm
Mounting	DIN rail mounting Screw mounting
Important Note	AKCP does not recommend the ropeWater Sensor to be placed on a conductive surface. Or nearby power cables that can cause electro magnetic interference with the cable resulting in false alerts.
Sensor Count	1

LWSCxx- Technical Specifications

Measurement Range	Wet or Dry Closest location detection
Measurement Rate	Multiple readings every second
	Able to detect the presence of water at specific location
Indication	LED for Status
Operating Temperature	-20 °C~60 °C 4 °F~140 °F
Pull Force Limit	Not to exceed 50 lb
Bend Radius	2 in. (50 mm) minimum
Pressure	Loads greater than 20 lb (9 kg) per linear inch at 20°C (68°F) may immediately trigger an alarm
Interface	
Communications Cable	RJ-45 jack to sensor using UTP Cat 5 wire
Communications Cable Max. length	The Locate Rope Water Sensor can be extended from the RJ-45 Intelligent Sensor ports on the base units up to 200 feet, or 60 meters using standard CAT5/6 LAN cable. Comes fully assembled and includes the rope portion that is the water sensing cable, the nonsensing area cable (from the rope to the sensing module) and the main sensing module Sensing rope cable can be pre-ordered from a 10 feet minimum to any custom run length (in multiples of 10 feet) of up to 100 feet or 30 meters. Non-sensing cable comes in a standard 20 feet run length.
Power source	Powered by the controller unit. No additional power needed Full autosense including disconnect alarm
Power Consumption	Typical 125 mWatt, 25 mA
Dimension	56 x 55 x 33.3 mm
Mounting	DIN rail mounting Screw mounting
Important Note	AKCP does not recommend the ropeWater Sensor to be placed on a conductive surface. Or nearby power cables that can cause electro magnetic interference with the cable resulting in false alerts.
Sensor Count	1

V2RWSCxx - Technical Drawing

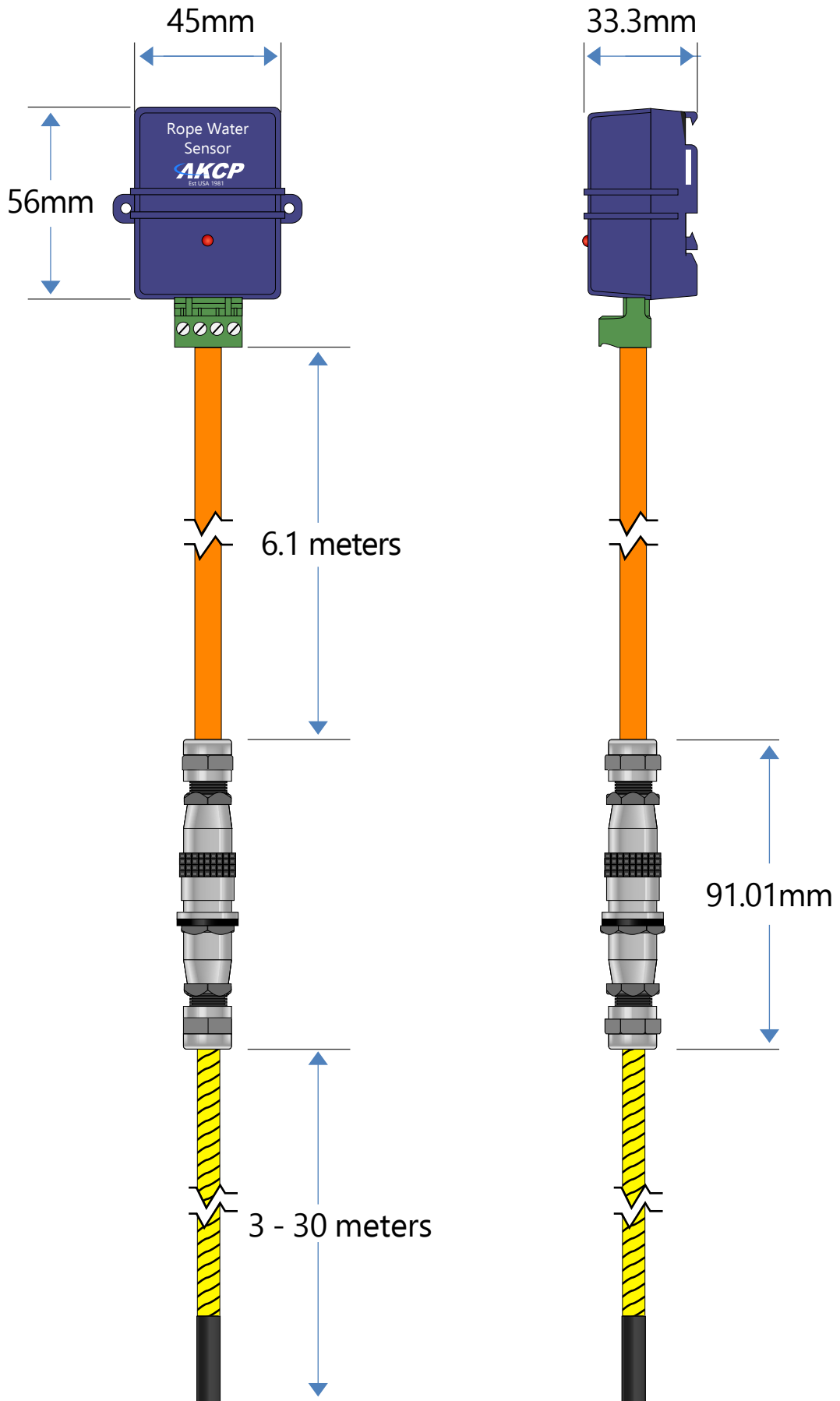

RWSCxx / LWSCxx - Technical Drawing

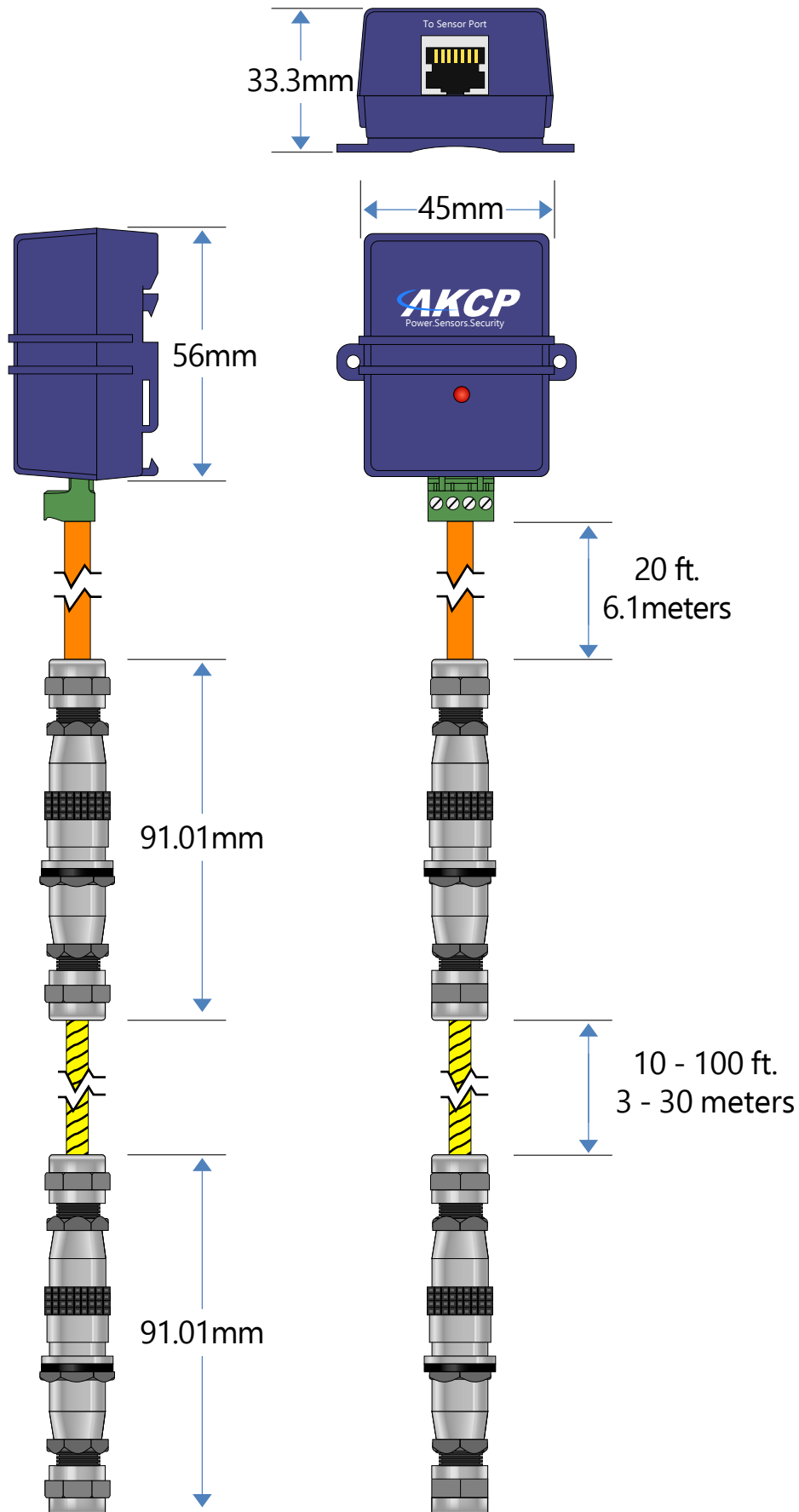

Airflow Sensor (AFS00)



The airflow sensor is a switch type on/off style sensor. It is not a precision air-flow measurement sensor, but rather an indicator of whether there is a presence or absence of airflow. A threshold can be set to determine the sensitivity of the sensor. Ideal for placing in-front of air intake or exhaust fans to indicate if the airflow is sufficient and as an early warning of failures in the cooling systems or fans.

Technical Specifications

Measurement Range	Normal or Critical
Sensor Type	Thermistor / On or Off
Measurement Rate	Multiple readings every second
Indication	LED for Status LED for connectivity
Operating Temperature	-20 °C~60 °C 4 °F~140 °F
Interface	
Communications Cable	RJ-45 jack to sensor using UTP Cat 5 wire
Communications Cable Max. length	The AirFlow Sensor can be extended from the RJ-45 Intelligent Sensor ports on the base units up to 60 feet, or 18 meters using standard CAT5/6 LAN cable
Power Source	Powered by the controller unit. No additional power needed Full autosense including disconnect alarm
Power Consumption	Typical 430 mWatt, 85mA
Dimensions	56 x 55 x 33.3 mm
Mounting	DIN rail mounting Screw mounting
Sensor count	1

AFS00 - Technical Drawing

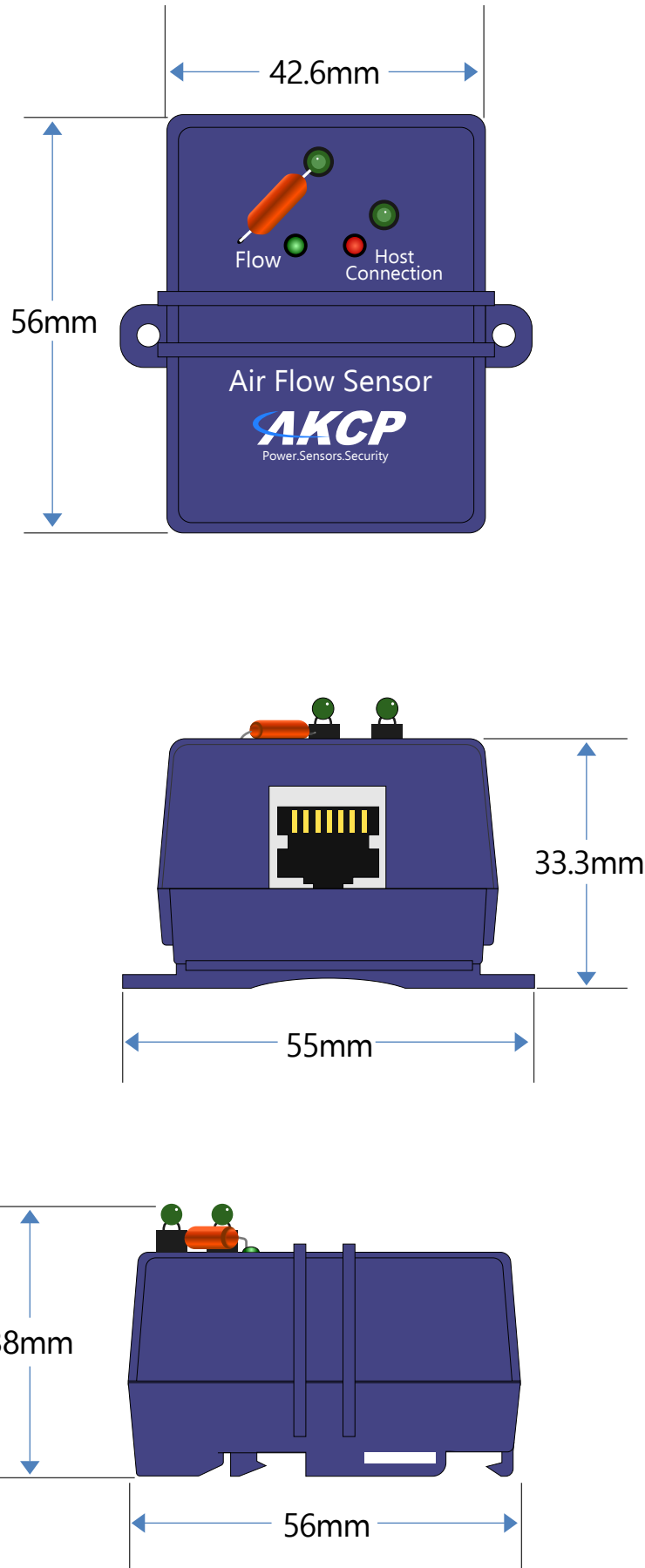

Thermocouple Sensors and Adapters (TCAK / TCAJ)



Thermocouples are used where you are exposing the sensor to extremes of temperature. Mostly used for industrial type applications, cryogenics and chemical industry. AKCP provides a complete thermocouple package as well as adapters for type K and J thermocouples if you have existing sensors that you wish to interface with our monitoring platform.



For customers who have an existing thermocouple of either a J or K type, we provide an adapter for interfacing this with our monitoring platform. This turns your thermocouple into a network enabled SNMP compliant thermocouple sensor that can be monitored remotely and send alerts via E-mail, SNMP and SMS when temperatures exceed your pre defined thresholds.

TCAK / TCAJ - Technical Specifications

Temperature	
Measurement Range	K Type : -200°C to +900°C -330°F to 1650°F J Type : -40°C to +750°C -40°F to 1382°F
Measurement Resolution	sensorProbe+ series 0.1°C increments 0.2°F increments securityProbe series 0.5°C increments 0.9°F increments
Measurement Accuracy	sensorProbe+ series and securityProbe series ±5°C ±9°F
Interface	
Communication Cable	RJ-45 jack to sensor using UTP CAT5e/6 cable Plugs directly into the AKCP J or K type thermocouple adapter
Power source	Powered by the base units. No additional power needed
Power Consumption	Typical 7.80 mWatt, 1.56 mA
Maximum Cable Length	Run length is 100 feet (30 meters) with approved low capacitance shielded cable or UTP
Dimension	0.61m x 4.5mm (sheath diameter)
Sensor count	1

J / K Type Thermocouple Adapter Only

Temperature	
Measurement Range	K Type : -200°C to +900°C -330°F to 1650°F J Type : -40°C to +750°C -40°F to 1382°F
Measurement Resolution	sensorProbe+ series 0.1°C increments 0.2°F increments securityProbe series 0.5°C increments 0.9°F increments
Measurement Accuracy	sensorProbe+ series and securityProbe series ±5°C ±9°F
Interface	
Communications cable	RJ-45 jack to sensor using UTP CAT5e/6 cable Plugs directly into the AKCP J or K type thermocouple adapter
Power source	Powered by the base units. No additional power needed
Power Consumption	Typical 7.80 mWatt, 1.56 mA
Maximum Cable Length	Run length is 100 feet (30 meters) with approved low capacitance shielded cable or UTP
Sensor Connector	Compatible with industry standard J/K type thermocouples
Dimensions	56 x 55 x 33.3 mm
Sensor count	1

TCAK / TCAJ - Technical Drawing

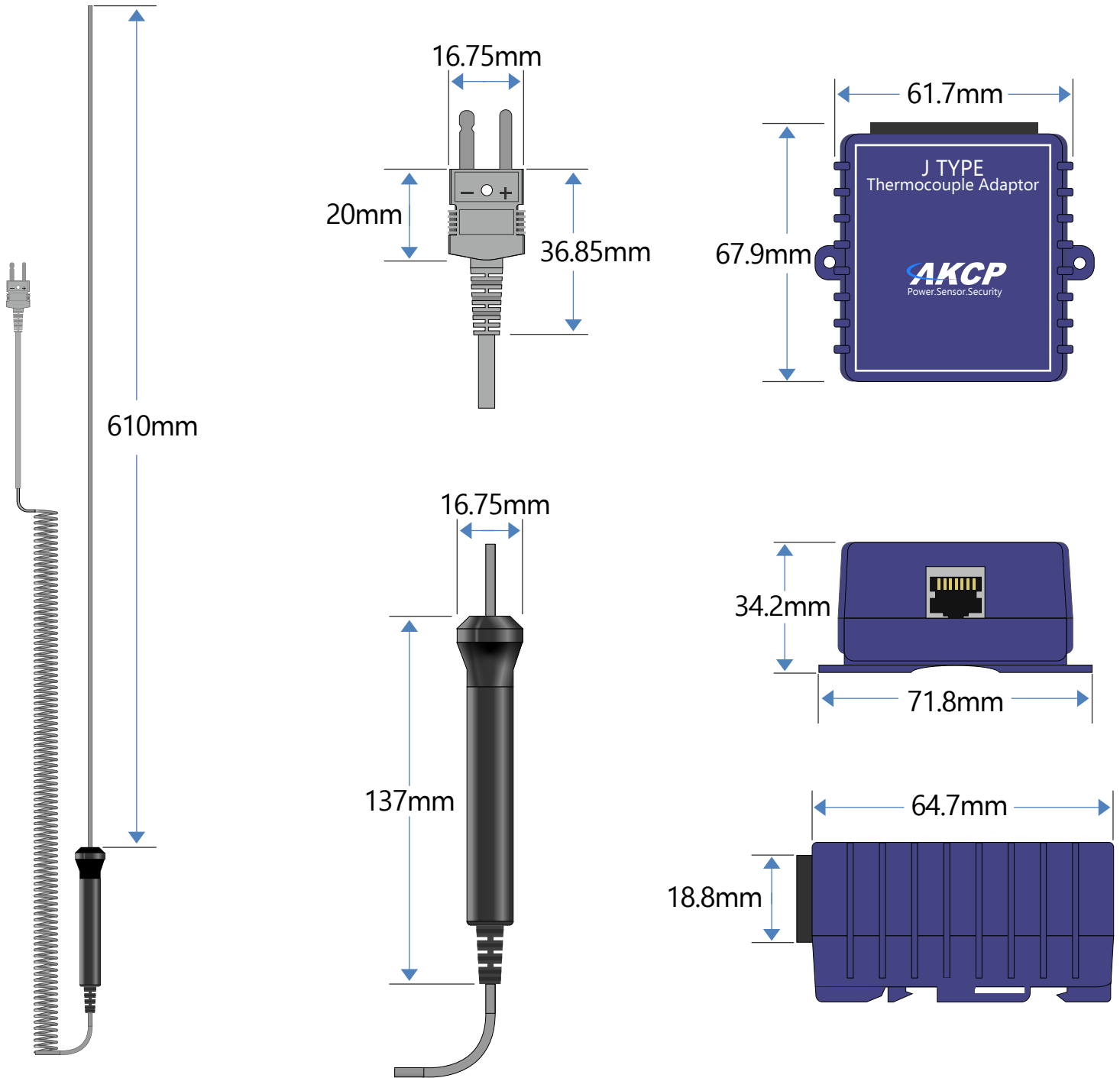

Security Sensors

AKCP provides a variety of sensors that can be used for security applications. Protect your facilities and assets from theft or fire damage, control access to cabinets and detect the status of doors and windows.



**RFID Swing
Handle Lock**



Siren & Strobe



Sensor Status Light



Vibration Center

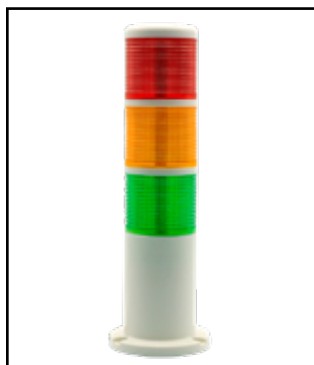

Sensor Status Light

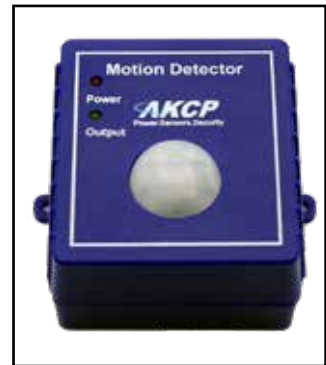

Motion Detection



Smoke Detector

Security Sensor (SSxx)

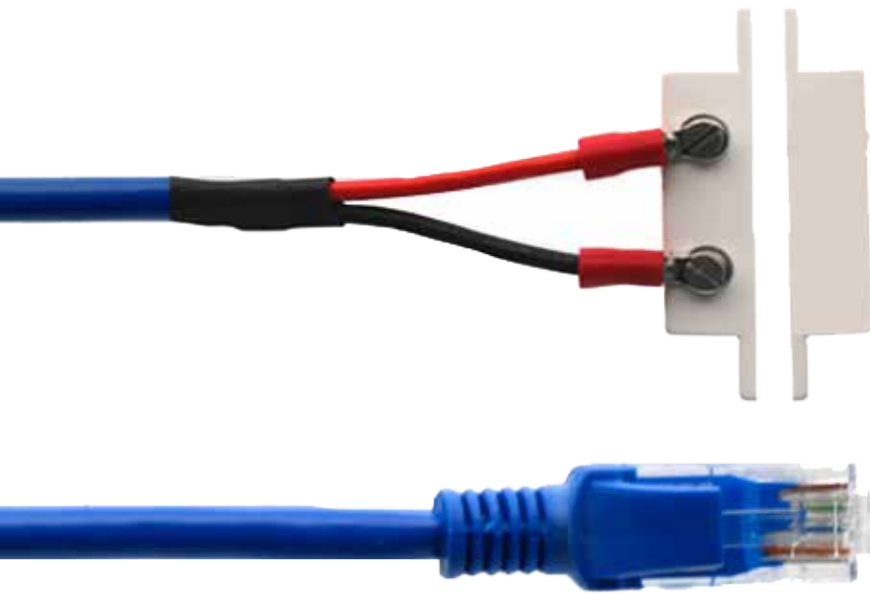

Security Sensors are simple magnetic contact switches that can be placed on any door, cabinet or window to sense the open or closed position. Ideal for using when you need to simply know if a door is open or closed without controlling access. Security Sensors can be daisy-chained together with several on a single sensor port, although in this configuration you will not know which sensor is critical just that one sensor in the string is in critical state.

Security Sensors are available in custom lengths, or choose from our standard lengths (SS15 comes with 15ft cable for example).

Technical Specifications

Measurement Range	Alarm or Normal
Sensor Type	Open / Closed magnetic switch
Input Measurement Rate	Multiple readings every second Normal input state is settable under software
Features	Unlimited number can be wired in series using one Port No reasonable limitation on distance from base unit
Interface	
Communications cable	RJ-45 jack to sensor using UTP Cat 5 wire
Communications Cable Max. length	1000Ft (305m) with approved low capacitance shielded cable or UTP
Power Source	Powered by the sensorProbe2 or sensorProbe2+. No additional power needed Full autosense including disconnect alarm
Power Consumption	Typical 8.95 mWatt, 1.79mA
Sensor count	1

SSxx - Technical Drawing

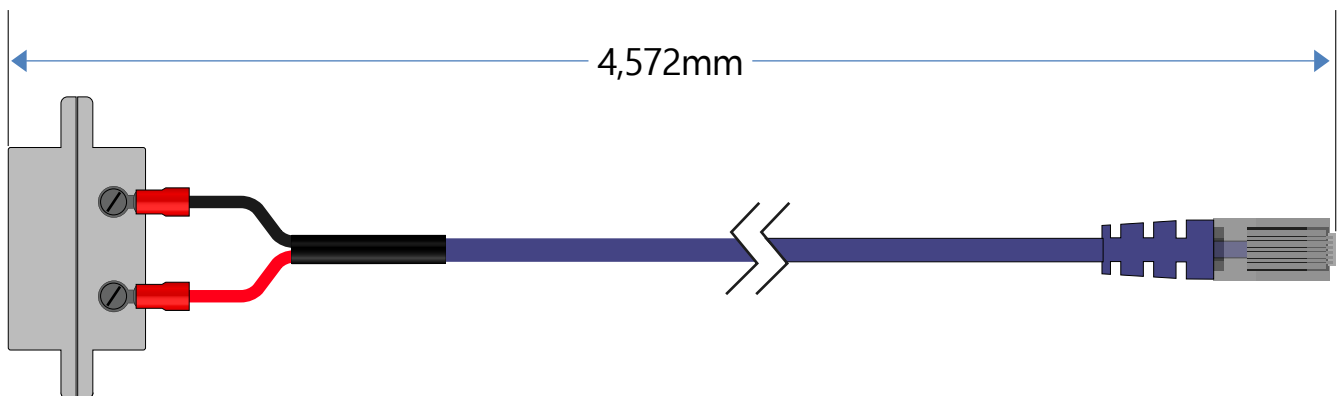
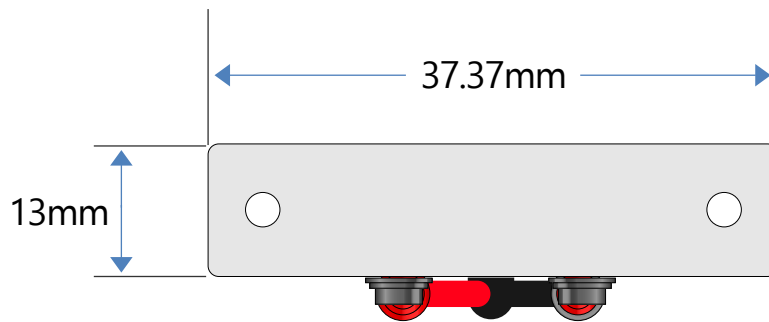
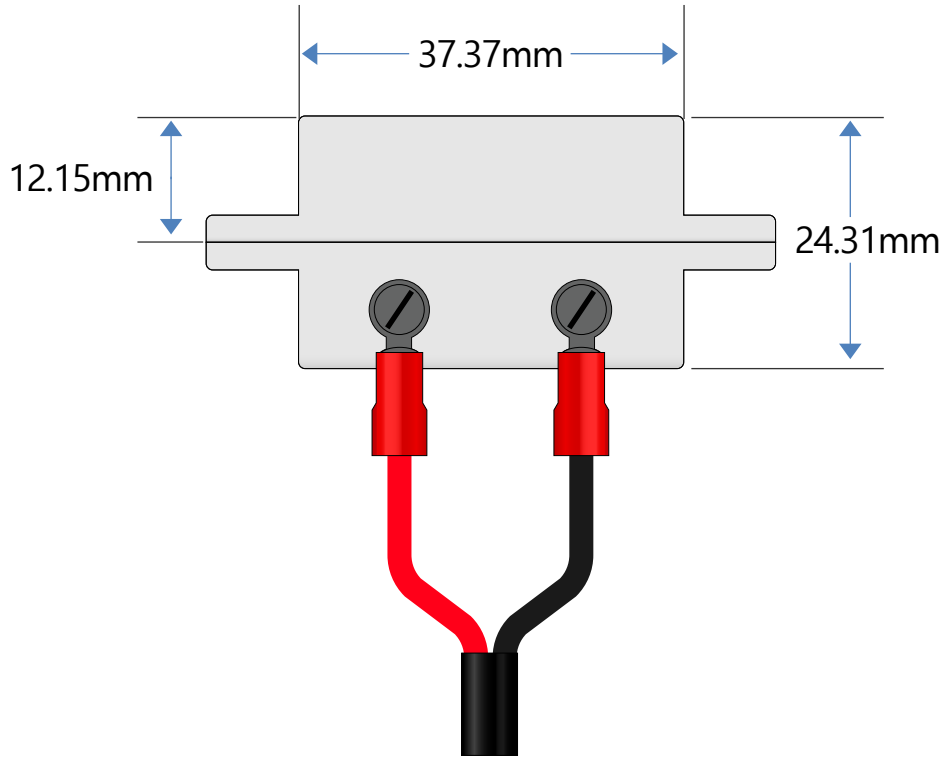

Vibration Sensor (VDS)



Install Vibration sensors on cabinets, safes, floors or walls and detect when vibration occurs. Use for being alerted if an object is moved, or if a cabinet is being forcibly opened.

Detect if walls are being broken with jackhammer, or forced entry with crowbar or saw. Alerts will be sent when an undesirable force is applied to the surface you are protecting.

The vibration sensor has a built in tamper switch which is independent of the main vibration sensor circuit to alert should the sensor be tampered with or disconnected.

Technical Specifications

Measurement Range	Alarm or Normal
Sensor Type	Normally Closed contact input switch
Contact Pressure	Adjustable from 1 to 50 grams but recommended setting between 5 and 25 grams only. Supplied with pressure of approximately 6 grams. Unlimited number can be wired in series using one Port
Contact Break Time	Approximately 45ms maximum (at 6-grams of pressure)
Rated	1A at 50VDC
Life	Over 100,000 contacts
Contacts	Pure silver
Case	ABS resin
Interface	
Communications Cable	RJ-45 jack to sensor using UTP Cat 5 wire
Communications Cable Max. length	1000Ft (305m) with approved low capacitance shielded cable or UTP
Power Source	Powered by the controller unit. No additional power needed Full autosense including disconnect alarm
Dimensions	15mm(H) x 21mm(W) x 60mm(L)
Weight	20 grams.
Sensor count	1

VDS - Technical drawing

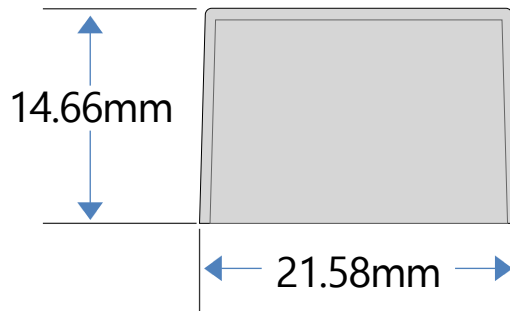
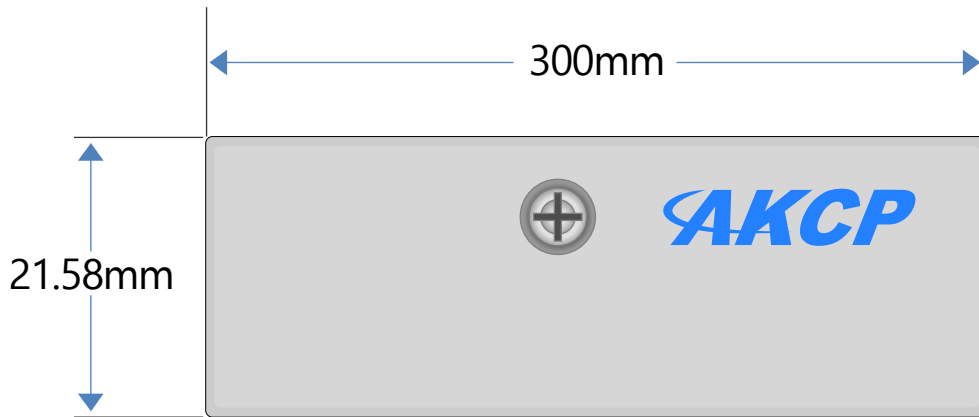

Motion Detector (MD00)



Infrared motion detection, is a hardware based motion detection technology that will detect movement up to 3 meters away. MD00 can be daisychained together with a maximum of 10 in a single string, meaning a single sensor port can support 10 motion sensors. When one motion sensor in the string is in critical state the whole string will show as critical.

Motion detectors can be used as a trigger of alarms and actions through the AKCP Base Unit. A siren and strobe light connected to the sensorProbe for example can be triggered based on the motion detectors status. Sensor controlled relays can be turned on, meaning that the motion detector can also be used to trigger any DC or AC powered device, whether it be an alarm or light.

Motion Detector (MD00) - Technical Specification

Measurement Range	Alarm or Normal
Sensor Type	Infrared sensor dual element High sensitivity
Detection angle	60°
	Maximum working distance is 3 m (9 Ft) High RFI immunity
Daisy Chainable	Up to 10 Motion Detector Sensors on a single port
	-20 °C~50 °C 4 °F~122 °F
Interface	
Operation Temperature	
Communications Cable	RJ-45 jack to sensor using UTP Cat 5 wire
Communications Cable Max. length	With approved low capacitance shielded cable or UTP Maximum cable length of single motion detector sensor is 300 m (100 Ft) Maximum total cable length of a string of 10 motion sensors is 46 m (150 Ft) Maximum length of cable between each motion sensor should less than 6 m (20 Ft)
Power Source	Powered by the controller unit. No additional power needed
	Full autosense including disconnect alarm
Power Consumption	Typical 50 mWatt, 10mA
Dimensions	65(W) x 62(H) x 15(D) mm
Weight	Wall/ceiling mounted design DIN rail mounting Screw mounting
Sensor count	1

MD00 - Technical Drawing

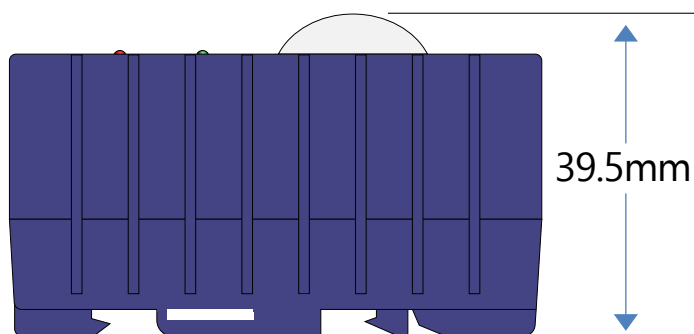
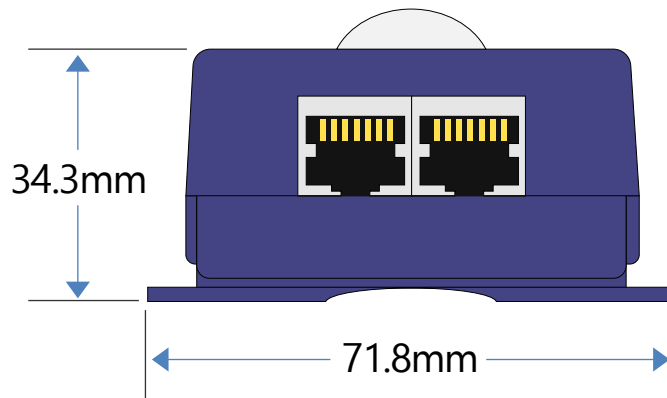
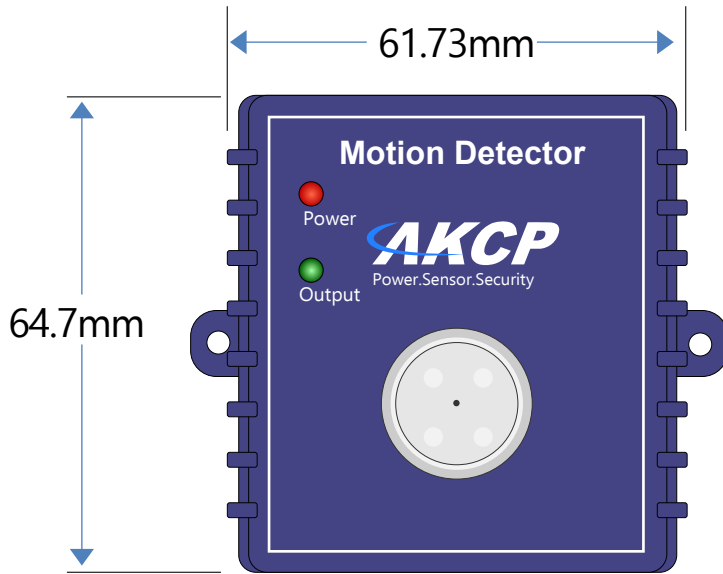

Siren and Strobe (STR00)



The Siren and Strobe light provides an audible and visual alarm when a sensor is in a critical state. Mount on the wall of a control room or security office and activate when a security breach occurs, for example.

Siren and Strobes can also be used as part of a systems and control system, to alarm when a machine is turning on or off, giving warning of danger to employees, as well as for security purposes.

In the data center, mount a Siren and Strobe on top of each cabinet, and alarm when a cabinet is in a critical state, alerting nearby technicians, and allowing them to easily locate the problematic cabinet by the flashing strobe light.

STR00 - Technical Specifications

Light Source	Super bright LEDs x8 400 flash Times/Minute
Sound	100dB ±3dB@100cm
Sensor Type	High / Low Output Switch
Control	ON or OFF
Optional	Manual Sound and Light variator
Operating Temperature	-40°C to 70°C
Storage Temperature	-40°C to 70°C
Interface	
Communications cable	RJ-45 jack to sensor using UTP CAT5e/6 cable
Power source	Powered by the controller unit. No additional power needed
Power Consumption	Typical 550 mWatt, 110mA
Maximum Cable Length	The Siren and Strobe Light can be extended from the RJ-45 Intelligent Sensor ports on the base units up to 100 feet, or 30 meters using standard CAT5/6 LAN cable
Dimensions	123 x 72 x 45 mm
Sensor count	1

STR00 - Technical Drawing

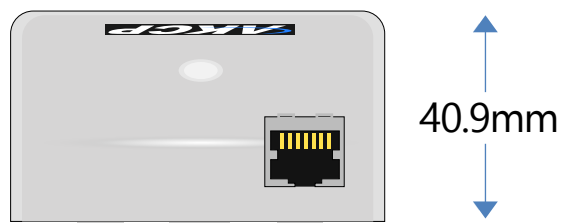
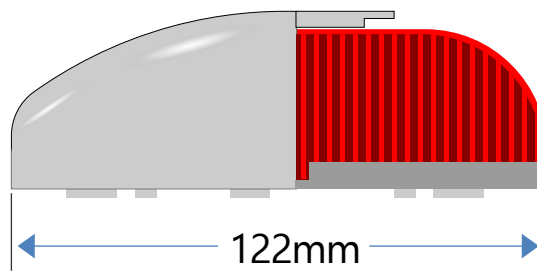

Smoke Detector (SK00)



Protect your facilities and infrastructure from fire with the AKCP Smoke Detector. Connect the sensor to any AKCP baseunit, either to an intelligent sensor port, or dry contact connection, and it forms a network based smoke detection and warning system. Monitor all your smoke detectors from a single user interface, with mapping features of AKCess Pro Server, you can see which alarm is critical at a glance.

Connect the sensor to both your fire alarm panel, and the AKCP base unit by using the dry contact connection for your alarm panel and the intelligent sensor port connection simultaneously.

SK00 - Technical Specifications

Measurement Range	Smoke or No Smoke
Sensor Type	Photoelectric Detector Type
	Suitable for installation to BS 5839 pt 6 Grade F
Output Type	Open/Closed contact switch
Features	Loud piercing 85db alarm at 3m
	Full function test button
	Alarm auto-reset
	Insect resistant chamber
	Low profile design for ceiling mounting for maximum smoke detection
	Conforms to UL 217 standard
Measurement Rate	Multiple readings every second
Indication	LED for Status Strobe Light when Smoke is detected
Operating Temperature	-20 °C~60 °C 4 °F~140 °F
Interface	
Communications Cable	RJ-45 jack to sensor using UTP Cat 5 wire
Communications Cable Max. length	The Spot Water Sensor can be extended from the RJ-45 Intelligent Sensor ports on the base units up to 500 feet, or 150 meters using standard CAT5/6 LAN cable
Power Source	Interface module powered by the base unit. Internal battery inside smoke detector. Full autosense including disconnect alarm
Power Consumption	Typical 290 mWatt, 58mA
Dimensions	Diameter 130mm, height 51mm
Mounting	Screw mounting
Sensor count	1

STR00 - Technical Drawing

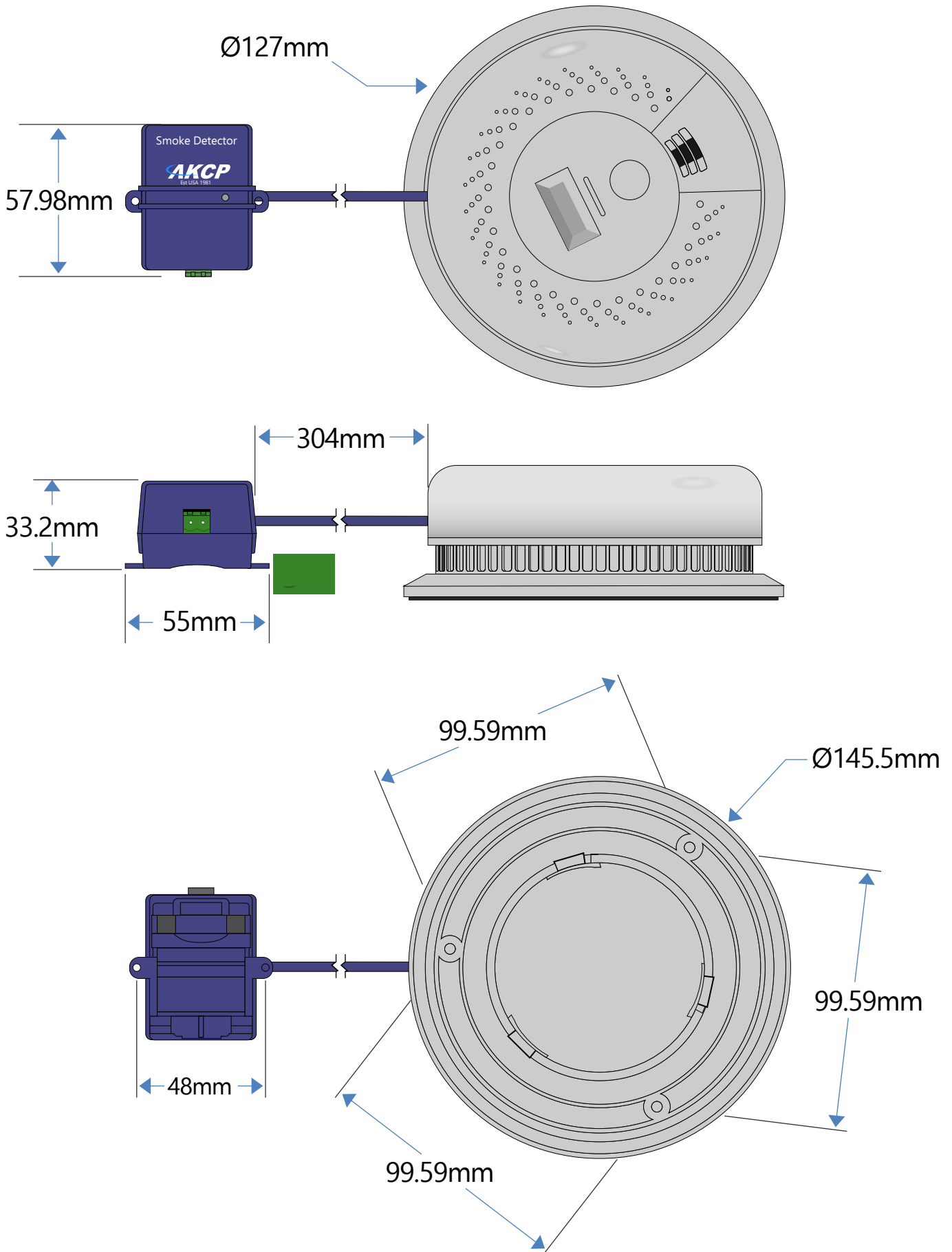

Sensor Status Light (SSL)



Connect the Sensor Status Light to any SPX+ or SP2+ sensor port. The light will change color based on a sensor status. Ideal for systems and control, factory automation and data center applications. Use as part of the Rack+ system to easily identify which cabinets in your data center are in a warning or critical state.

Every SSL comes with a buzzer for audible alarms. The buzzer can be turned on or off depending on your requirements. Three lights, Red, Amber and Green are programmed to illuminate or flash based on a sensor status input. Internal buzzer

SSL - Technical Specifications

Light Status	Green – Solid on, Very slow blink & Off Orange – Solid on, Slow blink & Off Red – Solid on, Fast blink & Off
Control	Notification control, Notification wizard connects light color to sensor input.
Alarm sound	Internal Buzzer for optional audible alert
Interface	
Communications cable	J-45 jack to sensor using UTP CAT5e/6 cable
Power source	Powered by the sensorProbe+ family units. No additional power needed
Power Consumption	Typical 200 mWatt, 40 mA
Maximum Cable Length	The SSL sensor can be extended from the RJ-45 Intelligent Sensor ports on the base units up to 100 feet, or 30 meters using standard CAT5/6 LAN cable
Dimension	75mm X 55mm X 27mm
Mounting	Desktop, Wallmount, Din rail, Magnetic
Components	Manufactured using highly integrated, low power surface mount technology to ensure long term reliability.
Operating Environment	Operating Environment Temperature : Min. -35° C – Max.80° C Humidity: Min. 20% – Max. 80% (Non-Condensing)
Important Note	Important Note - The Sensor Status Light sensor is only compatible with the sensorProbe+ platform units.
Sensor count	- When plugging the first time or after upgrading a sensorProbe+ unit, the sensor firmware might be upgraded by the unit and not be available right away. - On the sensorProbeX+, the sensor firmware can be upgraded only on the main module sensor ports
	Sensor count

SSL - Technical Drawing

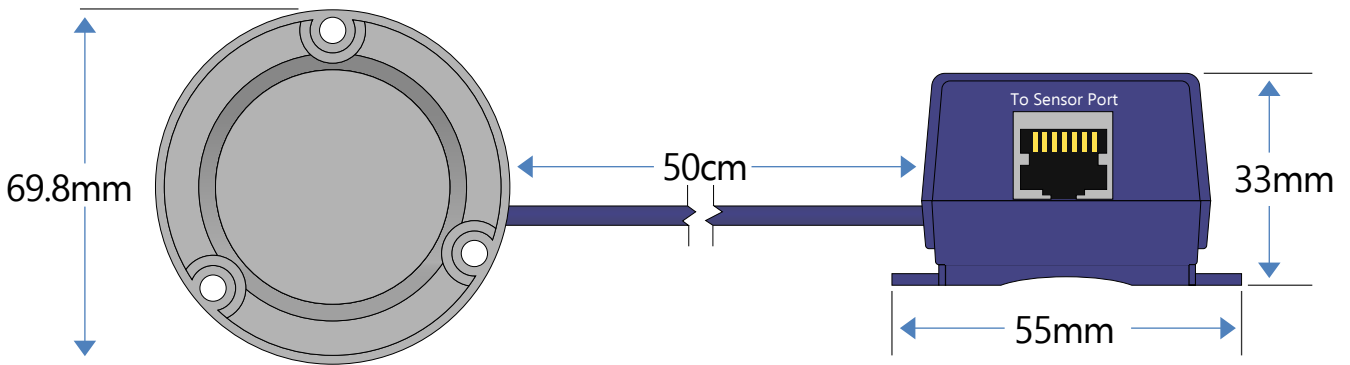
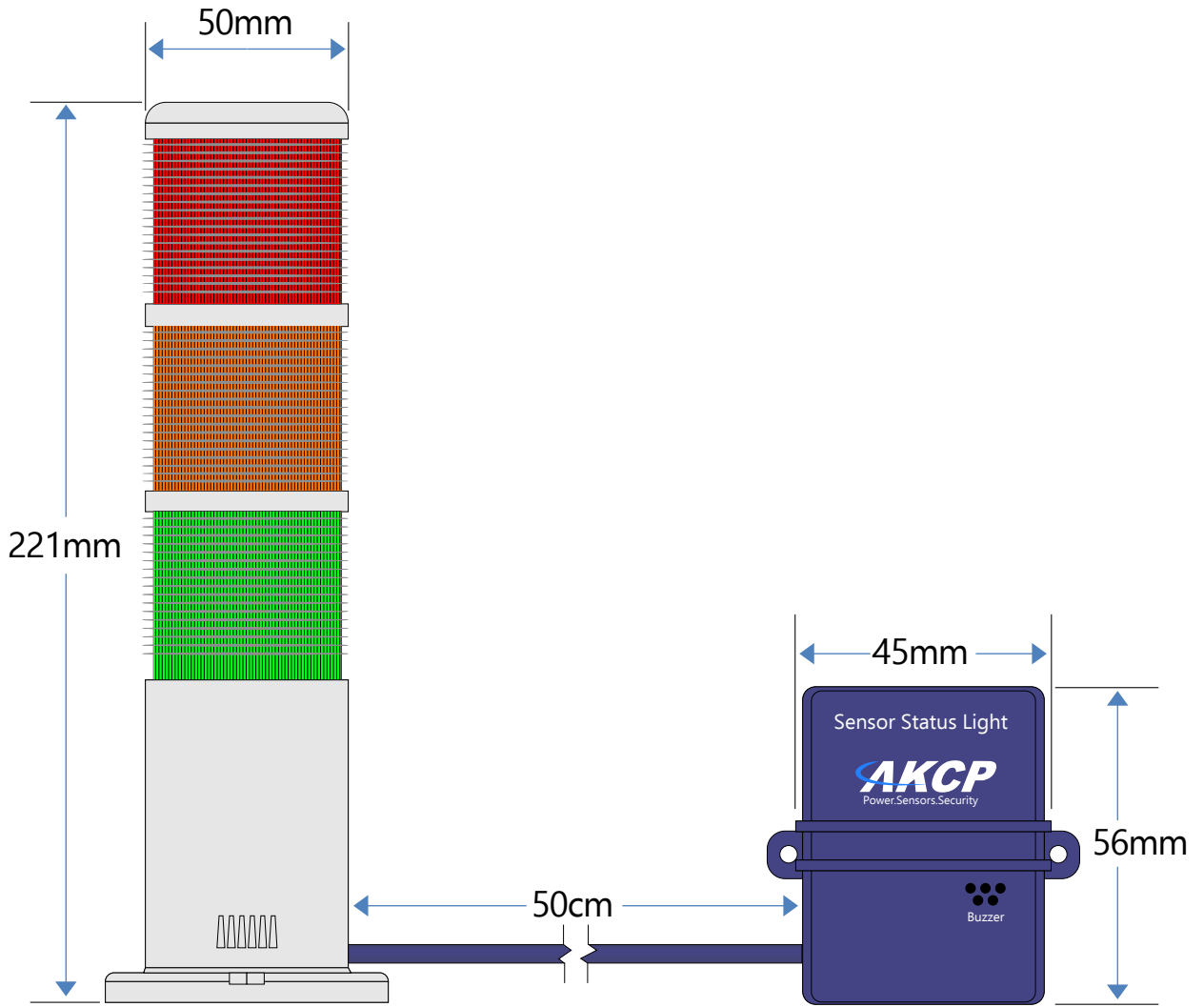

Power Sensors

Power sensors cover a variety of applications, no matter your power monitoring requirements AKCP has the right sensor for you.



4-20mAmp Sensor



Mini Sensor Controlled Relay



Isolated DC Voltage Meter



5 Dry Contact Inputs (SP2 and SP2+ only)



AC Sensor Controlled Relay



AC Current Transformers



8 x Digital I/O



Contactless Current Meter



DC Sensor Controlled Relay



Dry Contact Cable



Battery Monitoring



In-Line Power Meter



AC Voltage Sensor

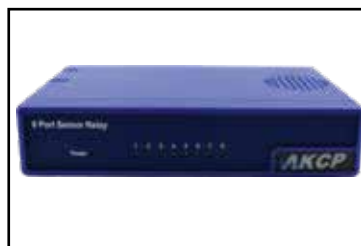

8 Port Sensor Controlled Relay



Power Monitoring Sensor

4-20mA Sensor (VC00)



Integrate Third Party Sensors

4-20mA sensor can be used to interface third party sensors with your AKCP base unit. There are many industrial and scientific sensors that output a 4-20mAmp signal. Programming of the sensor scale is done through the base units user interface. This makes it very easy to interface specialized sensors with AKCP devices, allowing you to take advantage of the alerts and monitoring they provide.

Typical third party sensors with 4-20mAmp output are:

- CO2 sensors
- PH meters
- Air Particle Sensors
- Precision Airflow Sensors

The sensor comes in an innovative box with a variety of mounting options built in such as DIN rail mounting, keyhole, screw, pipe clamp and cable ties.

VC00 - Technical Specification

Measuring Specifications	
Input	2 pin Phoenix connector : 4-20mA Iin(+) and Iin(-) for current loop
Output	Voltage Range +0.4 V to +2.0 V
Linearity	± 0.09 % Full Scale, Maximum
Accuracy	± 0.15% Full Scale (± 0.3% Full Scale, Maximum)
Status Indication	LED indication for current detection
	LED indication for power
Electrical	no galvanic isolation
Components	Manufactured using highly integrated, low power surface mount technology to ensure long term reliability.
Operating Environment	Temperature : Min. -35° C – Max.80° C Humidity: Min. 20% – Max. 80% (Non-Condensing)
Interface	
Communications cable	RJ-45 jack to sensor using UTP CAT5e/6 cable
Power source	Powered by the controller unit. No additional power needed
Power Consumption	Typical 120 mWatt, 24mA
Maximum Cable Length	The 4-20mA sensor Adaptor can be extended from the RJ-45 Intelligent Sensor ports on the base units up to 50 feet, or 15 meters using standard CAT5/6 LAN cable
Dimensions	65(W) x 62(H) x 15(D) mm
Mounting	DIN rail mounting Screw mounting
Sensor count	1

VC00 - Technical Drawing

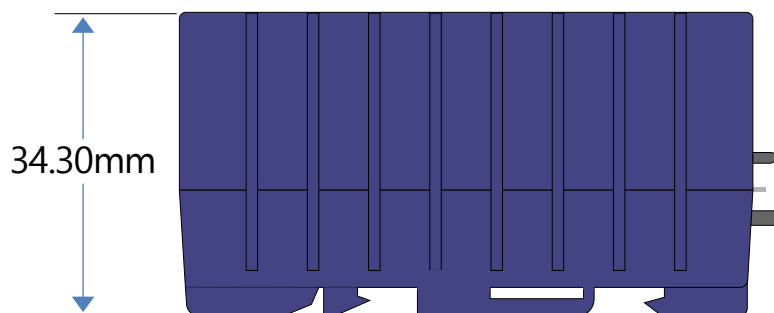
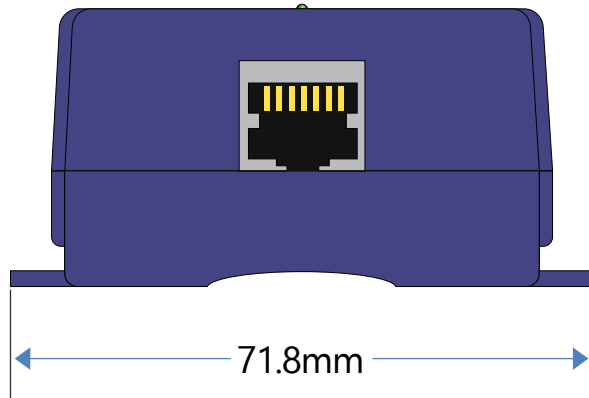
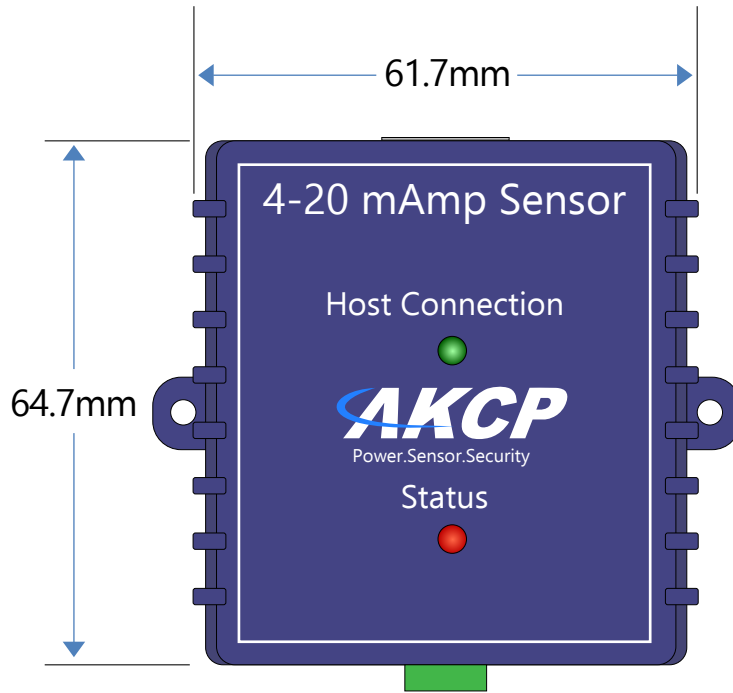

5 Dry Contact Inputs (5DCSxxx)



The single port RJ-45 Dry Contact Sensor with an ALARM/NORMAL indication in the software. Can have up to two on a SP2, four on an SP2+ eight on a SP8 and 600 Dry Contact Sensors on a securityProbe unit. Dry contact sensors are user definable and can be used to detect many different inputs such as UPS status, security systems, air conditioning status.

SNMP interface for alarm/normal status. SNMP traps can be sent when the sensor is in a critical state. SNMP polling is possible via SNMPget. Web browser interface is available. When an alarm condition is activated the description and location of the fault can be sent via an email or SNMP trap.

Technical Specifications

Measurement Range	Alarm or Normal
Sensor Type:	Open / Closed contact switch (input only)
Contact voltage range	5 volts pulled-up dry contacts*
Measurement Rate	Multiple readings every second
	Normal input state is settable under software
Interface	
Communications Cable	RJ-45 jack to sensor using UTP Cat 5 wire
Communications Cable Max. length	1000Ft (305m) with approved low capacitance shielded cable or UTP
Power Source	Powered by the controller unit. No additional power needed
Dimensions	56 x 55 x 33.3 mm
Mounting	DIN rail mounting Screw mounting
	Up to 5 dry contact inputs per RJ-45
	- making up to 10 Dry Contact Inputs in sensorProbe2
	- making up to 20 Dry Contact Inputs in sensorProbe2+
Important Note	Dry Contacts are not isolated, don't connect any voltage source
Sensor	5

5DCSxx - Technical Drawing

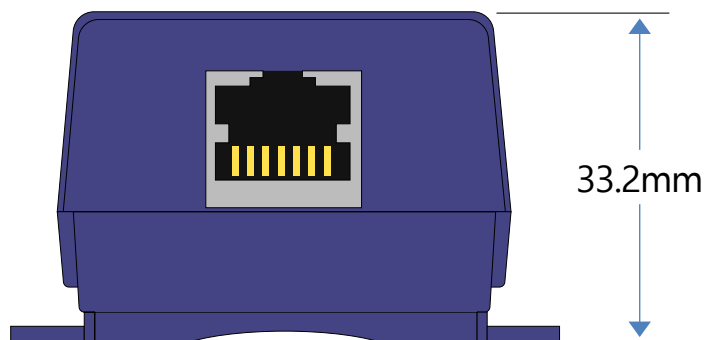
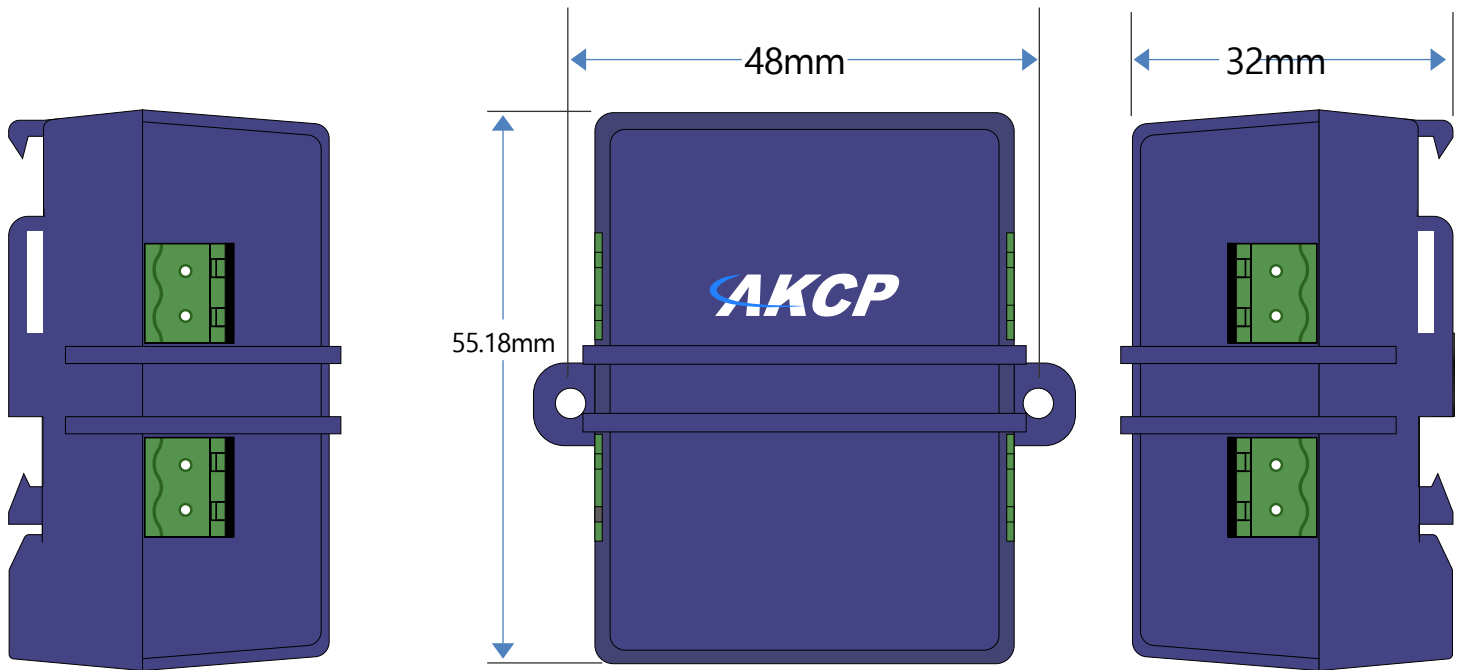
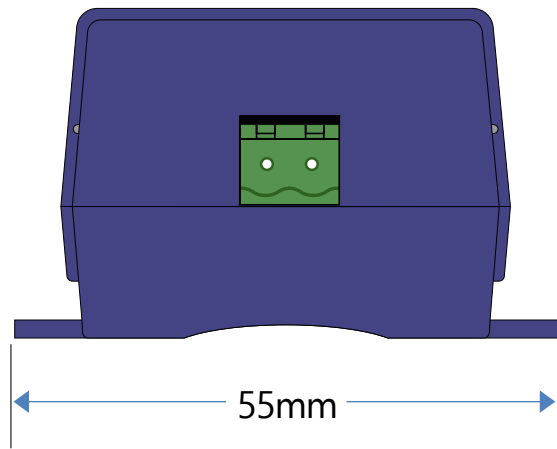

8 Port Sensor Controlled Relay (8PRB)



The 8 Port Sensor Relay is specially designed multi-port relay for advanced process control. The 8 Port Sensor Relay is easily controlled by any of AKCP's extensive selection of sensors. The relay can provide automatic responses to sensor status changes. Setting up the sensor controlled relay is easy with its built in autosense feature and user friendly web interface. When an alarm condition is activated the description and location of the fault can be sent via an email or SNMP trap.

Technical Specifications

Connector	Connector and Contacts rated up to maximum 5A @ 30 VDC, 5A @ 220 VAC 3 pin Phoenix Connectors : NO, NC, COM
Relay Ratings	Contact Material AgCdO Max. Operating Voltage 250 VAC Max. Operating Current 10 Amps Relay Contact Max. Switching Capacity + 16A@250VAC with Resistive Load, + 8A@250VAC with Inductive Load (P.F=0.4)
Status Indication	LEDs indicating the status of each Relay and Power Supply
Operating Temperature	-40°C to 70°C
Storage Temperature	-40°C to 70°C
Endurance	Max. Switching Rate: + 18,000ops./ min. (no load). + 1,800ops./ min. (rated load). Expected Mechanical Life: 20 million ops (no load). Expected Electrical Life: 100,000 ops (rated load).
Interface	
Communications cable :	RJ-45 jack to sensor using UTP CAT5e/6 cable
Power source :	7.5VDC 3A (optional, needed if there are more than 1 relay being used)
Power Consumption :	Typical 2475.00 mWatt, 495.00 mA
Maximum Cable Length :	The 8 Sensor Controlled Relay can be extended from the RJ-45 Intelligent Sensor ports on the base units up to 50 feet, or 15 meters using standard CAT5/6 LAN cable
Dimensions	10.83 x 5.43 x 1.80
Sensor count	8

5DCSxx - Technical Drawing

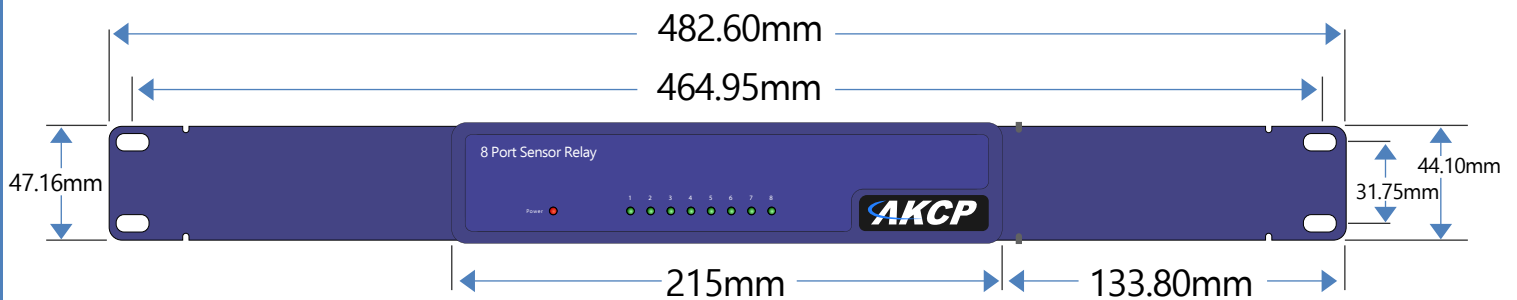
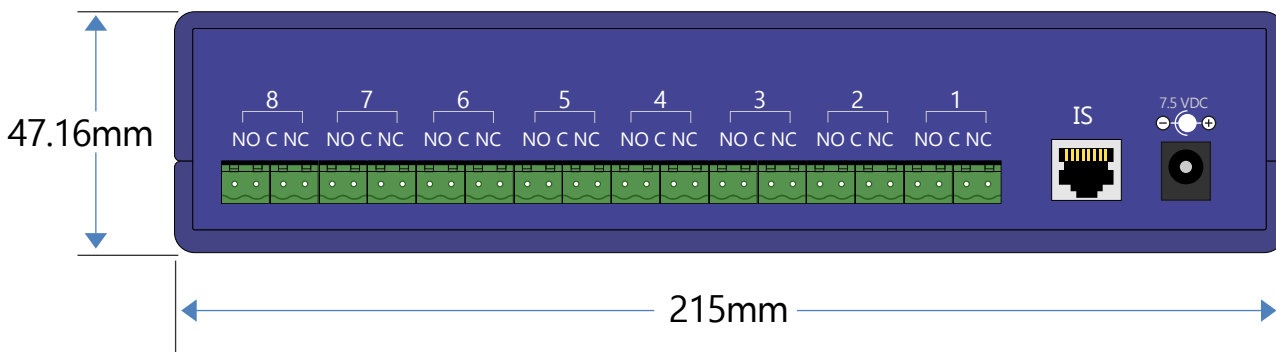
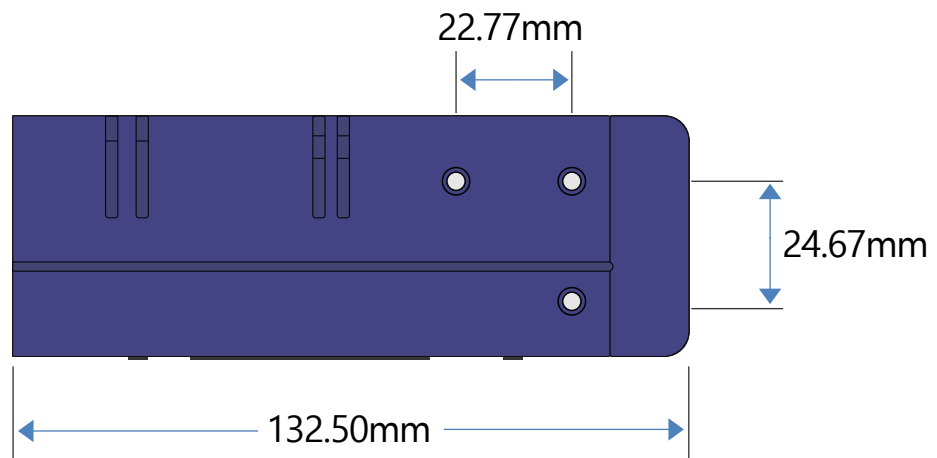
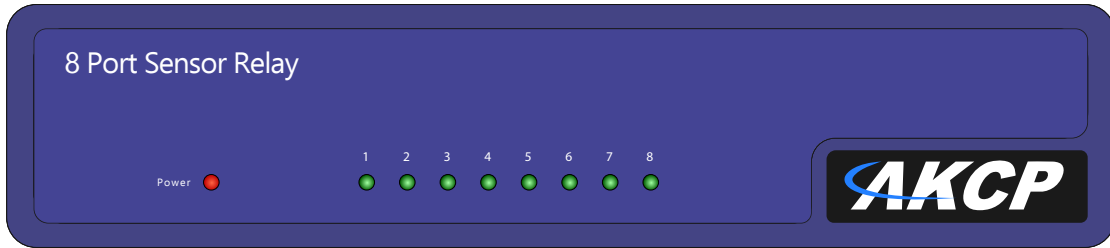

8 Port Sensor Controlled Relay

AC Sensor Controlled Relay (PRB00-ACO)



The AC-Sensor Controlled Relay controls the electrical power to devices over the Internet. Easy configuration & integration with sensorProbe product series, It defines a new era in energy management. The AC-Sensor Controlled Relay provides 1 high power SPST 5V relay. It includes Metal Oxide Varistors (MOVs) and Snubber circuits to protect the open contact of the relays from the high voltage spikes or noise transients.

PRB00-ACO - Technical Specification

Input Voltage	110-220VAC - IEC C14
Output Voltage	110-220VAC - IEC C13
Relay Ratings	IEC connector rating is 10 Amps for 220 VAC and 10 Amps for 110 VAC
	Contact Material AgCdO
	Carry Current 10 Amps
	Max. Operating Voltage 250 VAC
	Max. Operating Current 10 Amps
	Relay Contact Max. Switching Capacity
	+ 16A@250VAC with Resistive Load,
	+ 8A@250VAC with Inductive Load (P.F=0.4)
	10 Amps Fuse 380 VAC, 125 VDC
Status Indication	LED indication for input voltage
	LED indication for output voltage
	LED indication for sensor power
	LED indication for Relay state
Operating Temperature	40°C to 70°C
Storage Temperature	-40°C to 70°C
Endurance	Max. Switching Rate:
	+ 18,000ops./ min. (no load).
	+ 1,800ops./ min. (rated load).
	Expected Mechanical Life: 20 million ops (no load).
	Expected Electrical Life: 100,000 ops (rated load).
Interface	
Communications cable	RJ-45 jack to sensor using UTP CAT5e/6 cable
Power source	Powered by the controller unit. No additional power needed
Power Consumption	Typical 471.00 mWatt, 94.20 mA
Maximum Cable Length	The Sensor Controlled Relay can be extended from the RJ-45 Intelligent Sensor ports on the base units up to 100 feet, or 30 meters using standard CAT5/6 LAN cable
Dimensions	115 x 80 x 40 mm
Sensor count	1

PRB00-ACO - Technical Drawing

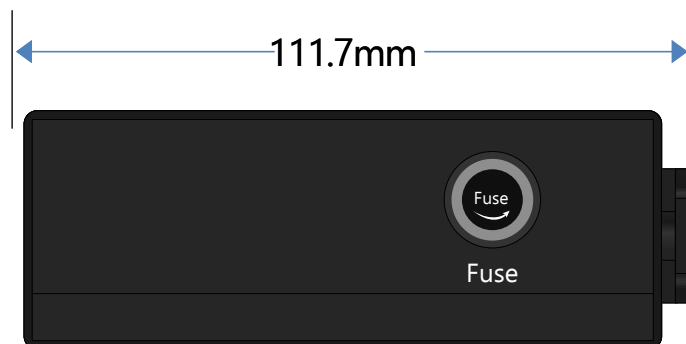
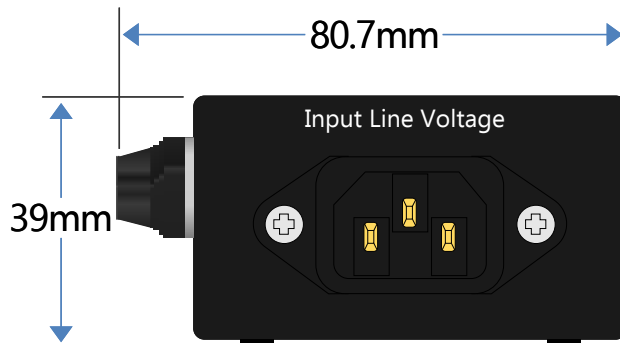
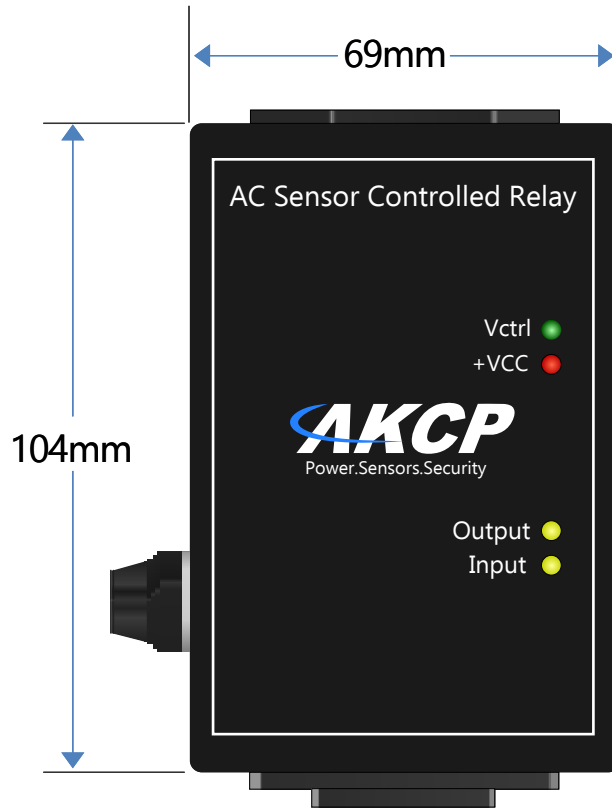

AC Voltage Sensor (ACV00)



AKCP Voltage sensor is specially designed for monitoring AC voltage presence or absence of line voltage up to 250V. It comes with an ALARM / NORMAL indication in the device firmware. Easy installation with no electrician required, it simply plugs into any AC power source and will monitor if AC Voltage is present.

Technical Specifications

Measurement Type	Normal or Alarm
Sensor Type	Open/Closed contact input switch
Voltage Range	50~250 VAC
Measurement Rate	Multiple readings every second
Indication	LED for Voltage presence
Operating Temperature	-20 °C~60 °C 4 °F~140 °F
Interface	
Communications Cable	RJ-45 jack to sensor using UTP Cat 5 wire
Communications Cable Max. length	The AC Voltage Sensor can be extended from the RJ-45 Intelligent Sensor ports on the base units up to 1000 feet, or 300 meters using standard CAT5/6 LAN cable
Power Source	Powered by the controller unit. No additional power needed
	Full autosense including disconnect alarm
Power Consumption	Typical 11 mWatt, 2.20mA
Dimensions	115 x 80 x 40 mm
Sensor count	1

ACV00 - Technical Drawing

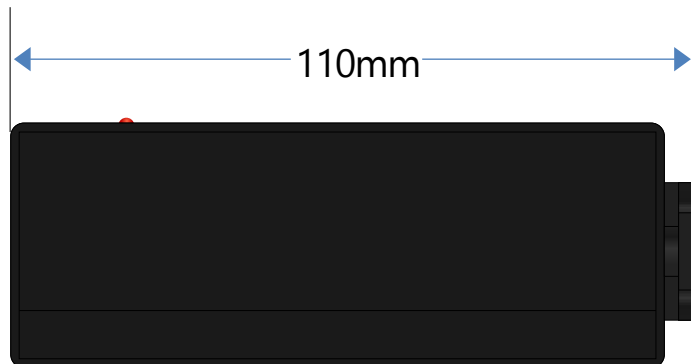
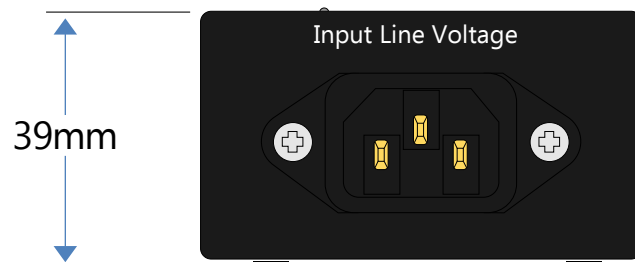
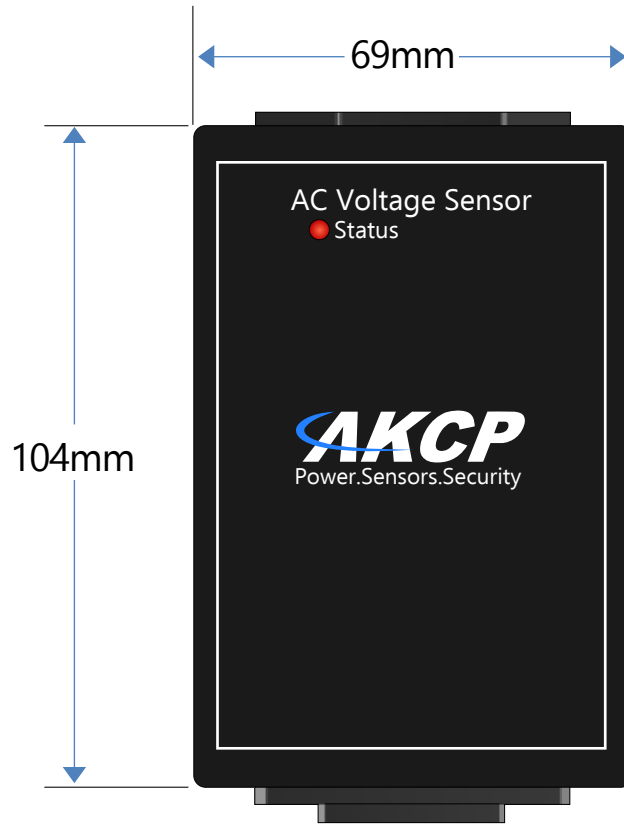

IO-Digital8 Sensor (IODC8)A



The IO-digital8 sensor adds 8 dry contacts to the securityProbe or expansion module base unit. With 8 ALARM/NORMAL indication in the securityProbe 5E web interface it provides instant notification for changes of status. The sensor can be mounted on a wall by your alarm panel, or using our DIN rail clips can be DIN rail mounted. A standard CAT5 cable connects the IO-digital8 sensor to the intelligent sensor port.

Technical Specifications

Measurement Range	Input: Alarm or Normal Output: Set or Reset
Sensor Type	Input : Open / Closed contact switch Output : High (5V) / Low (GND)
Contact voltage range	5 volts pulled-up dry contacts*
Input Measurement Rate	Multiple readings every second Normal input state is settable under software on each of the 8 dry contacts
Electrical Output	Normally open, normally closed is settable under software on each of the 8 dry contacts Can sink up to 20mA** on each of the 8 dry contacts (when set to Low)
Interface	
Communications Cable	RJ45 jack to sensor using UTP Cat 5 wire
Communications Cable Max. length	RJ45 jack to sensor using UTP Cat 5 wire, Maximum extension cable length 305m (1000 ft.) with approved low capacitance shielded cable or UTP
Power Source	Powered by the sensorProbe+ or securityProbe+. No additional power needed
	Full autosense including disconnect alarm
Important Note	*Dry Contacts are not isolated, don't connect any voltage source ** Dry contact output is not suitable for directly driving a relay
Sensor count	8

IODC8 - Technical Drawing

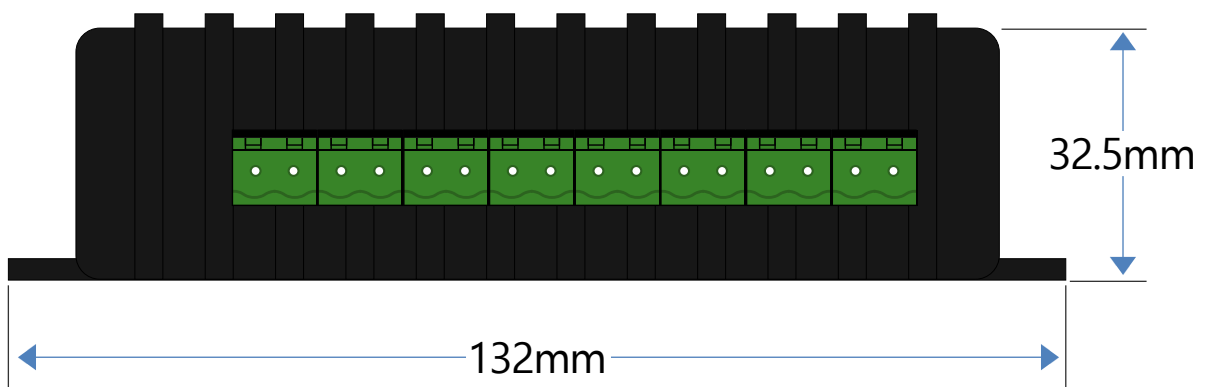
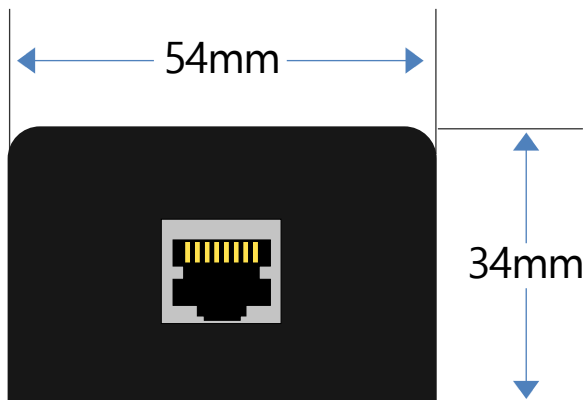
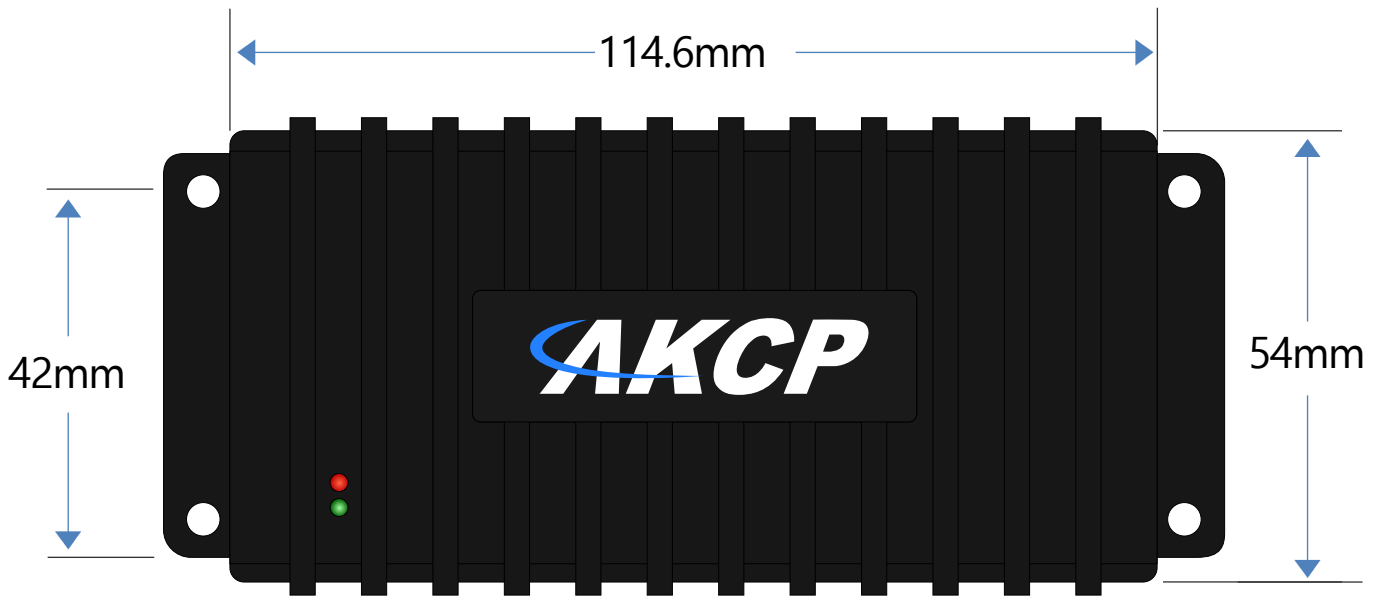

DC Sensor Controlled Relay (PRB00-DCO)



Control the power to devices managed over the Internet. With easy configuration and integration with AKCP base units.

The Sensor Controlled Relay is easily controlled by any of AKCess Pro's extensive selection of sensors. The relay can provide automatic responses to sensor alerts. This is useful, for example, to switch on the fan when the room temperature rises beyond the threshold level or to turn on a light when the motion detector is triggered. Setting up the Sensor Controlled Relay is easy with its built in autosense feature and user friendly web. When an alarm condition is activated the description and location of the fault can be sent via an email or SNMP trap.

PRB00-DCO - Technical Specification

Input Voltage	up to 125 VDC
Output Voltage	up to 125 VDC
Relay Ratings	Contact Rating – Contact Rated Load is 10 Amps at 30 VDC
	Contact Material AgCdO Carry Current 10 Amps Max. Operating Voltage 125 VDC Max. Operating Current 10 Amps Relay Contact Max. Switching Capacity + 480W with Resistive Load, + 350W with Inductive Load (L/R = 7 ms) 10 Amps Fuse 125 VDC
Status Indication	LED indication for input voltage LED indication for output voltage LED indication for sensor power LED indication for Relay state
Operating Temperature -40°C to 70°C	-40°C to 70°C
	40°C to 70°C
	Max. Switching Rate: + 18,000ops./ min. (no load). + 1,800ops./ min. (rated load). Expected Mechanical Life: 20 million ops (no load). Expected Electrical Life: 100,000 ops (rated load).
Interface	
Communications cable	RJ-45 jack to sensor using UTP CAT5e/6 cable
Power source	Powered by the controller unit. No additional power needed
Power Consumption	Typical 471.00 mWatt, 94.20 mA
Maximum Cable Length	The Sensor Controlled Relay can be extended from the RJ-45 Intelligent Sensor ports on the base units up to 100 feet, or 30 meters using standard CAT5/6 LAN cable
Dimensions	115 x 80 x 40 mm
Sensor count	1

PRB00-DCO - Technical Drawing

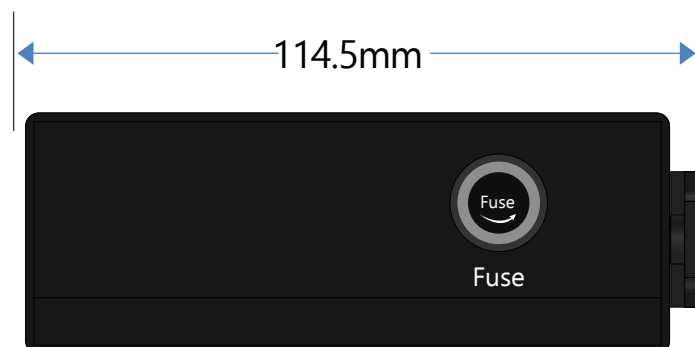
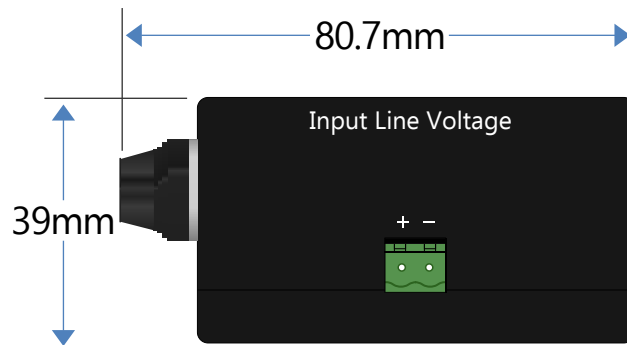
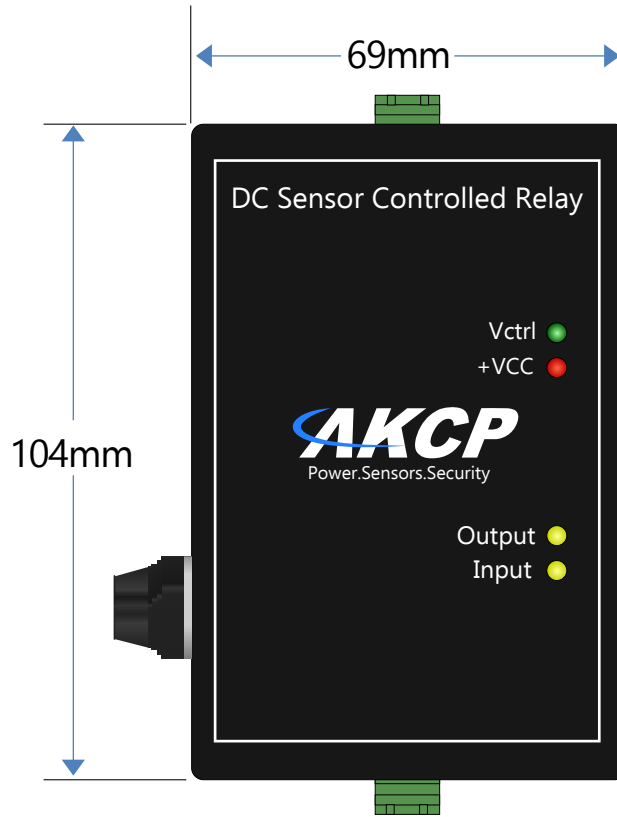

Mini Sensor Controlled Relay (MSCR)



Mini Relay Controlled by Sensor Status

Drive larger relays with a low current output from the sensorProbeX+

- If you have an equipment with a relay that you would like to switch based on a sensor input,
- this adapter will output 200mA - 5V DC based
- on a sensors status. Use this smaller relay as
- to drive the larger relay on your appliance.

MSCR - Technical Specification

Configuration	2 position switch configurations - 1. 5V and GND contacts (0.2A) - 2. Free contacts
Output	3 pin terminal Block - NO, NC, COM - 5V, GND, COM
Free Contact Voltage	24 VDC, Maximum 30 VDC 120 VAC
Relay Ratings	Contact Rating – + Contact Rated Load is 1Amp at 24 VDC + Contact Rated Load is 1Amp at 120 VAC Max. Operating Voltage 30 VDC, 120 VAC Max. Operating Current 1 Amp Max. Switched Power: 24W / 120VA.
Status Indication	LED indication for Relay active state
Operating Temperature	-40°C to 80°C
Storage Temperature	-40°C to 80°C
Endurance	Max. Switching Rate: + 300ops./ min. (no load). + 30ops./ min. (rated load). Expected Mechanical Life: 5 million ops (no load). Expected Electrical Life: 100,000 ops (rated load). Minimum Load: 1mA @ 1VDC.
Interface	
Communications cable	RJ-45 jack to sensor using UTP CAT5e/6 cable
Power source	Powered by the controller unit. No additional power needed
Power Consumption	Power Consumption Typical 150 mWatt, 30 mA
Maximum Cable Length	The Sensor Controlled Relay can be extended from the RJ-45 Intelligent Sensor ports on the base units up to 100 feet, or 30 meters using standard CAT5/6 LAN cable
Dimensions	56 x 55 x 33.3 mm
Mounting	DIN rail mounting Screw mounting
Sensor count	1

MSCR - Technical Drawing

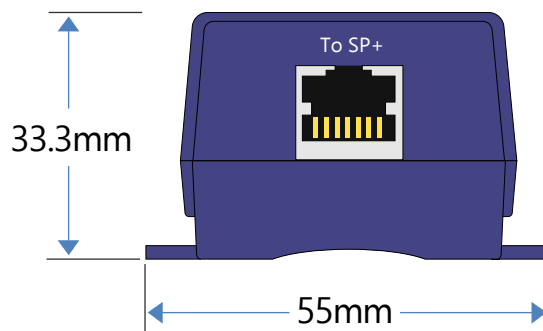
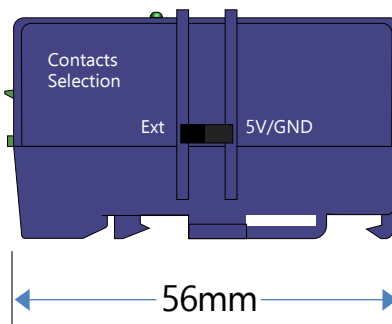
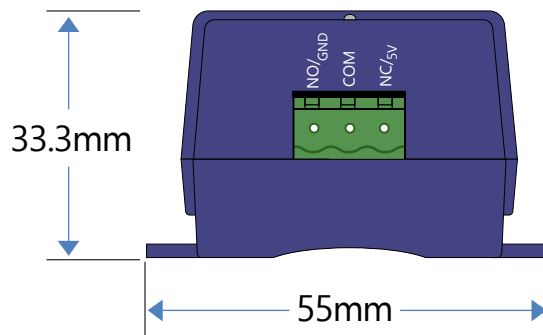
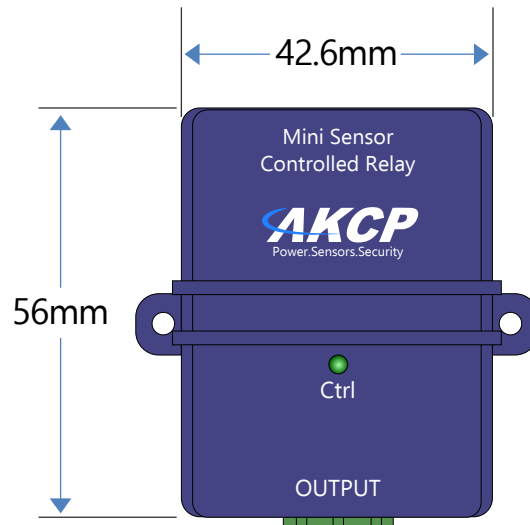

Dry Contact Sensor (DCSxxx)



The Dry Contact sensor is a simple connection to burglar alarms, fire alarms or any application that requires monitoring by the sensorProbe. Dry contact sensors are user definable and can be used to detect many different inputs such as UPS status, security systems, air conditioning status.

These general purpose switches can be either input or output. When used as an output it can source up to 20 mAmps. You can select the output voltage by setting the Output Level to a Low or a High. When set to Low the pin will output 0 volts. When set as a High the pin will output 5 volts. can be sent via an email or SNMP trap.

Technical Specifications

Measurement Range	Input: Alarm or Normal Output : Set or Reset
Sensor Type	Input : Open / Closed contact switch Output : High (5V) / Low (GND)
Contact voltage range	5 volts pulled-up dry contacts*
Input Measurement Rate	Multiple readings every second
	Normal input state is settable under software
Electrical Output	Can sink up to 20mA**, when set to Low
Interface	
Communications Cable	RJ-45 jack to sensor using UTP Cat 5 wire
Communications Cable Max. length	1000Ft (305m) with approved low capacitance shielded cable or UTP
Power Source	Powered by the base unit. No additional power needed
	Full autosense including disconnect alarm
Important Note	*Dry Contacts are not isolated, don't connect any voltage source ** Dry contact output is not suitable for directly driving a relay
Sensor count 1	1

DCSxxx - Technical Drawing

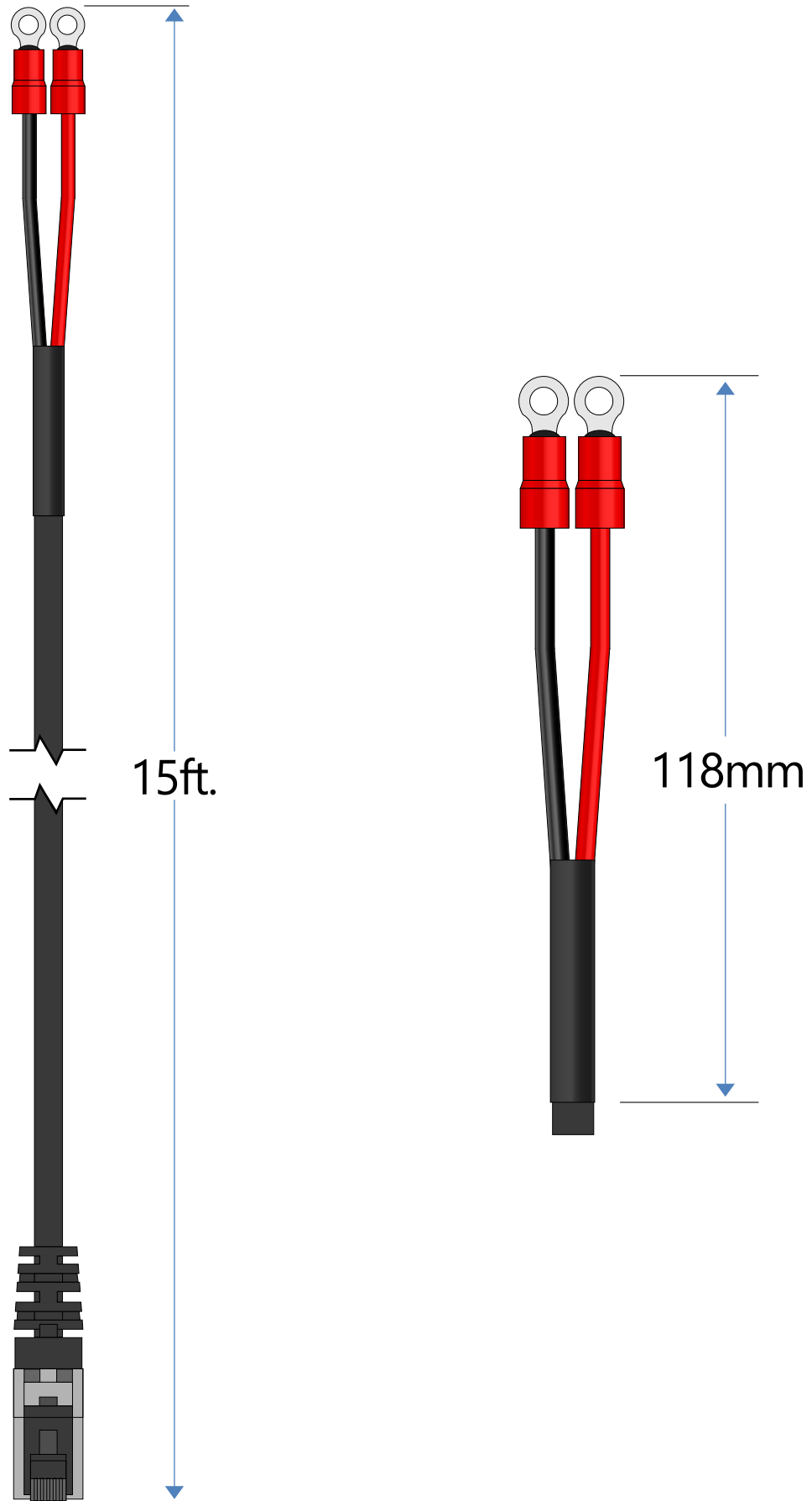

Isolated DC Voltage Sensor (IDCV00)



The Isolated Digital Voltmeter allows the user to integrate a custom sensor to the sensorProbe or securityProbe while still retaining all of the features of the standard sensors. The Digital Voltmeter has the full range of functionality including SNMP integration, email and trap generation upon settable limits and thresholds.

The Isolated DC Voltage Sensor can be used by OEMs and engineers to create their own custom data collection systems. The user can input a DC voltage range from -60 to 0 volts or 0 to 60 volts. The Isolated DC Voltage Sensor can provide real time data from the world around them. Can be sent via an email or SNMP trap.

IDCV00- Technical Specification

Measuring Specifications	
Voltage Input	Selectable Voltage input : ± 0~60 VDC ± 0~5 VDC with 0.001 V resolution and 1% FS accuracy
Status Indication	LED indication for power LED indication for status LED indication for over voltage
Input Impedance :	Input Impedance : 1.6 MOhm when set at the high scale (60 Volt maximum) and 1.1 MOhm when set at the low scale (5 volt maximum)
Isolation Voltage :	1600 VDC
Inputs	2 pin phoenix connector for Voltage measurement Voltage range input selector switch
Components	Manufactured using highly integrated, low power surface mount technology to ensure long term reliability.
Operating Environment	Temperature : Min. -35° C – Max.80° C Humidity: Min. 20% – Max. 80% (Non-Condensing)
Interface	
Communications cable :	RJ-45 jack to sensor using UTP CAT5e/6 cable
Power source :	Power source : Powered by the controller unit. No additional power needed
Power Consumption :	Typical 110 mWatt, 22 mA
Maximum Cable Length:	The iSolated DC Voltage sensor can be extended from the RJ-45 Intelligent Sensor ports on the base units up to 60 feet, or 18 meters using standard CAT5/6 LAN cable
Dimensions	65(W) x 62(H) x 15(D) mm
Mounting	DIN rail mounting
Sensor	Screw mounting
	1

IDCV00 - Technical Drawing

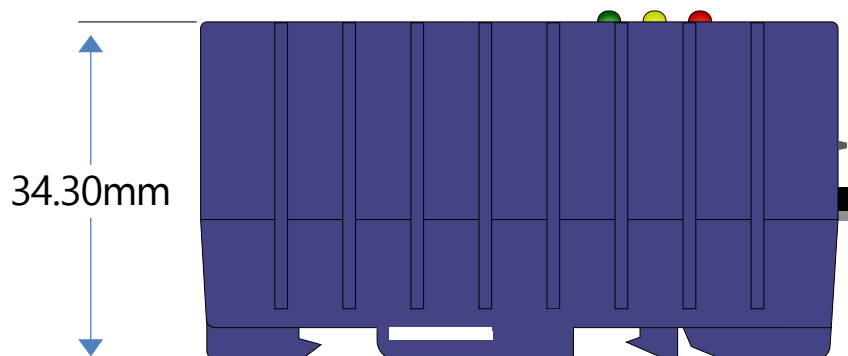
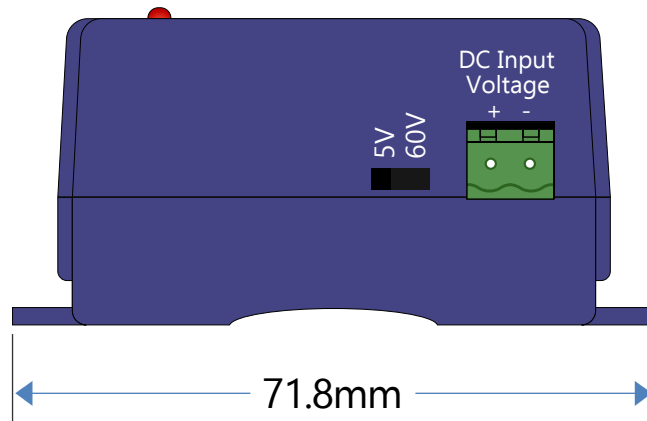
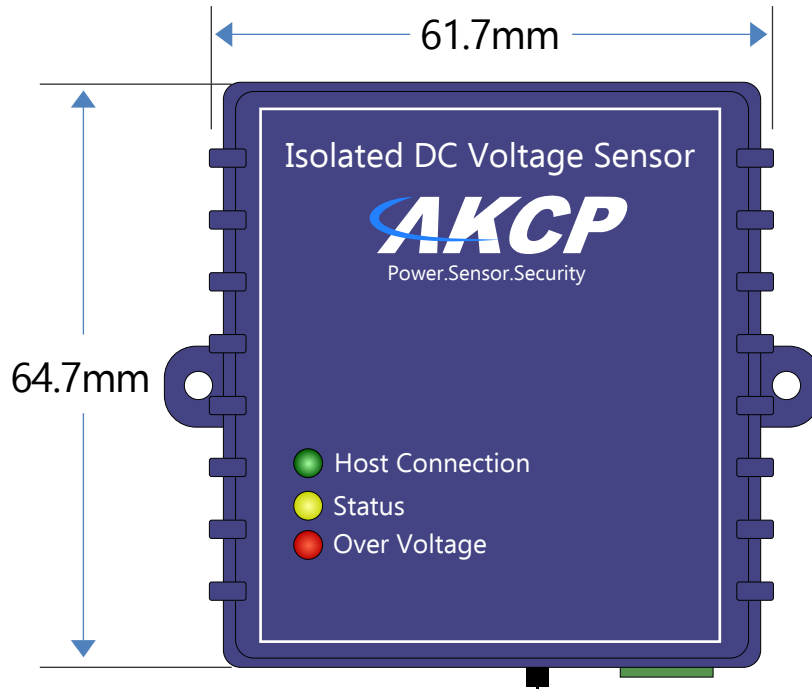

In-Line Power Meter (ILPM)



Power Monitoring and Switching

16A and 32A in-line power meters with optional Relay.

The power meter goes between the electrical source and the PDU or individual appliance, monitoring the voltage (V), current (A) and Kilowatt Hours (kWh) being consumed. Identify power hungry equipment with billable grade accuracy and remotely switch devices on and off. Relays are either Normally Closed, Normally Open or Bi-Stable Latched relay, which retains it's state regardless of whether it is receiving power or not. can be sent via an email or SNMP trap.



In-Line Power Meter (ILPM)

In-Line Power Meter is essential for:

- Checking how close you are to tripping your circuit breaker
- Ensure sufficient power overhead when adding equipment to a circuit
- Billing individual clients in co-located services
- Monitoring up to 16 appliances from a single IP address

Choice of plug types to match your train

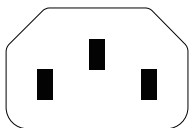

C13 / C14

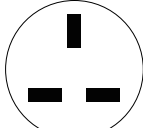

U.K



AUS

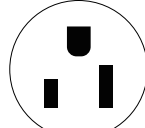

Nema 5-15

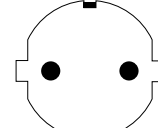

Shuko

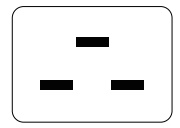

C19 / C20

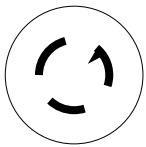

Nema L5-20
Nema L6-30

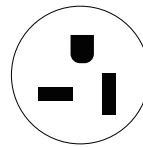

Nema 5-20

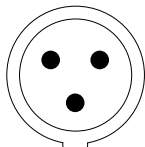

IEC P+N+E

ILPM - Technical Specification

Measurements	
Power Rating	Input Voltage rating: Current Rating : - 1 phase - 16A - 100V~250V AC - 32A
Power Measurements - Voltage (V)	- Voltage (V) - Current (A) - Active Power (kW) - Total Active Energy (kWh) - Leakage current (A) - Power Factor
Environment monitoring	Optional Cabinet Thermal Map (-CTM or -CTHM) - Temperature sensor - Humidity sensor *range -40°C to +75°C * 0 to 100% Relative humidity
Control	
Switching Relay	Latched Relay Contacts rating : 40 Amp Mechanical Life : 1 10 ⁷ times Electrical Life : 3 10 ⁴ times Class B
Status Indication	LED indication for power LED Relay status (with optional relay)
Inputs	1x sensor RJ45 Port Hardwired with following plugs : - IEC 60320 C20 - Nema L5-20P - IEC 60320 C14 - Nema L5-30P - Nema 5-15P - UK BS - Nema 5-20P - Shuko CEE 7/7 plug - Nema 5-30P - IEC60309 2P+E blue - Nema L5-15P
Outputs	Outlet types : - IEC 60320 C13 - Nema L5-20R - IEC 60320 C19 - Nema L5-30R - Nema 5-15R - UK BS1363 - Nema 5-20R - Shuko CEE 7/3 Socket - Nema 5-30R - IEC 60309 2P+E Blue
Interface	
Communications cable	RJ-45 jack to sensor using UTP CAT5e/6 cable
Power source	Powered by the sensorProbe+ family units. No additional power needed
Power Consumption	Typical 800 mWatt, 160 mA
Maximum Cable Length	Peak 1.75 Watt, 350 mA Run length is 32 feet (10 meters) with approved low capacitance shielded cable or UTP
Dimensions	170 x 85 x 52 mm
Mounting	Keyhole mounting
Components	Components Manufactured using highly integrated, low power surface mount technology to ensure long term reliability.
Operating Environment	Temperature : Min. -35° C – Max.80° C Humidity: Min. 20% – Max. 80% (Non-Condensing)
MTBF	1,400,000 Hours based on field experience with sensorProbe units.
Important Note	sensorProbe+ units auto detects the presence of the ILPM sensor - The ILPM sensor is only compatible with the sensorProbe+ platform units. - When plugging the first time or after upgrading a sensorProbe+ unit, the sensor's firmware might be upgraded by the unit and not be available right away. - On the sensorProbeX+, the sensor can be used only on the main module sensor ports
Sensor count	ILPM : 5 -CTM : +9 ILPM-LR : 6 -CTHM : +11

ILPM - Technical Specification

Options and Product Codes

In-line Power Meters come with a variety of options, relays, thermal maps, connection types. Refer to the table below for the available options.

Order individual code options, or combine into a single part number:-

16A In-line Power Meter with Latched Relay

ILPM-16A-LR or **ILPM-16A LR**

Product Name	Product Code
Inline Power Meter 32A (25cm Power in/out cable bare ends)	ILPM-32A
Inline Power Meter 32A (25cm Power in/out cable bare ends)	ILPM-16A
Options	
Relays	
Normally Closed Relay	NCR
Normally Open Relay	NOR
Latched Relay	LR
Cabinet Thermal Maps	
Cabinet Thermal Map Temperature Only	ILPM-CTM
Cabinet Thermal Map Temperature & Humidity	ILPM-CTHM
10A Connections	
IEC C13 (Power Out)	C13
IEC C13 Locking (Power Out)	C13L
IEC C14 (Power In)	C14
13A Connections	
UK Plug (Power In)	UKP
15A Connections	
AUS (Power In)	UKP
Nema 5-15R (Power Out)	5-15R
Nema 5-15P (Power In)	5-15P

Product Name	Product Code
16A Connections	
EUR Plug (Power In)	EURP
C19 (Power Out)	C19
C19 Locking (Power Out)	C19L
C20 (Power Out)	C20
IEC 2P+E (Power In)	2PEP
IEC 2P+E (Power Out)	2PEO
20A Connections	
Nema 5-20R (Power In)	5-20R
Nema L6-20P (Power Out)	L6-20P
Nema 5-20P (Power Out)	5-20P
30A Connections	
Nema 5-30P (Power Out)	5-30P
Nema L6-30P (Power Out)	L6-30P
32A Connections	
IEC 2P+E (220v Power In)	2PEP-32
IEC 2P+E (220v Power Out)	2PEO-32

ILPM - Technical Drawing

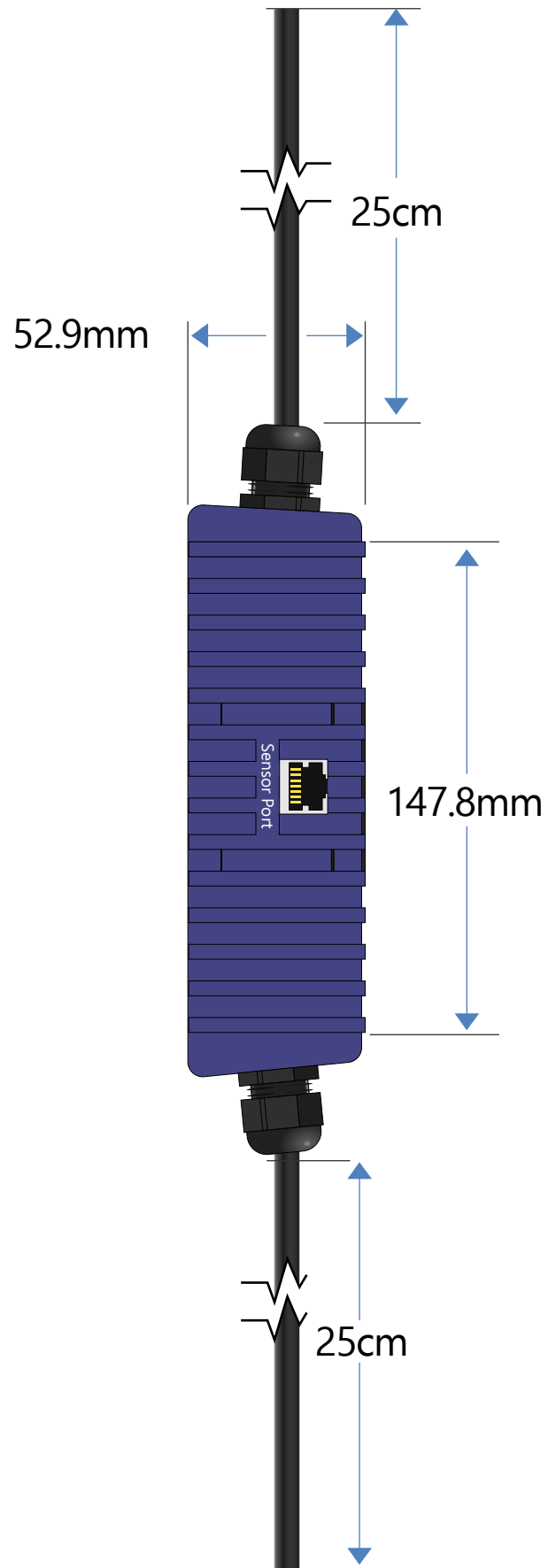
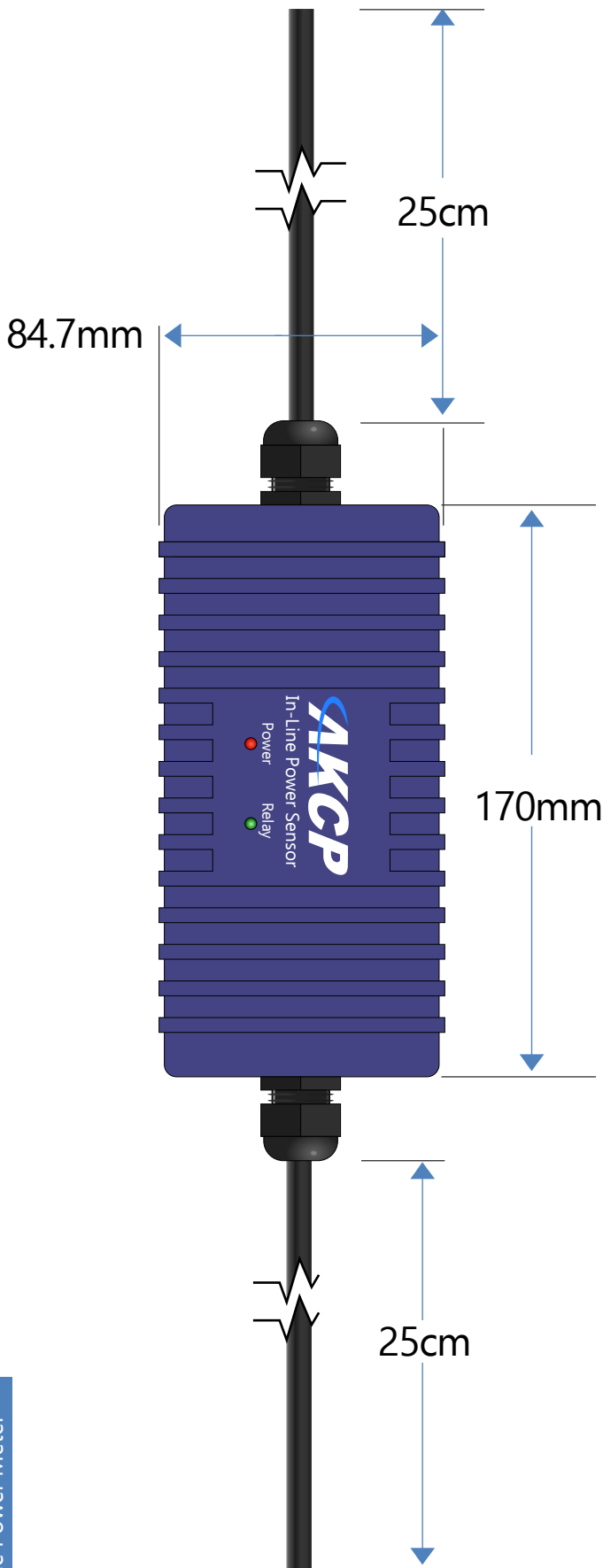

Power Monitoring Sensor (PMS)



The AKCP Power Monitor Sensor gives vital information and allows you to remotely monitor power eliminating the need for manual power audits as well as providing immediate alerts to potential problems.

It has been integrated into the base unit web interface with its own "Power Management" menu, allowing up to six three phase and fourteen single phase Power Monitor Sensors to be set up on a single securityProbe or SPX+. More PMS can be connected to a single base unit depending on what readings are required.

Data collected over time using the Power Monitor sensor can also be viewed using the built in graphing tool. Combining this durable Power Monitor Sensor with the SPX+ or securityProbe base unit creates an IP-enabled power monitoring capable of monitoring:

- Phase Line Voltages
- Current
- Power Factor
- Active Energy
- Active Power

ILPM - Technical Diagram

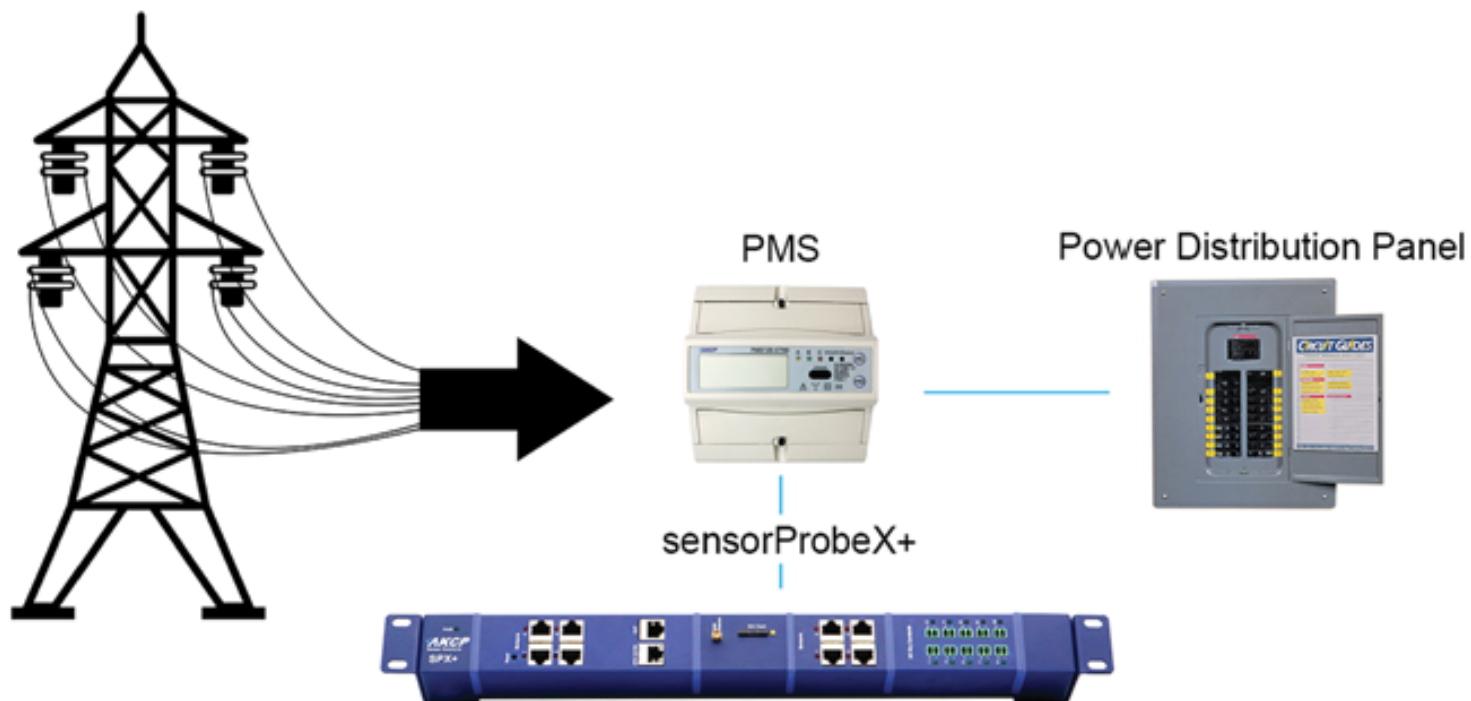

PMS - Technical Specification

Voltage (V)			
Rated Voltage (Un)	230V AC	230/400V AC (3")	230/400V AC (3")
Operational Voltage Range	0.7~1.3Un	161/279-300/520V AC (3")	161/279-300/520V AC (3")
Current (A)			
Basic Current (b)	10A	10A	1.5A
Maximum Current	100A	100A	6A
Operational Current Range	0.4% ib-Imax	0.4% Ib- Imax	0.4% Ib- Imax
Over Current Withstand	30Imax	30Imax for 0.1s	30Imax for 0.01s
Internal Power Consumption	≤2W / 10VA	≤2W/10VA per phase	≤2W/10VA per phase
Frequency			
Operational Frequency Range	5-60Hz ±10%	50Hz ±10%	50Hz ±10%
Operating Environment			
Operating humidity	<75%	<75%	<75%
Operating temperature	-10°C - +50°C	-10°C - +50°C	-10°C - +50°C
International standard	IEC 62053-21	IEC 62053-21	IEC 62053-21
Accuracy Class			
Voltage	±0.5%	±0.5%	±0.5%
Amps	±0.5%	±0.5%	±0.5%
Frequency (Hz)	±0.2%	±0.2%	±0.2%
Dimensions			
Height	100 mm	130mm	130mm
Width	76 mm	126mm	126mm
Depth	65.5 mm	65mm	65mm
Max Diameter Cable	11.5 mm		
Weight	0.35 Kg	0.7 Kg (net)	0.7 Kg (net)

PMS - Technical Drawing

Single Phase

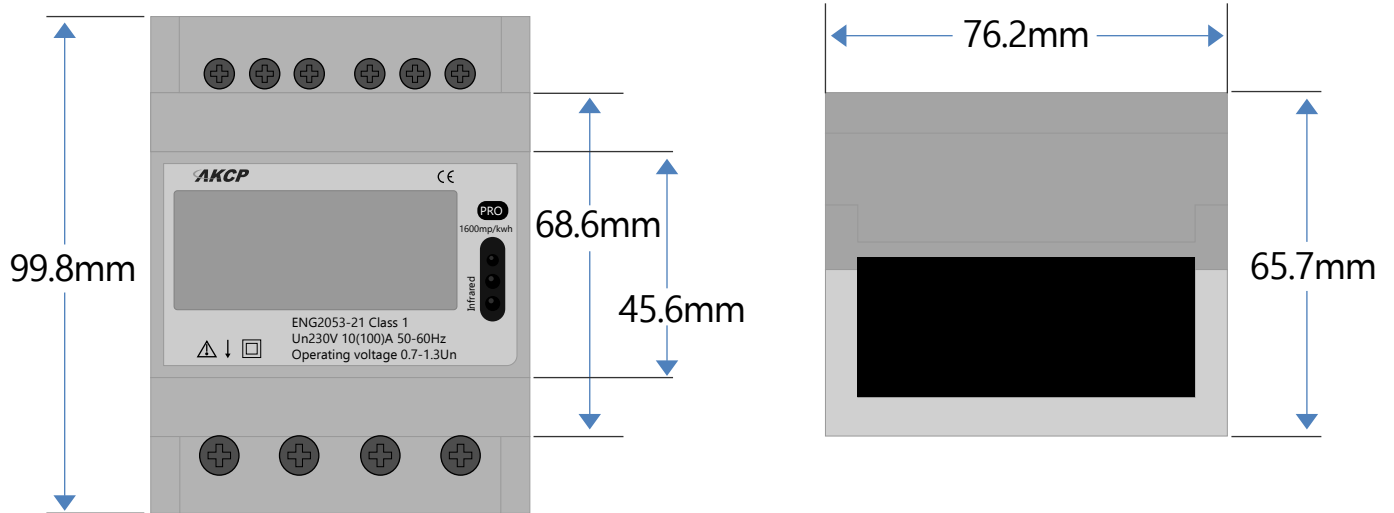

Three Phase

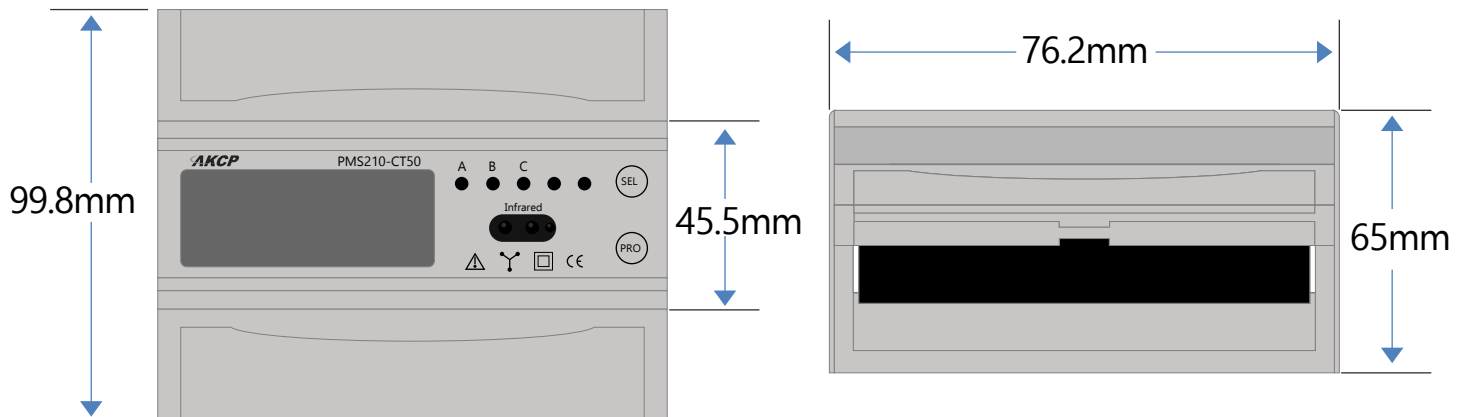

Current Transformers (CTXXX/5A)



AKCess Pro Current Transformers are designed for easy installation with a simple, fast, safe and easy way to connect a monitoring system to your power supply.

- Sensing Overload Currents
- Ground fault detection
- Metering
- Analog to Digital circuits
- Facilities and building management

AKCess Pro provide split core current transformers that can be installed without opening any cable or bus bar circuit. The connection of conventional Current Transformers (CTs) usually requires the interruption of the primary side circuit to pass cables or bus bars through the transformer core or to connect such cables to the primary terminals.

The AKCess Pro transformers core can be easily opened and installed then connected without any supply interruption. AKCess Pro Current Transformers save you time and installation costs and are safer to work with:

- Compact size for easy mounting
- Wide inner window, allowing clamping of big cables or bus bars
- Wide range of sizes to accommodate all existing installations
- High accuracy and reliability

CTXXX/5A - Technical Drawing

The CT's connect with our Current Transformer Power Meter which is compatible with securityProbe and sensorProbe+ platforms.

Primary Current Range	100A-5000A
Secondary Current	5A,1A
Standard approval :	IEC44-1, BS7626
Maximum voltage :	0.72/3Kv
Frequency :	50/60Hz
Rated load :	1VA-30VA
Class :	0.5, 1.0, 3.0
Short-time thermal current :	1th=100xIn
Rated security coefficient :	FS<5

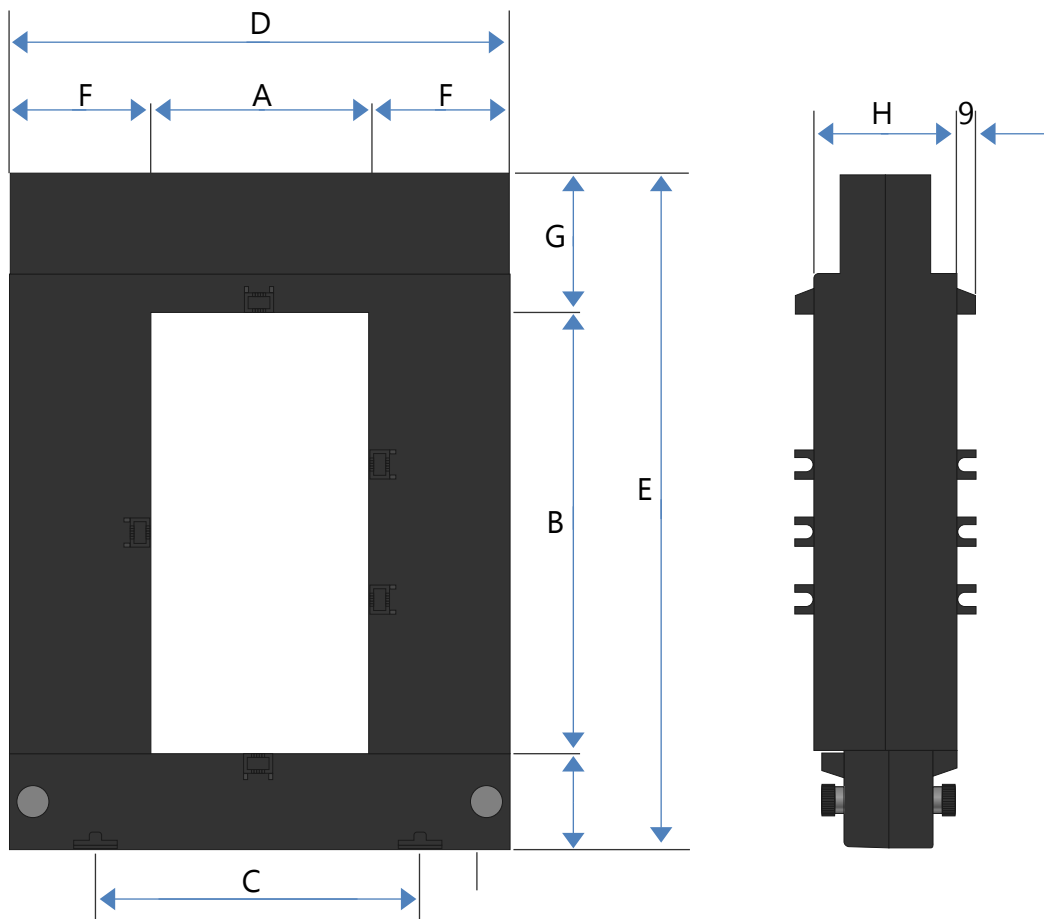

Model	A	B	C	D	E	F	G	H	I	Weight (kg)
DP-23	20	30	51	89	111	34	47	40	32	0.75
DP-58	50	80	78	114	145	32	32	32	33	0.90
DP-88	80	80	108	144	145	32	32	32	33	1.05
DP-812	80	120	108	144	185	32	32	32	33	1.25
DP-816	80	160	120	184	245	52	52	52	38	4.3

Current Transformers (CTXXX/5V)



The CTXXX/5V current transformers feature a 0-5 VDC scale output. For those who do not need full power monitoring, these CT's connect directly to the A2D input module on the SPX+, or with the wireless A2D adapter.

The CT's come in a variety of sizes for different current ranges.

- 5A - 50A
- 10A - 100A
- 100A - 300A
- 100A - 500A

The accuracy of the CT is consistent at 2% of full scale.

Split core CT are easy to install as no wires need disconnecting. Simply clamp it around the load you wish to measure.

Primary Current Rating	5-500A
Output Voltage	1-5VDC
Maximum Voltage	720V
Frequency	50/60Hz
Communications cable	2 wire cable to A2D input on SP+ or Wireless Tunnel Module
Operating Environment	Temperature : Min. 25° C – Max.60° C Humidity: Min. 20% – Max. 80% (Non-Condensing)

CTXXX/5V - Technical Drawing

5A - 50A Technical Drawing

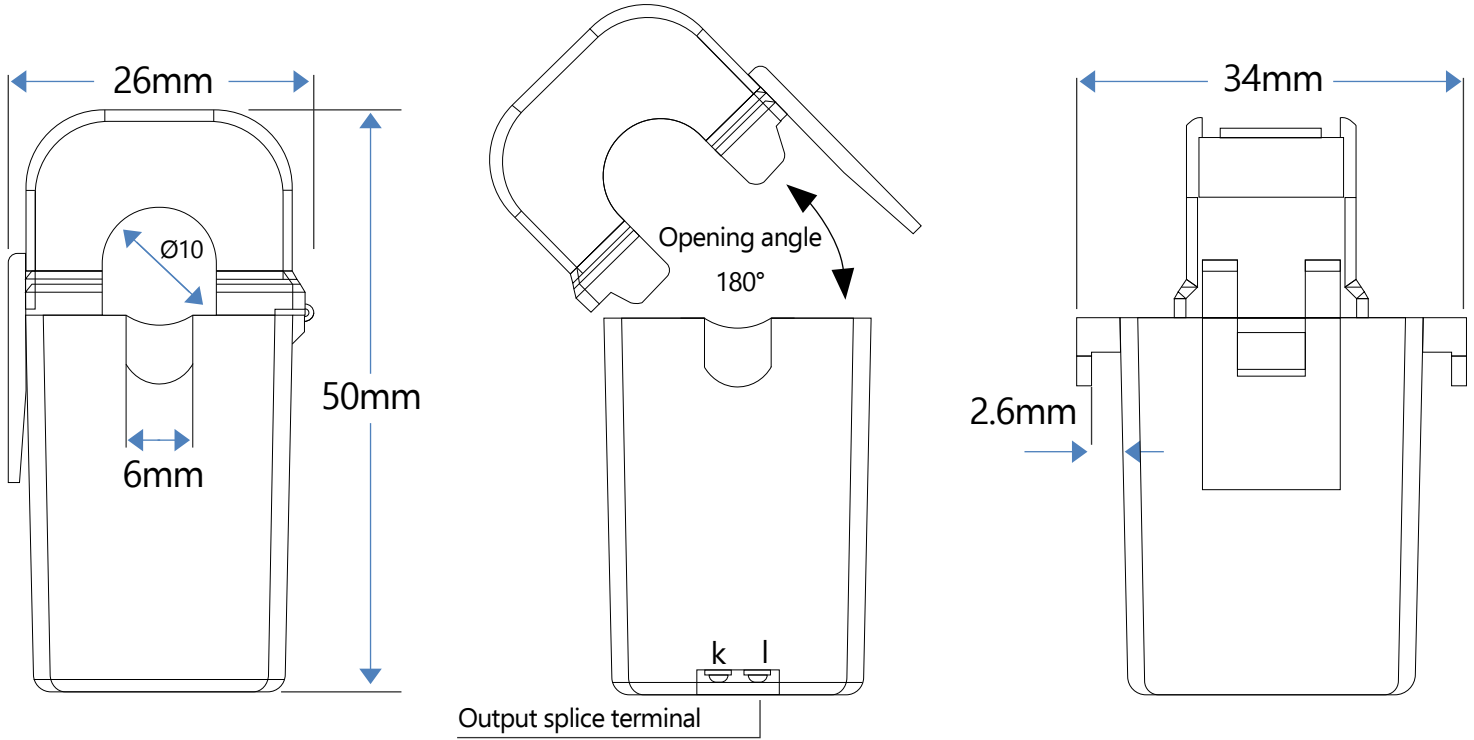

10A - 100A Technical Drawing

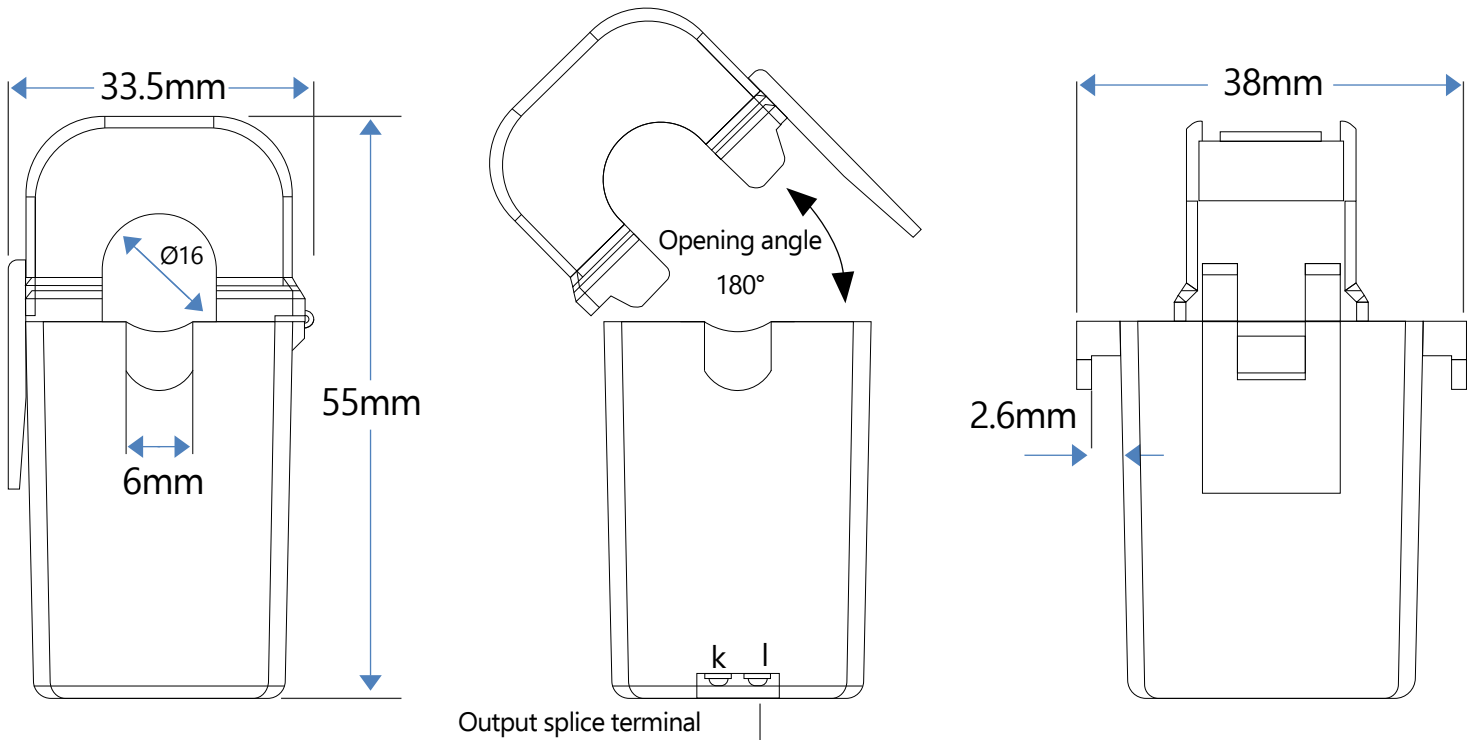

CTXXX/5V - Technical Drawinga

100A - 300A Technical Drawing

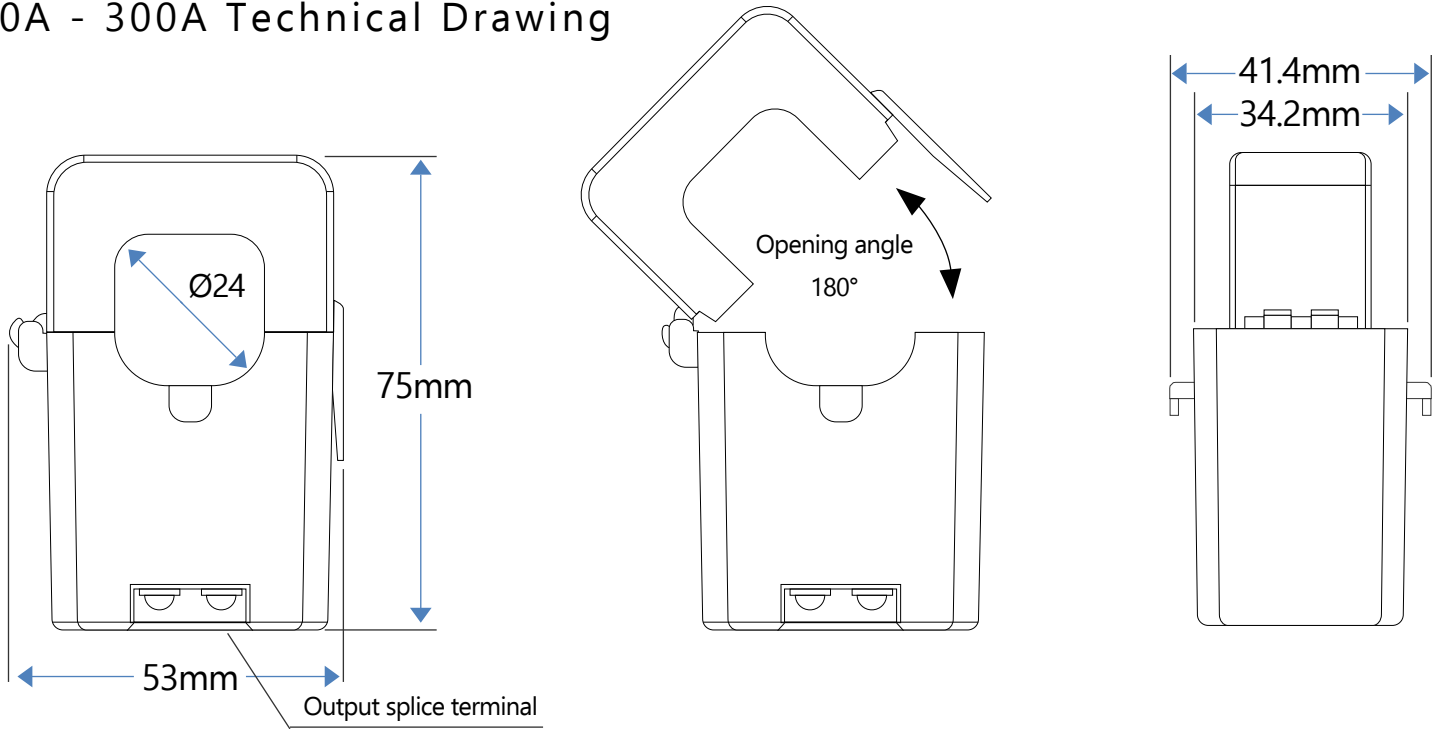

100A - 500A Technical Drawing

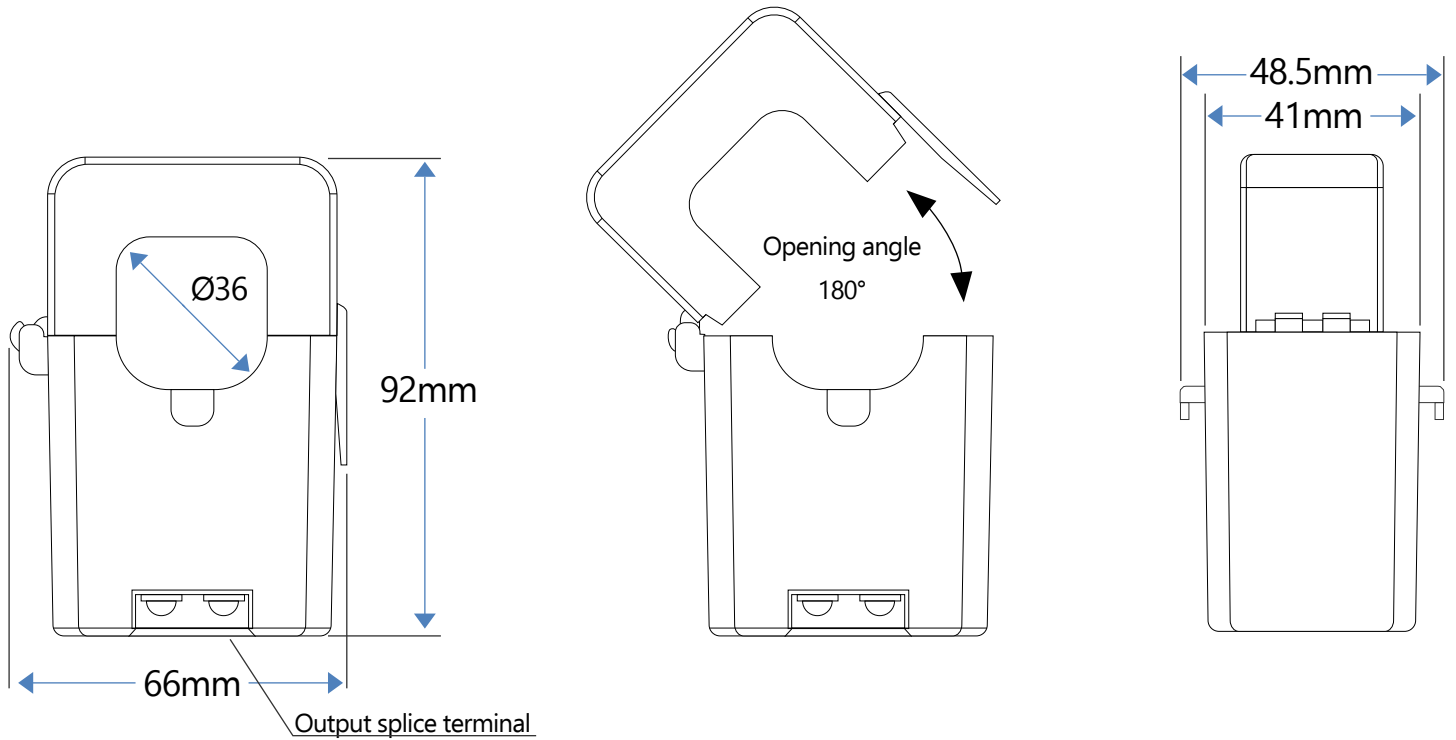

Battery Monitoring Sensor (BATTMON)



Monitor DC Voltage and Current.

The Battery Monitoring Sensor is a simple, yet effective way to monitor a variety of battery types. Lead Acid, LiPoly, individual cells or banks of batteries. The sensor consists of a battery terminal temperature sensor

battery DC Voltage meter and a current transformer. Check the battery system performance, such as charge/discharge status. This sensor aids in maintaining and monitoring battery health for generators and engines, backup UPS power and solar systems.

Note: Correctly sized CT must be ordered with the BATTMON. CT value is set in production and can't be changed.

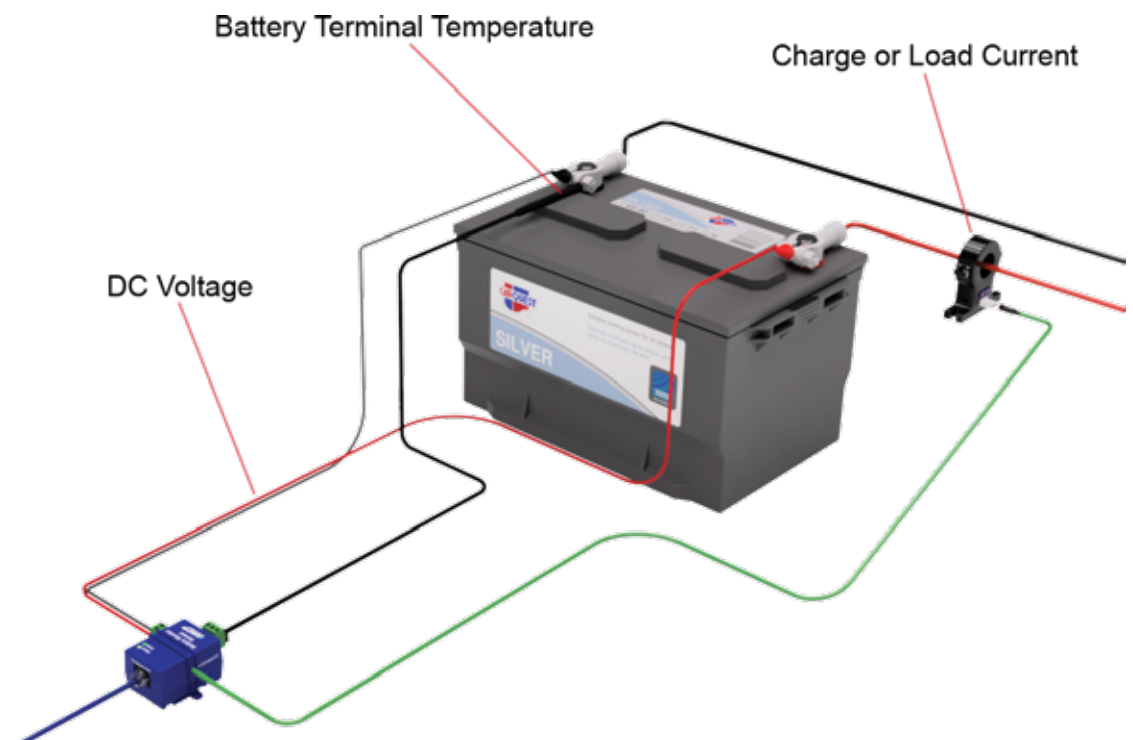

BATTMON - Engines and Generators

Monitor Starter Motors and Alternators

Connect the BATTMON sensor to your generator/engine battery to monitor the voltage, terminal temperature and either the crank current from the starter motor or the charge current from alternator.

Crank Current By monitoring the crank current you can identify decrease in battery performance. Decreasing current during crank can be a sign of bad battery health, or problems in the starter motor. This can lead to a failure to start situation.

Charge Current Place the CT on the Alternator to monitor charge performance and identify early signs of alternator or electrical system problems.

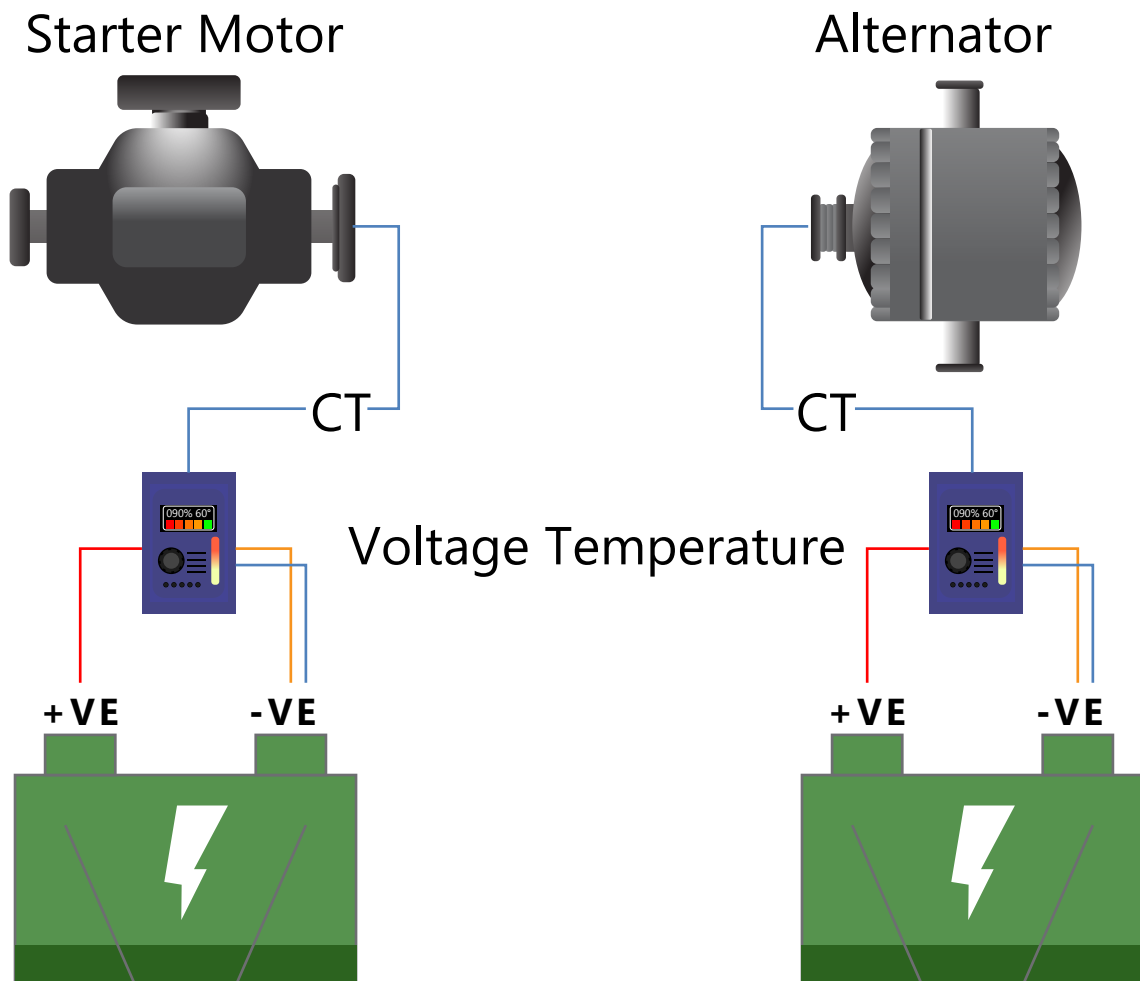

BATTMON - Solar Panels and Battery Stacks

Solar System Monitoring

BATTMON can be installed on a solar panel battery system. Monitor individual cell voltages, temperature and current, or voltage and temperature only. Place a single CT on the battery stack to monitor the load. An additional CT placed on the solar panel output gives a complete end to end monitoring of your charging current, battery load, cell voltages and temperatures.

- Check your solar panel efficiency, voltage and current outputs.
- Monitoring individual cells and complete battery stacks
- Monitoring charge current vs discharge current

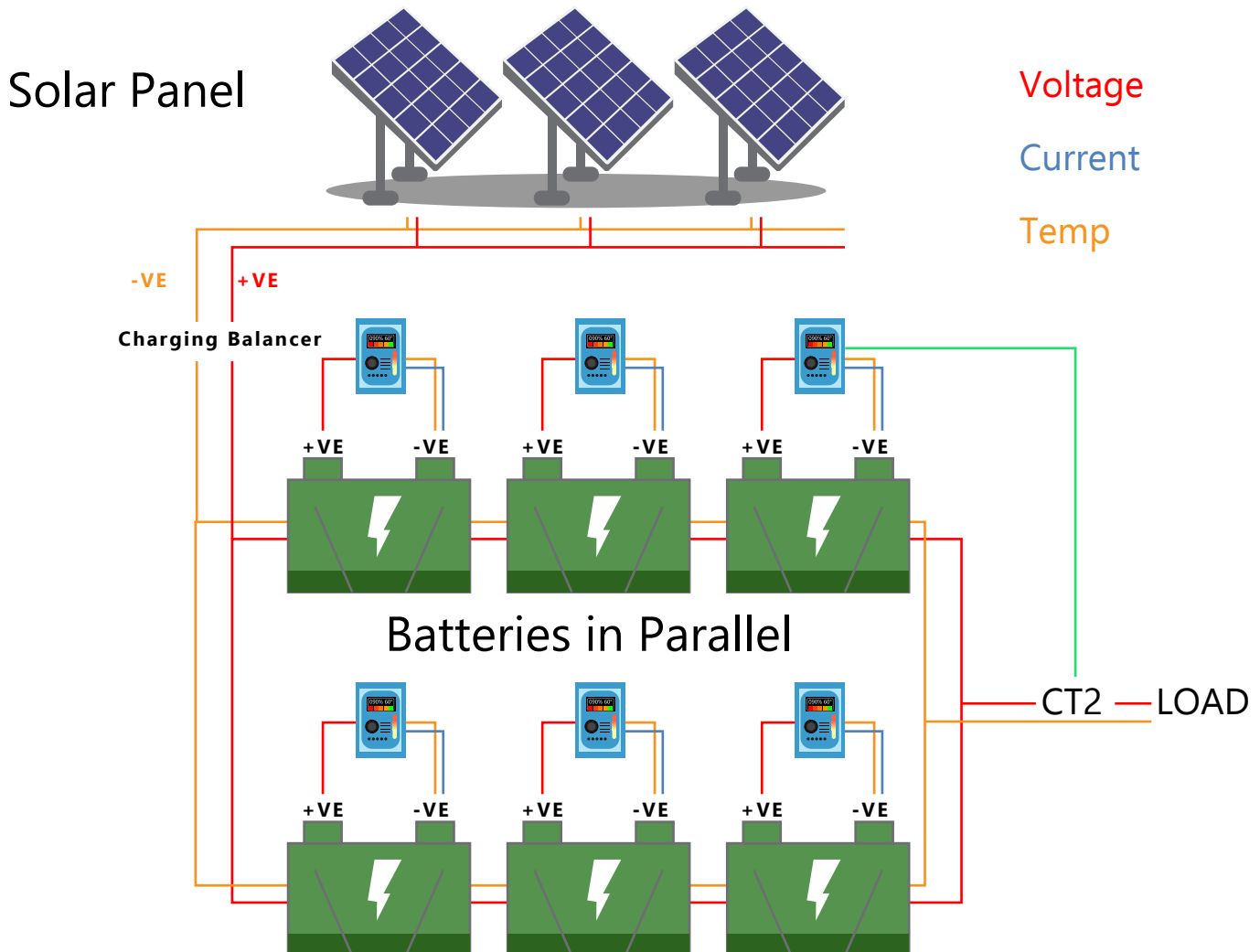

BATTMON - Solar Panels and Battery Stacks

Solar Panel

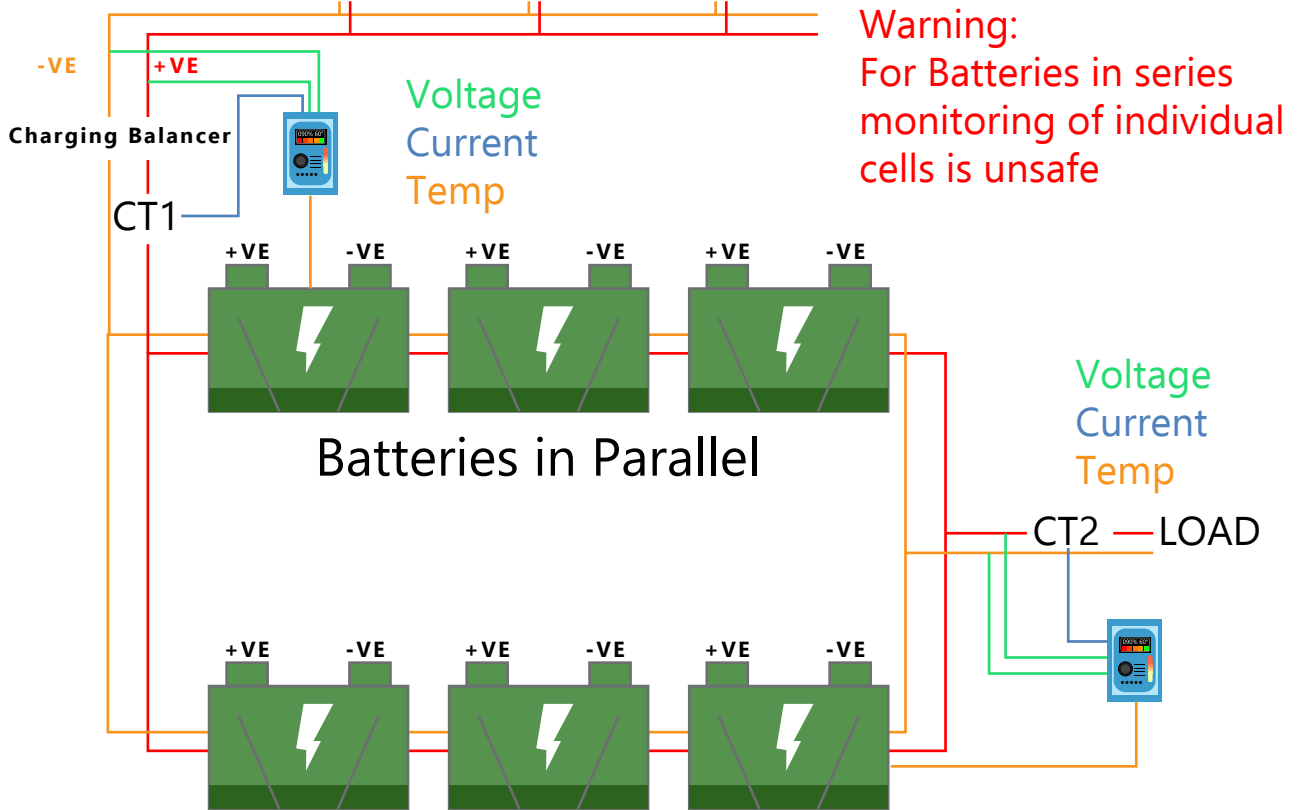
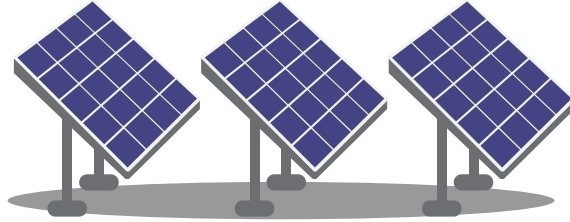

BATTMON - Technical Specification

Measurements	Measurements
Power Rating	<p>Power Rating Input Voltage and Current ratings :</p> <p>Voltage: 0~60VDC (3 configurable ranges : 0~15V, 0~30V or 0~60V)</p> <p>Current: DC current via external CT</p> <ul style="list-style-type: none"> + 50A (standard) + 100A + 200A + 400A + 500A + 600A + 800A + 1000A + 1500A + 2000A
Power Measurements	<ul style="list-style-type: none"> - Voltage (V) : +/-0.05% Full-Scale, error +/-0.05% Full-Scale - Current (A) : +/-0.05% Full-Scale, error +/-0.05% Full-Scale, Temperature Drift : +/-0.02%/°C - Power (W) : +/-0.05% resolution
Environment monitoring	<ul style="list-style-type: none"> - Temperature sensor with 1 meter cable <p>*range -40°C to +75°C</p>
Status Indication	<p>LED indication for power</p> <p>LED indication for input presence</p>
Inputs	<p>1x sensor RJ45 Port</p> <p>Hardwired with following plugs :</p> <ul style="list-style-type: none"> - Phoenix connector for voltage - Phoenix connector for temperature - Phoenix connector for external current transformer
Interface	
Communications cable	RJ-45 jack to sensor using UTP CAT5e/6 cable
Power source	Powered by the sensorProbe+ family units. No additional power needed
Power Consumption	
Maximum Cable Length	Run length is 32 feet (10 meters) with approved low capacitance shielded cable or UTP
Dimensions	56 x 55 x 33.3 mm
Mounting	<p>DIN rail mounting</p> <p>Screw mounting</p>
Components	Manufactured using highly integrated, low power surface mount technology to ensure long term reliability.
Operating Environment	<p>Temperature : Min. -35° C – Max.80° C</p> <p>Humidity: Min. 20% – Max. 80% (Non-Condensing)</p>
MTBF	1,400,000 Hours based on field experience with sensorProbe units.
Important Note:	<p>the BattMon sensor is not galvanically isolated, care must be taken regarding possible differential voltage potential issues</p> <ul style="list-style-type: none"> - The BattMon sensor is only compatible with the sensorProbe+ platform units. - When plugging the first time or after upgrading a sensorProbe+ unit, the sensor's firmware might be upgraded by the unit and not be available right away. - Smart sensor upgrade can only be performed on the main 4 sensor ports of the SP+ - Correctly sized CT must be ordered with the BATTMON. CT size is set in production and can't be changed.
Sensor Count	4

BATTMON - Technical Drawing

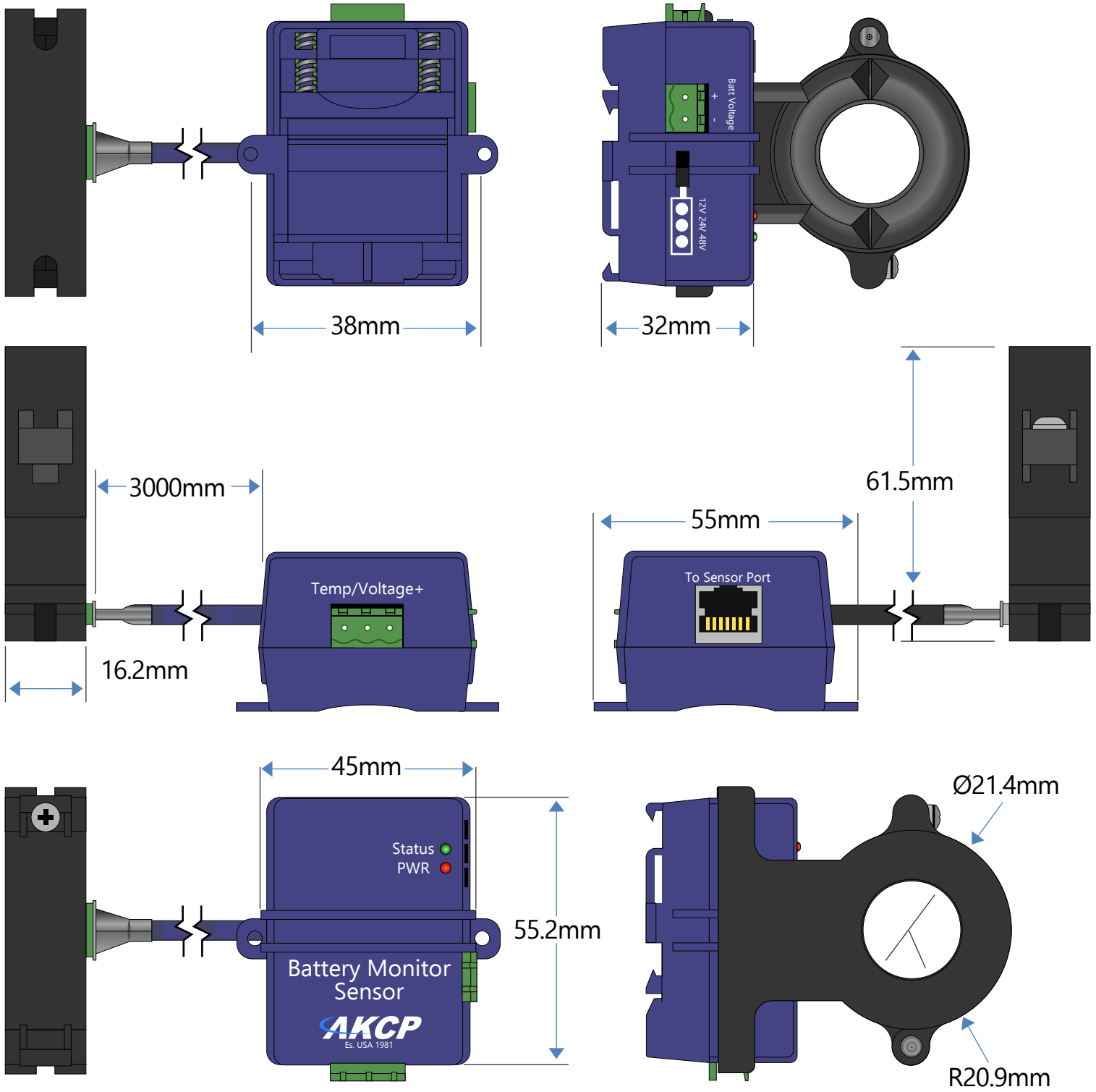

Contactless Current Meter (CCM)

Monitor Current Without Cutting Wires

Most current transformers require you to have access to an individual wire. This is not practical where you have the live, neutral and earth wires in a single sheath. The AKCP Non-Invasive current meter allows you to monitor current (and power if you have a reference voltage) in 2 core or 3 core cables. Our unique current measurement technology makes measuring individual IT rack current and power simpler, and lower cost than ever before.

Combine the Non-Invasive current meter with cabinet thermal map sensors. Using our AKCPro Server combine current load, thermal map and differential air pressure and analysis. analysis.

Benefits

- No downtime for installation
- No electrician required
- Input for PUE calculations
- Rack level current monitoring
- Accurate +/- 5%
- Input for AKCP sensorCFD

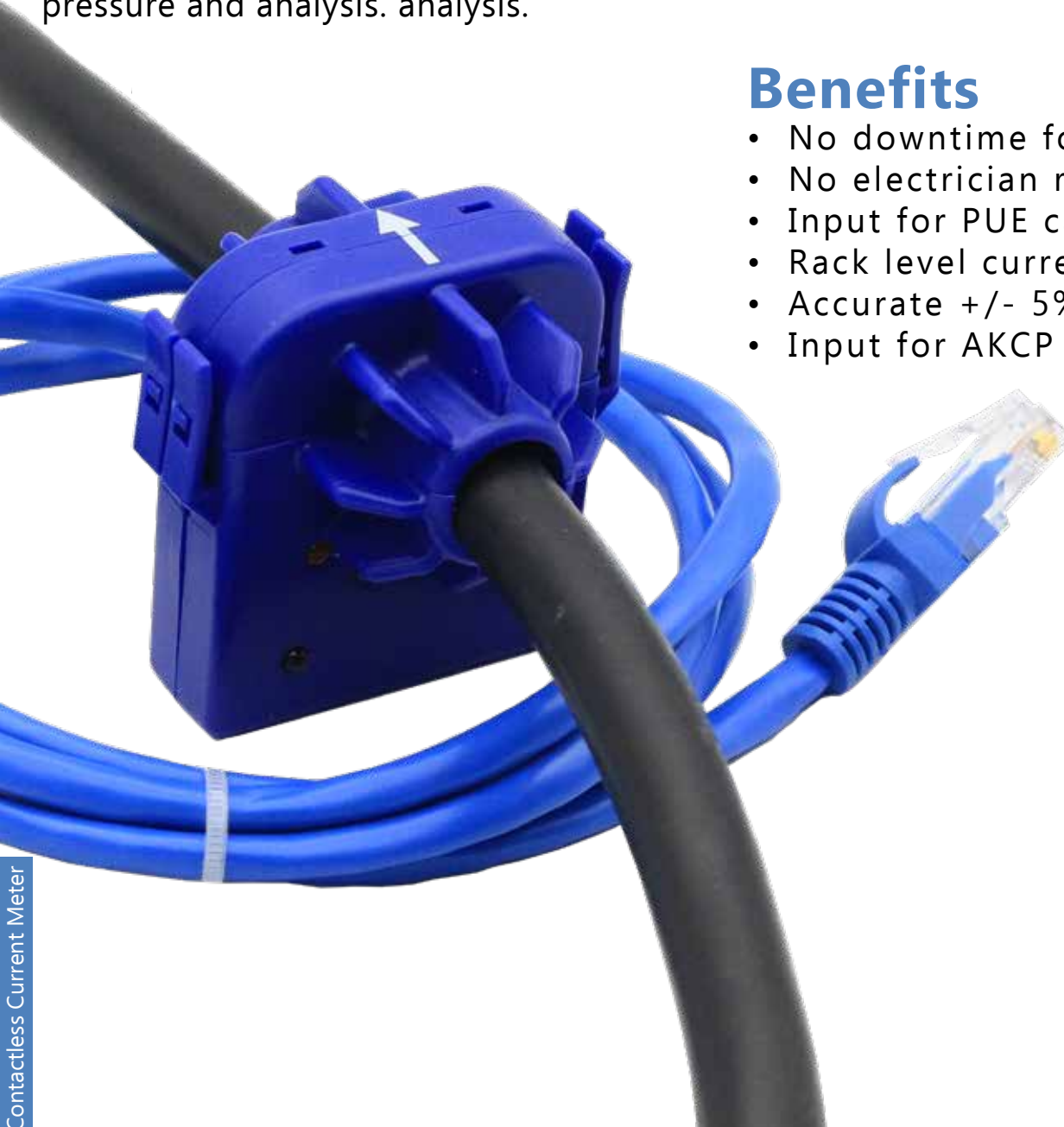

CCM - Technical Specification

Measuring Specifications	
Status Indication	LED indication for power LED array for calibration
Inputs	Magnetic field sensing of current in multicore cable
Accuracy	+/- 5% when factory calibrated on cable of same type +/- 10% on non-factory calibrated cable
Components	Manufactured using highly integrated, low power surface mount technology to ensure long term reliability.
Operating Environment	Temperature: Min. -35° C – Max.80° C Humidity: Min. 20% – Max. 80% (Non-Condensing)
Interface	
Communications cable :	RJ-45 jack to sensor using UTP CAT5e cable
Power source :	Powered by the controller unit. No additional power needed
Power Consumption :	Typical 7.25mWatt, 1.45mA
Maximum Cable Length :	Maximum Cable Length : 50ft using standard CAT5/6 UTP cable
Dimensions	49(W) x 45(H) x 51(D) mm
Mounting	Mounting Cable Mounted
Sensor count	1

CCM - Technical Drawing

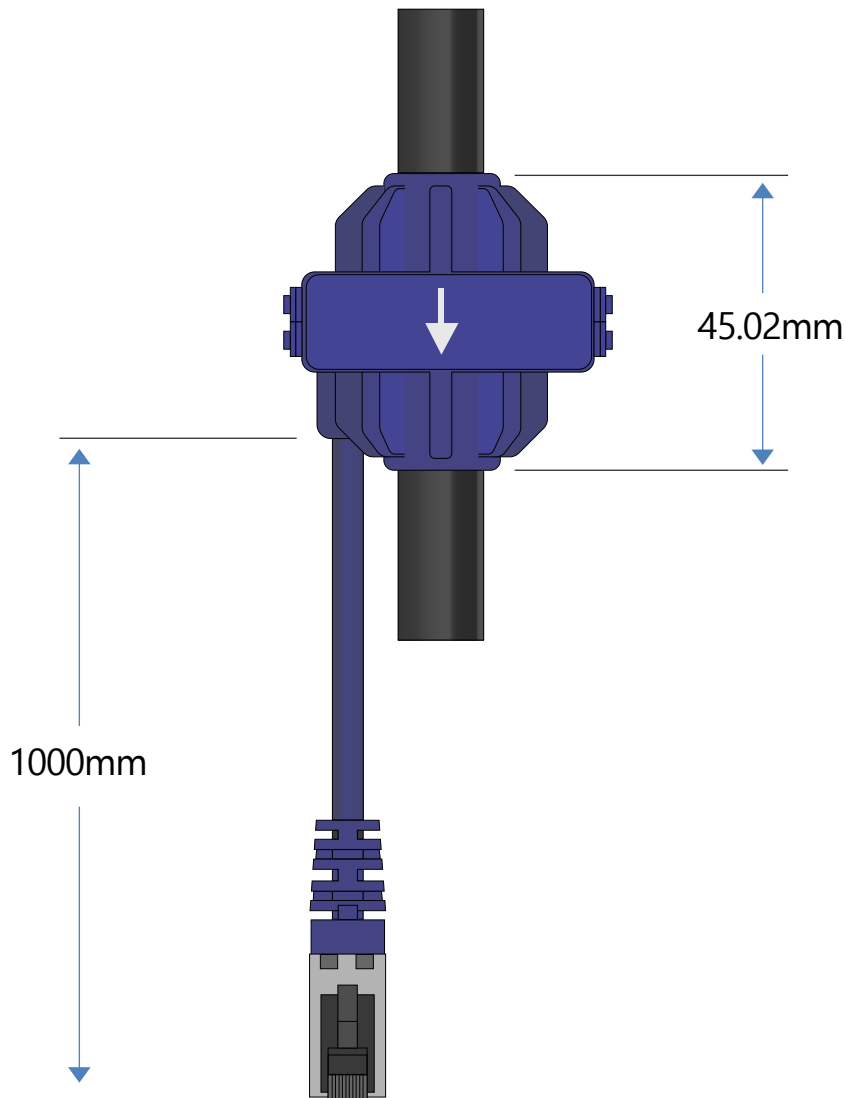
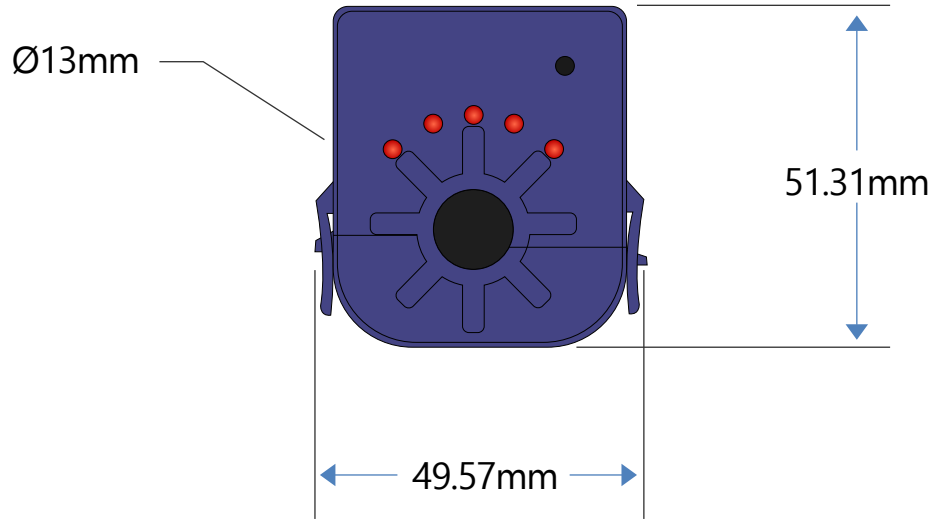

Specialized Sensor



Sensor Adapter



Modbus Adapter



probeSwitch



LCD Display



Battery Terminal
Temp Sensor



Tank Depth Pressure
Sensor



ropeFuel Sensor

LCD Display (LCD-TMP)



Programmable display of sensor values

The AKCP LCD Sensor Display plugs into any sensorProbe+ (SP2+, SPX+) base unit and can be programmed to display the data from any AKCP Intelligent or virtual sensor. Mount a single display on the end of an aisle, on the door of every cabinet, or the wall of the room. LED indicators will alert if a sensor is in critical condition, as well as the on screen display of the critical or warning status.

Features

- Easy to read, high quality backlit LCD display
- Connects to available sensor port on sensorProbe+
- Program to display specific sensors
- Keyhole mounting
- LED Status indicator

LCD-TMP - Technical Specifications

Temperature	
Measurement Range	-40°C to +75°C -40°F to +167°F
Measurement Resolution	0.1°C increments 0.2°F increments
Measurement Accuracy	Maximum ±0.3 at -40°C, minimum ±0.3 at +25°C and ±0.3 at +75°C Maximum ±0.6 at -40°F, minimum ±0.6 at +25°C and ±0.6 at +167°F
DISPLAY	
LCD Display data	Continuous embedded temperature display Display up to 8 sensors in standard rotation list, configured via SP+ web interface with preview.
	Display sensor status, Warning or Critical Display sensor units: °C, °F, %rh, %, V, (mA), (kW), (kWh) Display unit's IP address when plugged in Display swing handle lock status: Open, Closed Blue backlight
LCD size	88.95 x 53.42 mm
LED Indicator	2 global status LEDs : Warning and Critical status
Interface	
Communications cable	RJ-45 jack to sensor using UTP CAT5e/6 cable
Power source	Powered by the sensorProbe+ family units. No additional power needed
Power Consumption	Typical 220 mWatt, 40 mA
Maximum Cable Length	Run length is 30 feet (10 meters) with approved low capacitance shielded cable or UTP
Dimensions	169.67 x 97.1 x 31.18 mm
Mounting	Keyhole mounting
Important Note	The Programmable LCD Sensor Display is only compatible with the sensorProbe+ platform units. - When plugging the first time or after upgrading a sensorProbe+ unit, the sensor firmware might be upgraded by the unit and not be available right away. - On the sensorProbeX+, the sensor firmware can be upgraded only on the main module sensor ports
Sensor	1

LCD Display - Technical Drawing

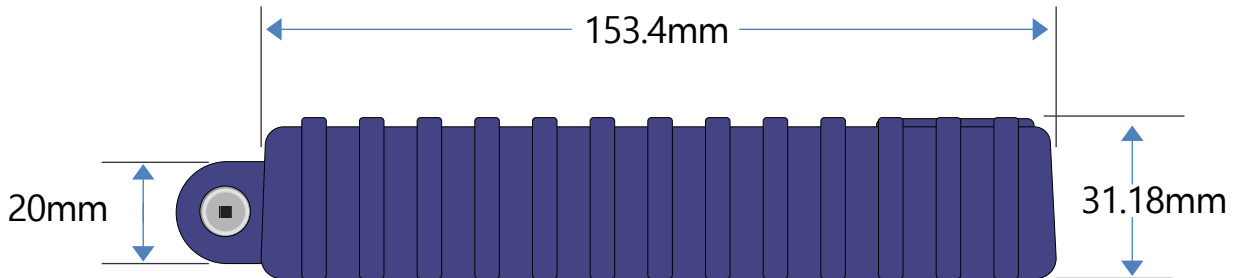
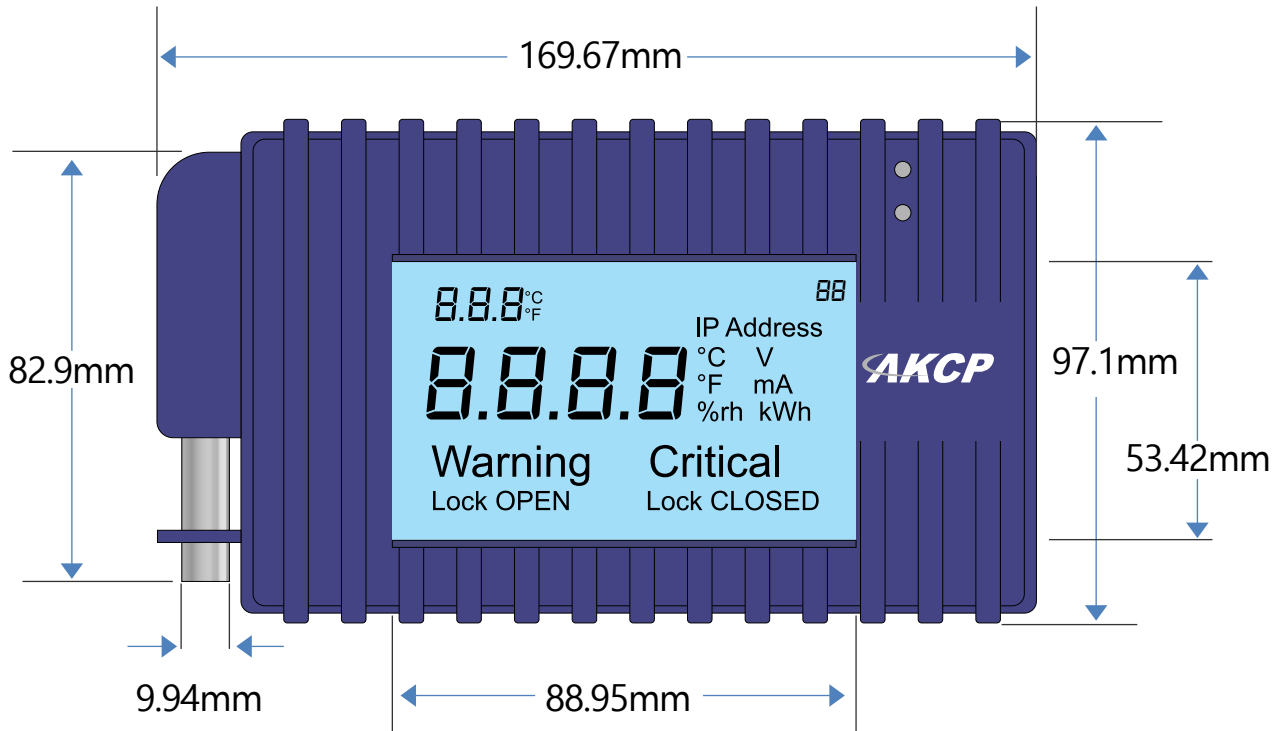

LCD 45° Mounting Bracket

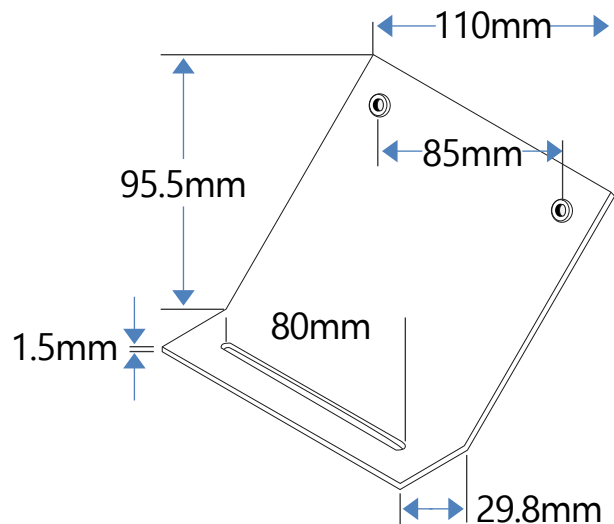
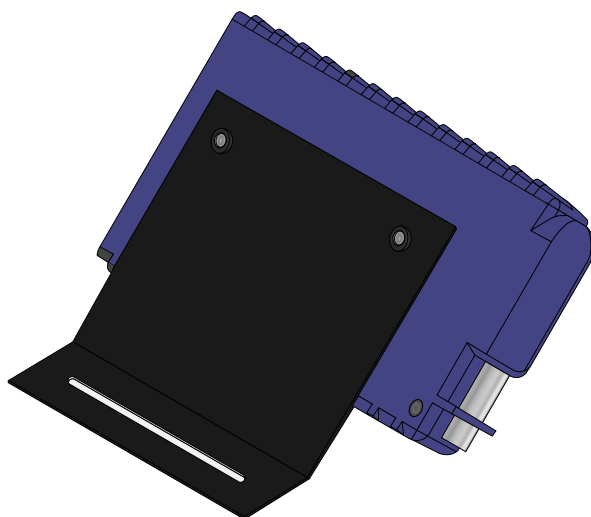

Tank Depth Pressure Sensor (TDPS-5/10/15)

The tank depth pressure sensor can monitor all types of fuel and other liquid storage tanks. Comes complete with all mounting hardware required.

Lower the sensor into the tank until it reaches the bottom, and connect it with the sensorProbe+ device. The sensor will detect the pressure of the liquid column above it and calculate the depth of the liquid based on this. TDPS are available calibrated for different tank depths from 5 to 15 meters.

TDPS-5 (For 5 meter tank)

TDPS-10 (For 10 meter tank)

TDPS-15 (For 15 meter tank)

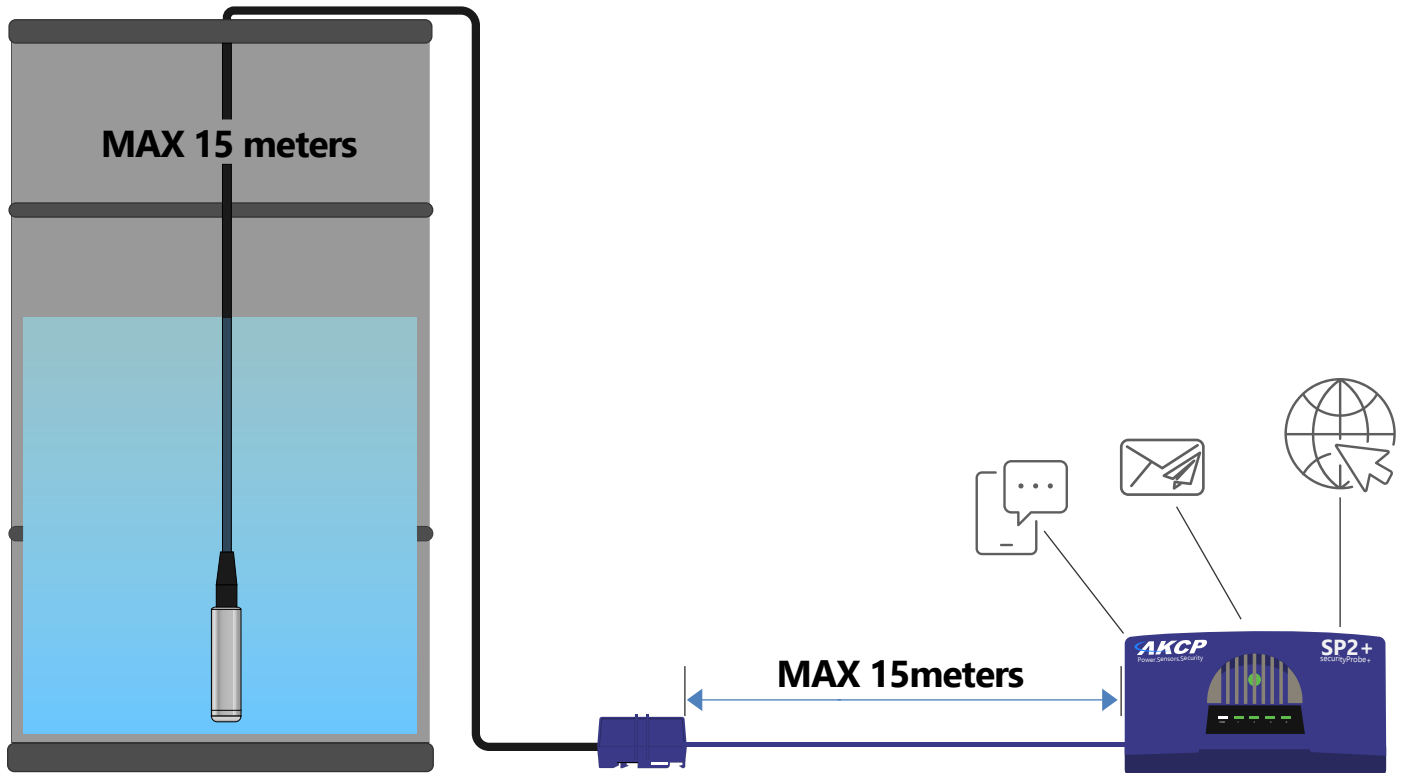

TDPS - Technical Specification

MEASUREMENTS	
Measurement Method	Method Hydraulic Pressure in mH2O (Fluid column pressure)
Tank Depth	(Max) 0–20 m (65 ft) for Water at 4C
Accuracy	Distance 0–2000 cm (65 ft) with 1% accuracy for water
Full Scale Accuracy	± 1%FS (Max)
ENVIRONMENTAL	
Chemical Resistance	Petrol, Diesel, Water
Operating Temperature	Range -20°C to 80°C
Protection Grade	IP68 (pressure sensor part)
Communications cable	RJ-45 jack to Converter module using UTP CAT5e/6 cable
Power source	Powered by the controller unit. No additional power needed
Power Consumption	Typical 25 mWatt, 5 mA
Maximum Cable Length	The Tank level sensor can be extended from the RJ-45 Intelligent Sensor ports on the base units up to 100 feet, or 30 meters using standard CAT5/6 LAN cable. Ships with a 15 foot CAT6 LAN extension cable
Probe Part Cable	Leader cable from the sensor part to the converter box is 5/10/15 meters respectively based on depth type ordered.
	Comes fully assembled, only needs installation
Dimensions	56 x 55 x 33.3 mm
Mounting	DIN rail mounting
	Screw mounting
Notes	Works with certain types of fuel, fresh water
	Works on securityProbe 5E, E-Sensor8 expansion module or sensorProbe+
Sensor count	1

TDPS - Technical Drawing

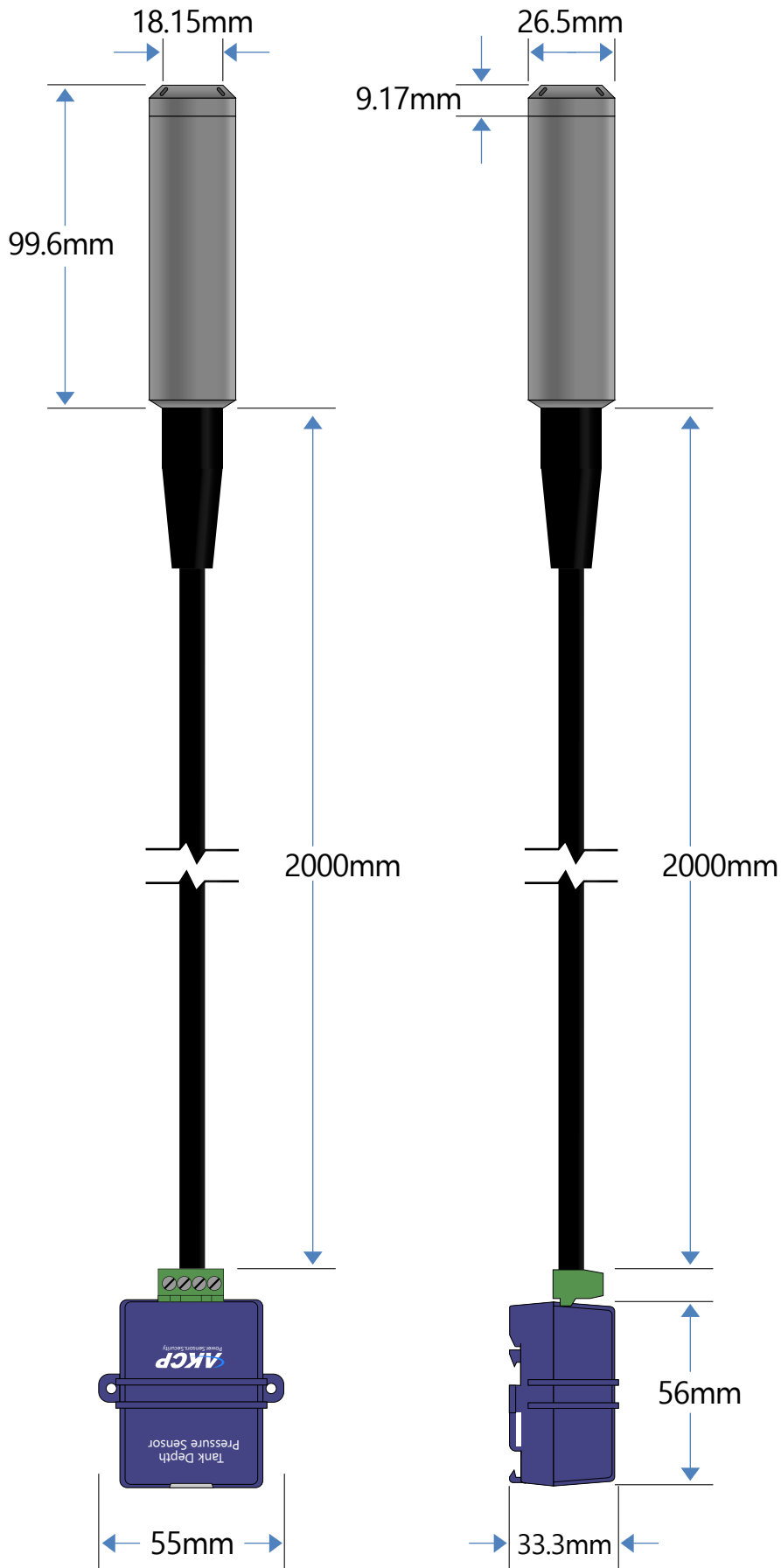

ropeFuel Sensor (FLKS)



The AKCP ropeFuel sensor is a rope-type leak detector that connects to any AKCP sensorProbe or securityProbe RJ-45 Intelligent Sensor Ports and facilitates the detection of fuel and other liquids. The AKPP rope Fuel sensor provides distributed leak detection for a wide range of applications such as monitoring for fuel leaks beneath or around backup generator fuel tanks, fuel storage areas, or fuel transfer stations.

Fuel and Oil Leak Detection

The ropeFuel sensor detects the presence of liquid hydrocarbon fuels at any point along its length. Installed with the AKCPro sensor module, the sensor detects the liquid, triggers an alarm, and pinpoints the location of a leak within a meter, or a foot. Typically this sensor can detect:

- Gasoline
- Diesel #1
- JetA\B\5\8
- JP-4\5\7
- Kerosene

Technical Diagram

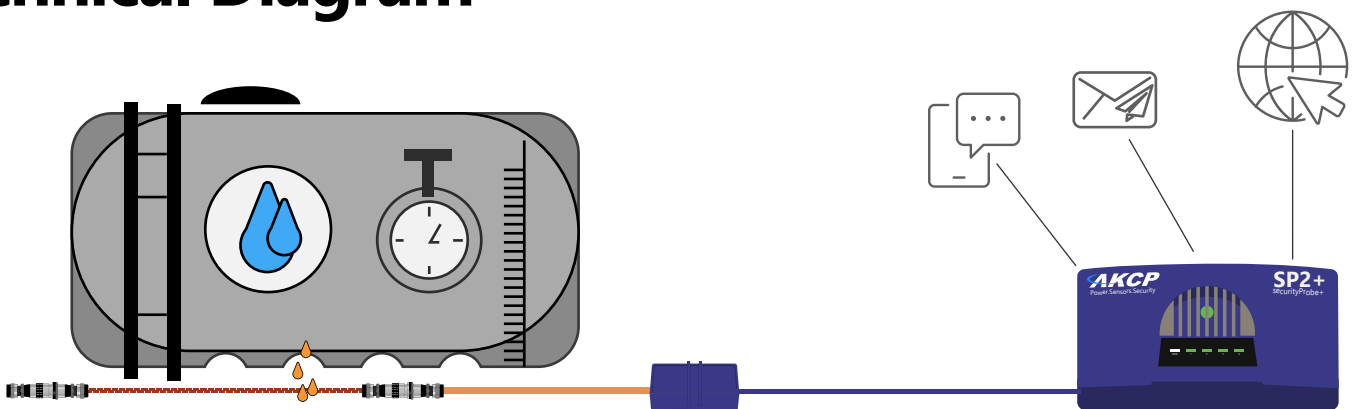

ropeFuel Sensor

FLKS - Technical Specification

Measurement Range	Wet or Dry
Sensor Type	Open/Closed contact input switch
Measurement Rate	Multiple readings every second
	Capable of detecting the presence of fuel and oil at a specific location within 1 meter, or 1 foot along the length of the sensing rope
Response Time	<p>Typical response time at 20°C (68°F)</p> <ul style="list-style-type: none"> • Gasoline : 2-12 minutes (depending on the grade and type) • Diesel #1 : 60 minutes • Jet A\B\5\8 : 50 – 70 minutes • JP-4\5\7 : 15 - 70 minutes • Kerosene : 47 minutes
Nonresettable	Must be replaced after exposure to hydrocarbon liquids
Indication	LED for Status
Operating Temperature	-20 °C~60 °C 4 °F~140 °F
Pull Force Limit	Not to exceed 50 lb
Bend Radius	2 in. (50 mm) minimum
Pressure	Loads greater than 20 lb (9 kg) per linear inch at 20°C (68°F) may immediately trigger analarm
Interface	Interface
Communications Cable	RJ-45 jack to sensor using UTP Cat 5 wire
Communications Cable Max. length	<p>The FuelRope Sensor can be extended from the RJ-45 Intelligent Sensor ports on the base units up to 100 feet, or 30 meters using standard CAT5/6 LAN cable.</p> <p>Comes fully assembled and includes the rope portion that is the liquid sensing cable, the non-sensing leader cable (from the rope to the sensing module) and the main sensing module. Also includes a 5 foot CAT5 extension cable</p> <p>Sensing Rope Cable can be pre-ordered from a 1 meter minimum to any custom run length of up to 5 meters.</p> <p>Non-sensing cable comes in a standard 20 feet run length.</p>
Power Source	Powered by the controller unit. No additional power needed
	Full autosense including disconnect alarm
Power Consumption	Typical 125 mWatt, 25 mA
Dimensions	56 x 55 x 33.3 mm
Mounting	DIN rail mounting Screw mounting
Cable Diameter	0.28 in. (7 mm) nominal.
Important Note	<p>* The AKCP ropeFuel sensor in most cases is for single usage only and must be replaced after exposure to hydrocarbon liquids.</p> <p>* AKCP does not recommend the ropeFuel Sensor to be placed on a conductive surface.</p>
Sensor count	1

FLKS - Technical Drawing

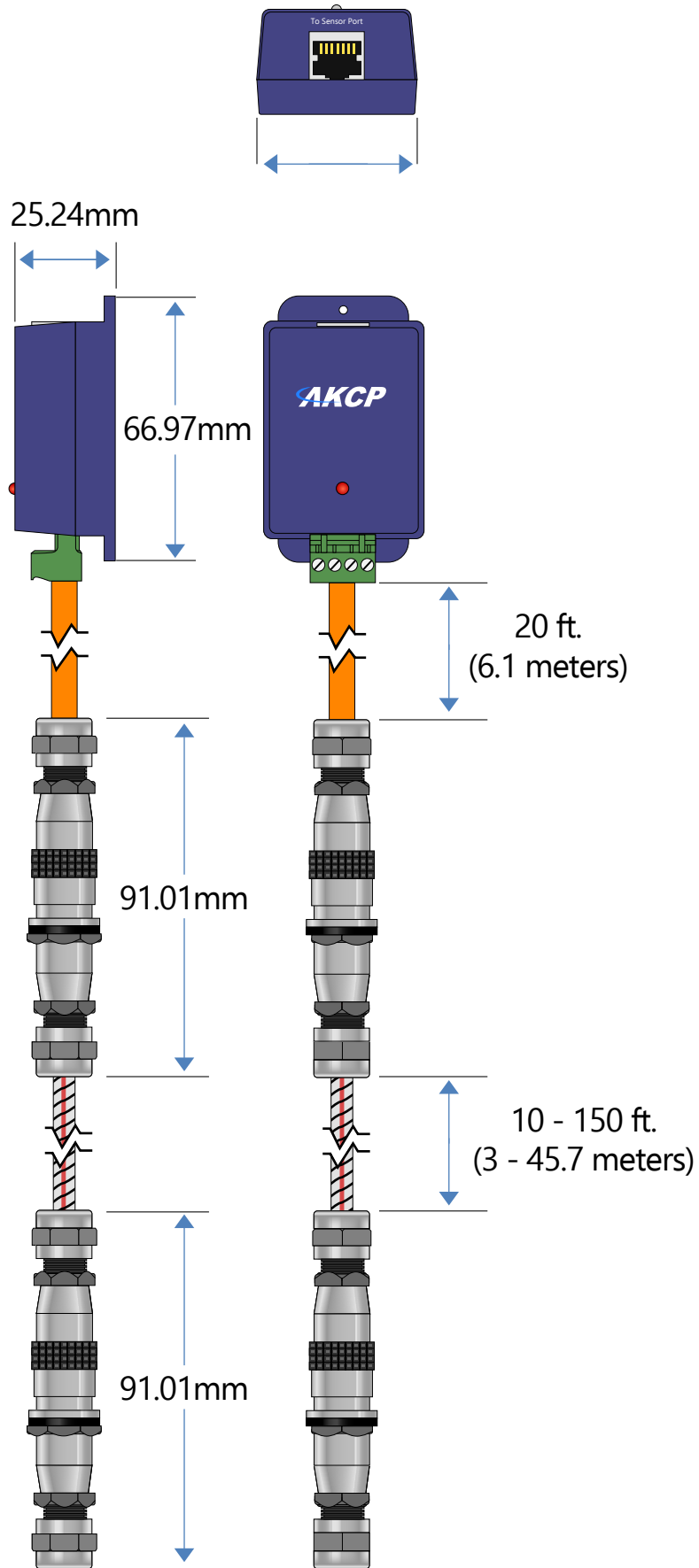

Battery Terminal Temp Sensor (BTTS)



Designed to easily connect to battery terminals, the BTTS connects directly to the Negative Battery Terminal and provide readings to aid in monitoring the battery health, and internal temperature. As the battery terminal provides the closest thermal connection to the batteries internal plates it will give you the closest accuracy to the actual battery temperature. The sensor chip is insulated to help protect it from interference from ambient temperature fluctuations.

Technical Specifications

Temperature	
Measurement Range	-55°C to +75°C -67°F to +167°F
Measurement Resolution	securityProbe and sensorProbe+ series 0.1°C increments 0.2°F increments sensorProbe series 1°C increments 1°F increments
Measurement Accuracy	sensorProbe+ series and securityProbe series ±0.5°C accuracy from -10°C to +75°C ±0.9°F accuracy from +14°F to +167°F sensorProbe series ±1°C accuracy from -10°C to +75°C ±1°F accuracy from +14°F to +167°F
Interface	
Communications cable	RJ-45 jack to sensor using UTP CAT5e/6 cable
Power source	Powered by the base units. No additional power needed
Power Consumption	Typical 7.25mWatt, 1.45mA
Maximum Cable Length	Run length is 1000 feet (300 meters) with low capacitance shielded cable or UTP
Sensor type	Semiconductor, microprocessor controlled
Dimensions	56 x 55 x 33.3 mm
Mounting	DIN rail mounting Screw mounting
Sensor count	1

BTTS - Technical Drawing

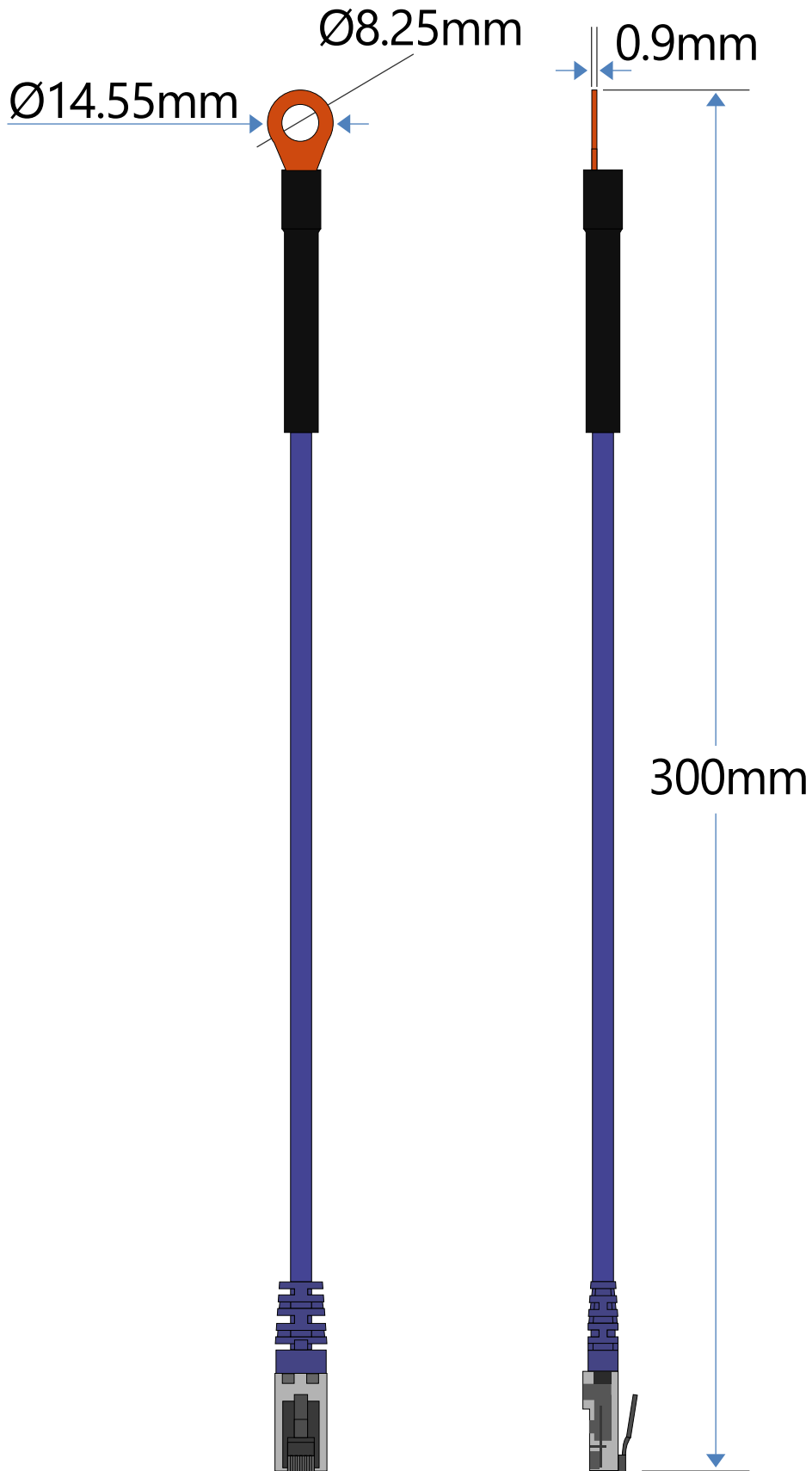

probeSwitch (PS00)



Carry out maintenance on areas that would normally trigger unnecessary multiple notifications. With this new product it is now possible to turn off all notifications with a simple turn of a key switch. This product can be connected to the securityProbe Series as a dry contact and once set up is ready to work. Once connected there is no need to disable the notifications using the web interface, your maintenance engineer simply turns the switch connected to the unit, to turn off the notifications and when they have completed their work just switch the notifications back on.

Technical Specifications

Measurement Range	Alarm or Normal
Sensor Type	Open / Closed Key Lock Switch
Indicator	LED for connection LED for status
Interface	Interface
Communications Cable	RJ-45 jack to sensor using UTP Cat 5 wire
Communications Cable	1000Ft (305m) with approved low capacitance shielded cable or UTP
Power Source	Powered by the base unit. No additional power needed Full autosense including disconnect alarm
Dimensions	56 x 55 x 33.3 mm
Mounting	DIN rail mounting Screw mounting
Important Note	* Auto-sensed as Dry Contact

PS00 - Technical Drawing

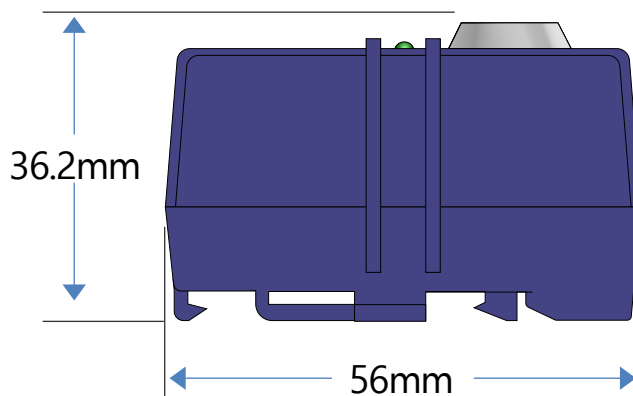
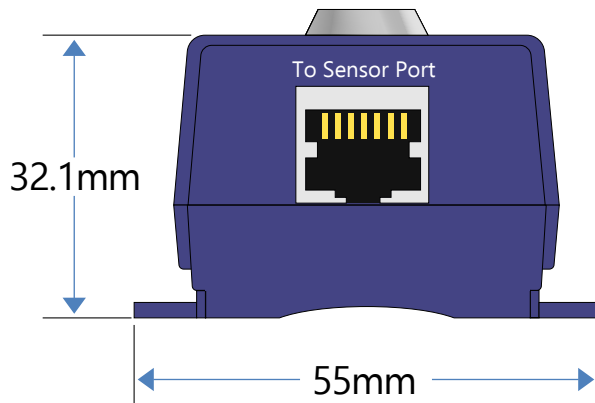
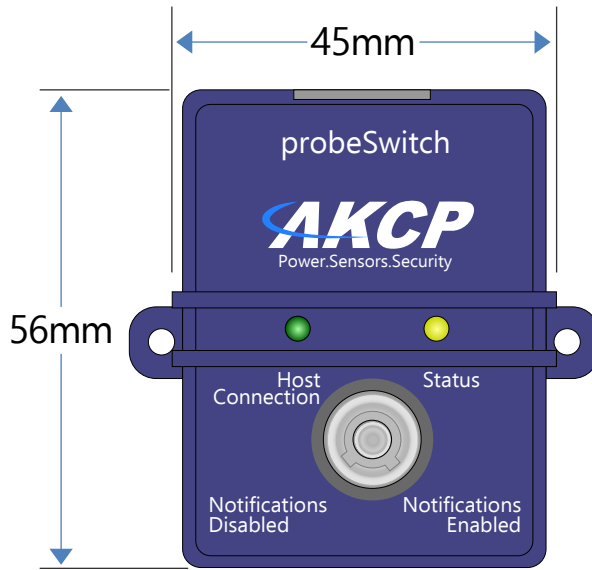

Modbus Adapter (MOD-A)



Convert the MOD/EXP port on sensorProbeX+ from CAT5 to 2 wire serial cable.

sensorProbeX+ comes equipped with an RS485 Modbus and Expansion port. When using this RJ45 port to connect Modbus appliances, the Modbus Adapter makes it easier to connect a 2 wire serial bus cable to the RJ45 port, converting the RJ45 connector into a 3 pin terminal block connection.

Technical Specifications

Connector	Connector 3 pin phoenix connector : A+, B+, GND
Electrical	Electrical no galvanic isolation
Components	Manufactured using highly integrated, low power surface mount technology to ensure long term reliability.
Operating Environment	Temperature : Min. -35° C – Max.80° C
Humidity:	Min. 20% – Max. 80% (Non-Condensing)
Interface	
Communications cable	RJ-45 jack to sensor using UTP CAT5e/6 cable
Power source	Powered by the controller unit. No additional power needed
Power Consumption	Typical 0 mWatt, 0 mA
Maximum Cable Length	The Modbus Adaptor can be extended from the RJ-45 Intelligent Sensor ports on the base units up to 1800 feet, or 550 meters using standard CAT5/6 LAN cable
Dimensions	56 x 55 x 33.3 mm
Mounting	DIN rail mounting
	Screw mounting

MOD-A - Technical Drawing

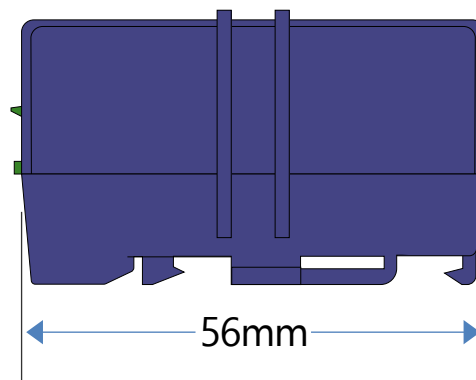
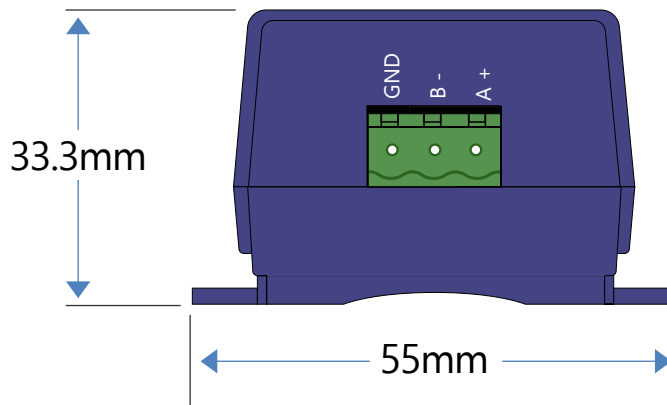
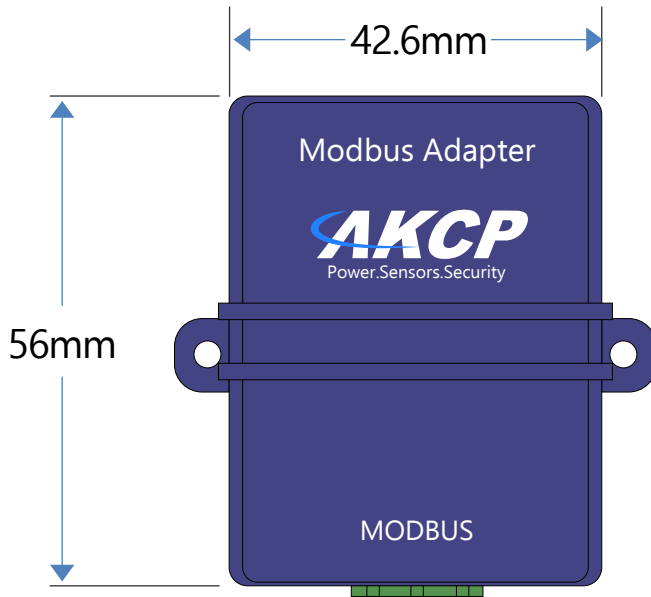

Sensor Adapter (SEN-A)



Third Party Sensor Adapter

**Connect sensors with 0-5 VDC output.
Connect Dry Contacts requiring 5VDC power**

The Sensor Adapter makes it easy to connect third party sensors that output a 0-10 DC Voltage scale.

A switch on the side of the sensor adapter allows you to switch to a dry contact I/O instead, which is capable of maintaining a 5VDC output to power the sensor at all times, while still monitoring the dry contact input.

SEN-A - Technical Specification

Measuring	Specifications
Configuration	Selectable type, with autosense setting : + 0~10 VDC + Dry Contact Input/Output
Connector	3 pin phoenix connector + Voltage Input : Signal, 5V, GND + Dry Contact : Dry Contact, 5V, GND
Electrical	no galvanic isolation can provide up to 5V 0.2A for 3rd party device powering
Interface	Interface
Communications cable	RJ-45 jack to sensor using UTP CAT5e/6 cable
Power source	Powered by the controller unit. No additional power needed
Power Consumption	Typical 50 mWatt, 10 mA
Maximum Cable Length	The Sensor Adaptor can be extended from the RJ-45 Intelligent Sensor ports on the base units up to 50 feet, or 15 meters using standard CAT5/6 LAN cable
Components	Manufactured using highly integrated, low power surface mount technology to ensure long term reliability.
Operating Environment	Temperature : Min. -35° C – Max.80° C Humidity: Min. 20% – Max. 80% (Non-Condensing)
Dimensions	56 x 55 x 33.3 mm
Mounting	DIN rail mounting Screw mounting
Sensor count	1

SEN-A - Technical Drawing

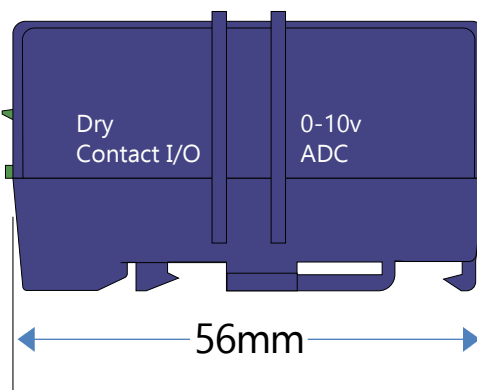
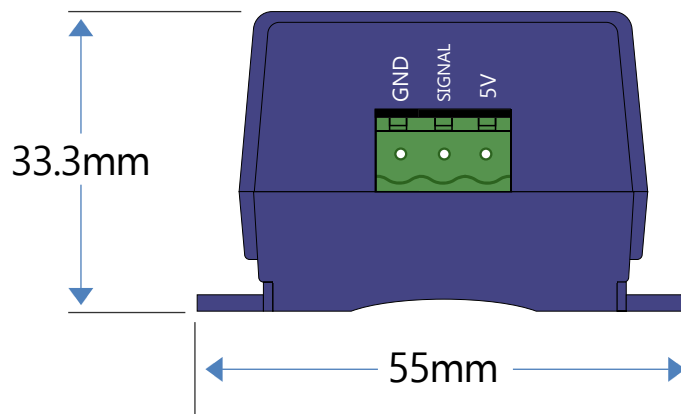
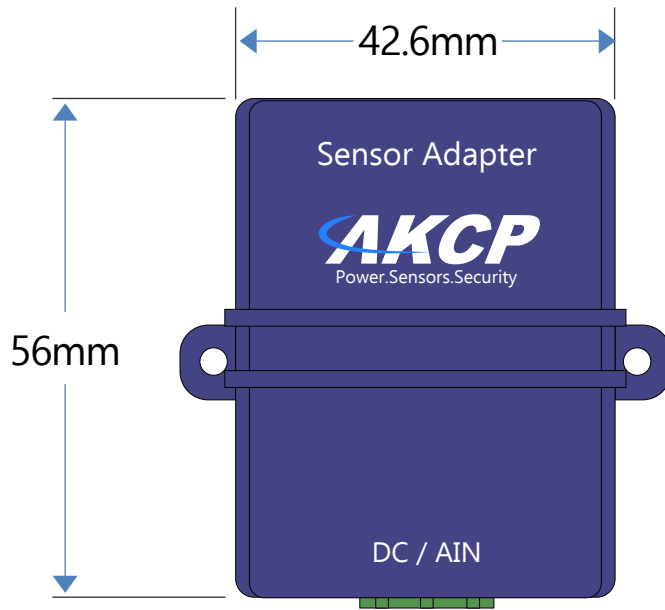

Rack & DIN Accessories



Rack Mount Kit

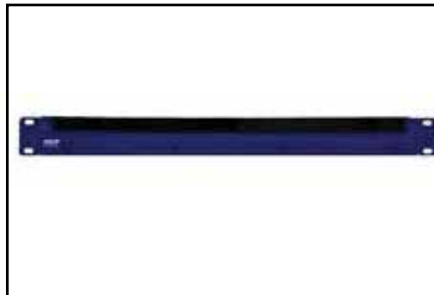

Rack Containment



LCD Mounting Bracket

Rack Mount Kits

AKCP Rack Mount kits are available in different configurations to help meet your requirements. There are three different configurations to ensure that all your permutations are covered. Whatever your cabinet space requirements are, AKCP has the appropriate answer. Get your server cabinets organized and utilize the space to maximize efficiency



Single 1U Din Rail Rack mount kit DN1U

- Ideal for mounting your sensors and sensorProbe2
- No more wasted space
- Compatible with all AKCP DIN rail mounted sensor boxes
- Includes 2x DIN rail clips



Split 1U Din Rail Rack mount kit DN1USP

- Ideal for fitting a sensorProbe plus sensors
- Ideal for fitting securityProbe with sensors
- 8.5" of space available for sensors
- Compatible with all AKCP DIN rail mounted sensor boxes



Double Rack mount kit DR1U

- Only takes up 1U
- Ideal for mounting the securityProbe plus an expansion unit
- Option to add the 1U Din Rail Rack above for sensors

Rack Containment (1UBP, 1UBPB, 2UBP, 2UBPB)



Servers, and other rack mounted equipment are typically designed to draw cool air in through the front panel vents and exhaust the warm air through the rear. Having any gaps between equipment or "empty U's" can actually hurt your cooling efficiency by allowing cold air to pass through to the rear of the cabinet. If you have hot/cold aisle containment in your data center then this is definitely something you want to avoid! Conversely you don't want any hot air to pass to the front of the cabinet and be drawn back into your IT equipment.

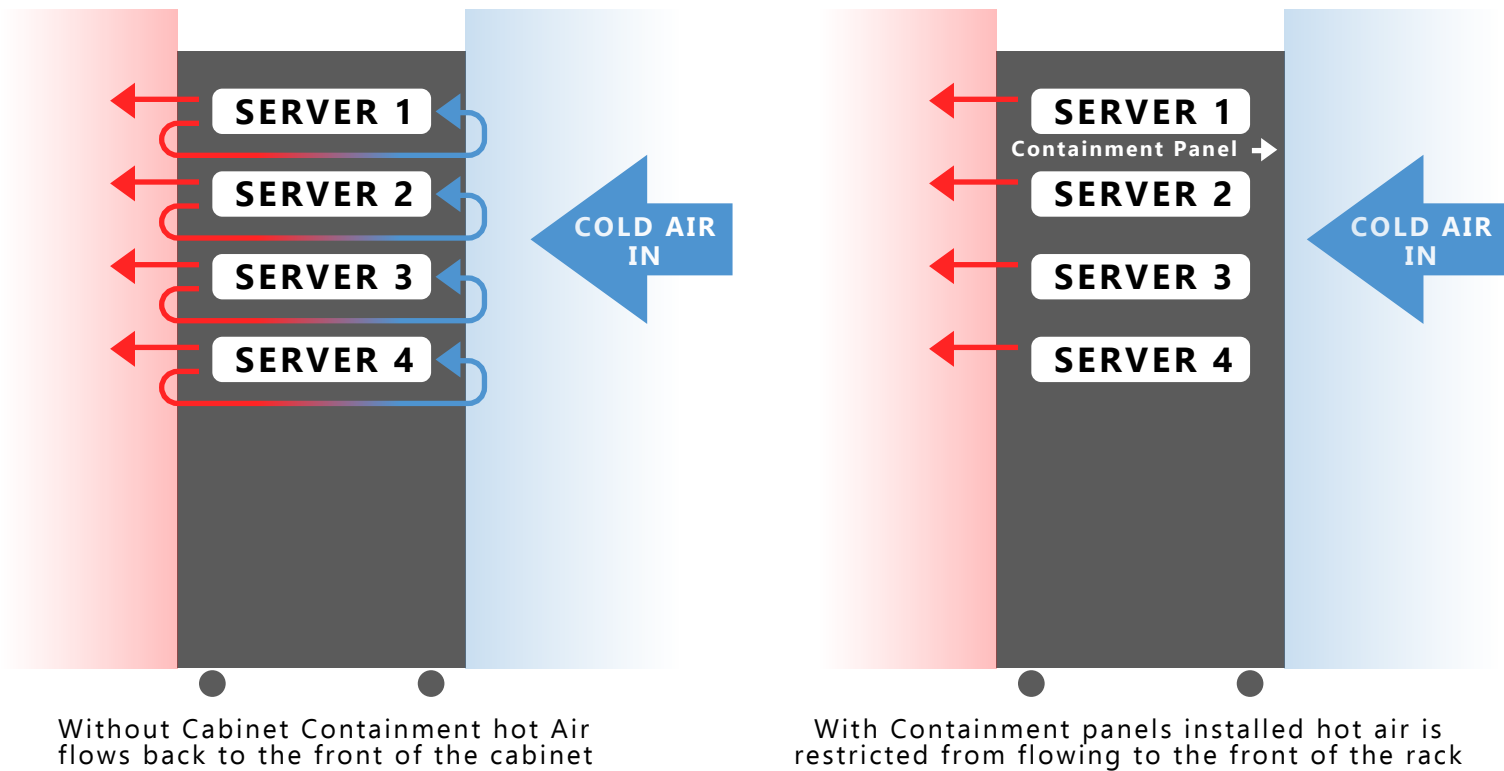

AKCP provide blanking panels that can be used to fill these 1U or 2U gaps you may have in your cabinet. They aid in sealing and containing the rack, preventing the hot/cold air mix that can so severely harm your PUE numbers.

Rack Containment - Technical Drawing

1U Blanking Panel With Cable Brushes

1UBPB

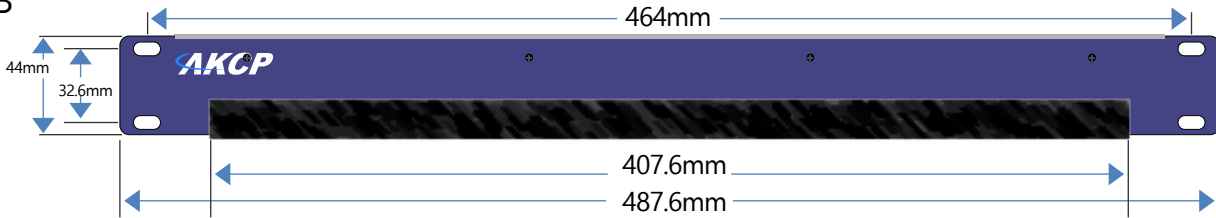

1U Blanking Panel

1UBP

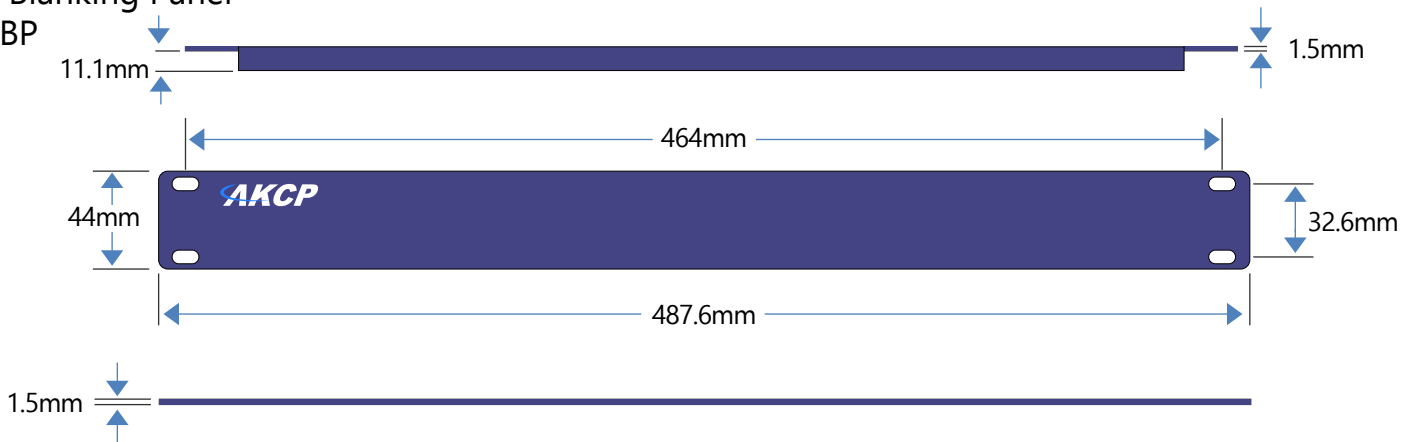

2U Blanking Panel With Cable Brushes

2UBPB

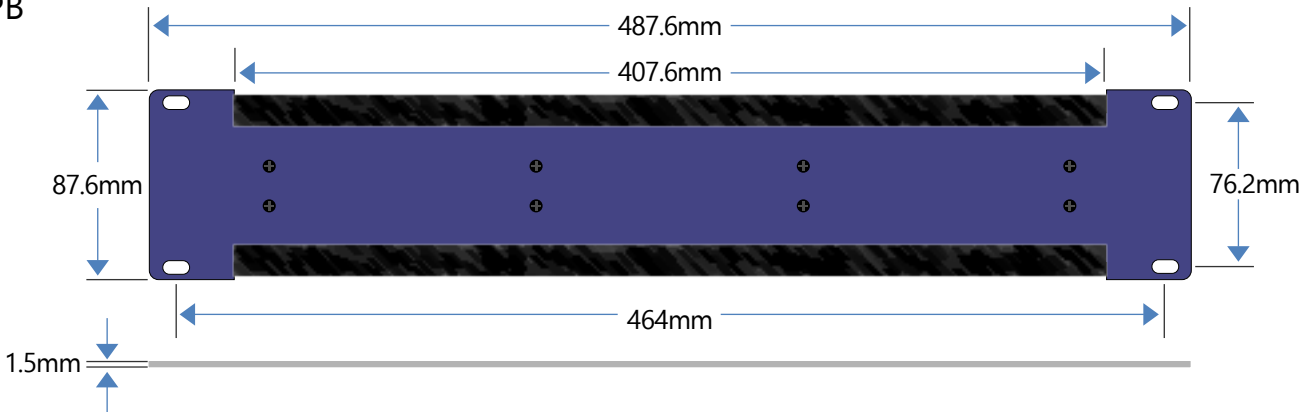

2U Blanking Panel

2UBP

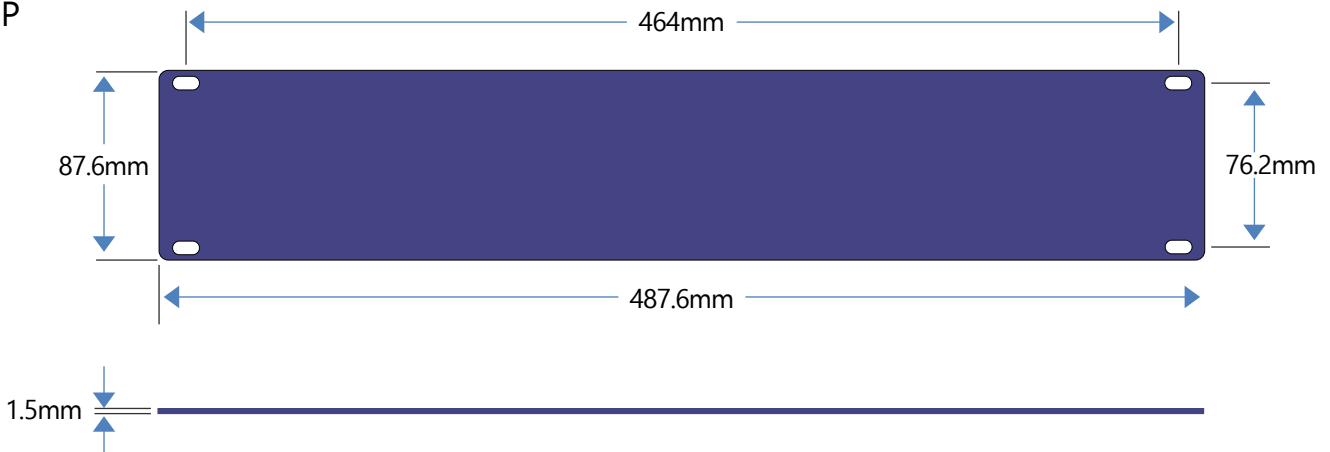

LCD Mounting Bracket

LCD 0U Bracket



LCD Bracket 45° Degrees



LCD Mounting Bracket - Technical Drawing

LCD 0U Bracket

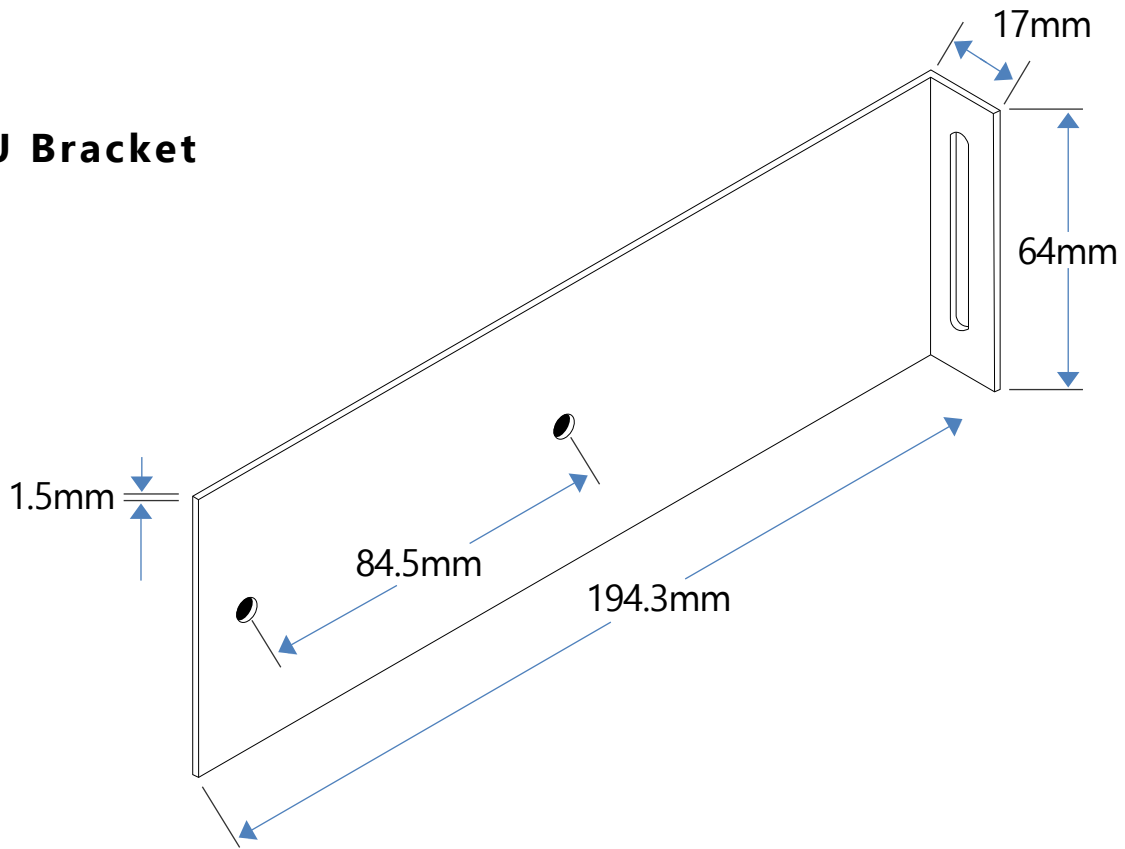

LCD Bracket 45° Degree

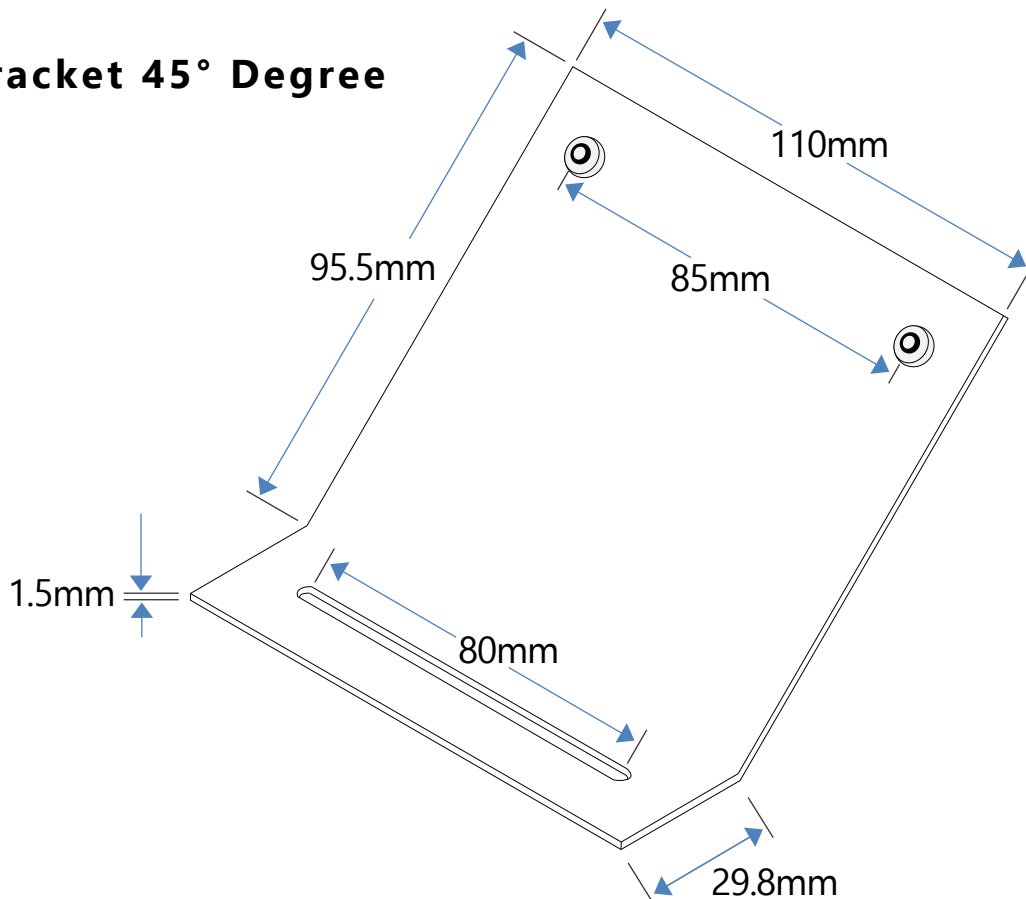

Power Supplies



DC-DC Converter
- DCW024-5



DC-DC Converter
- DCW048-5



DC-DC Converter
- DCW075



POE Splitter

DC-DC Power Converters

12-24 to 5VDC Converter (DCW024-5)



This DC to DC power converter can take in a range of voltage from 12-24 VDC. It is suitable for powering the SP2+, SPX+, SP2, SP4 and SP8 with its 5VDC 3Amp output.

48 to 5VDC Converter (DCW048-5)



Isolated 48 VDC power input, which converts to a 1.9Amp 5VDC output. Suitable for use with all 5VDC powered base units, such as the SP2, SP2+, SPX+, SP4, SP8.

40-60 to 7.5VDC Converter (DCW075)



40-60 VDC power input, which converts to a 7.5VDC output. Suitable for use with all 7.5VDC base units such as the SP8-X20, SP8-X60

POE Splitter (POE-EXT)



The POE Splitter is an external POE power supply for all 5VDC base units such as SP2+, SPX+, SP2, SP4 and SP8.

DCW024-5 - Technical Drawing

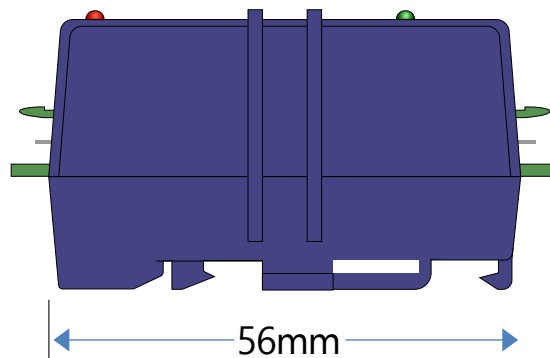
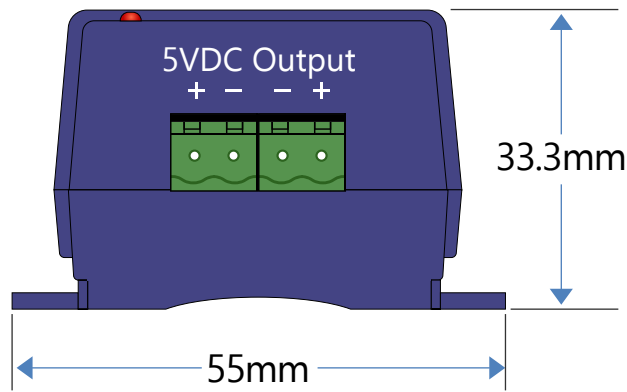
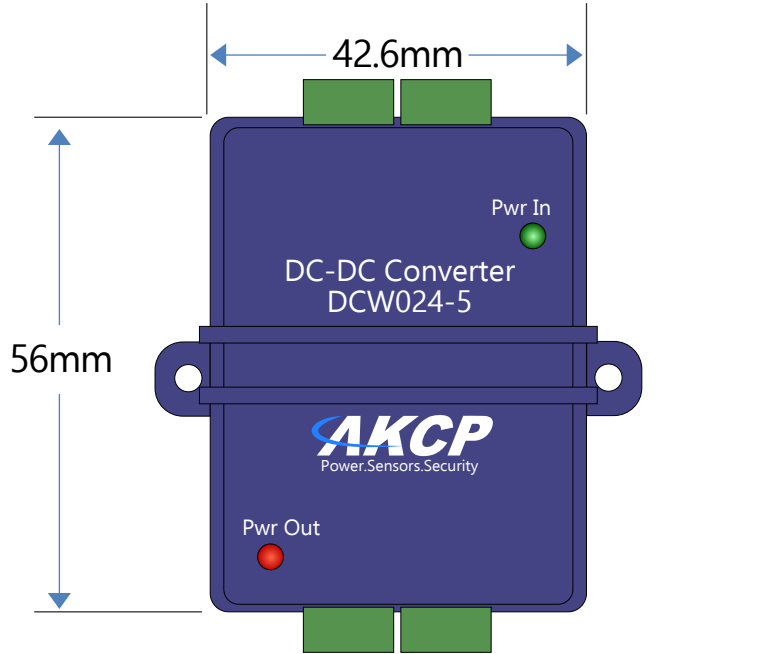

DCW048-5 - Technical Drawing

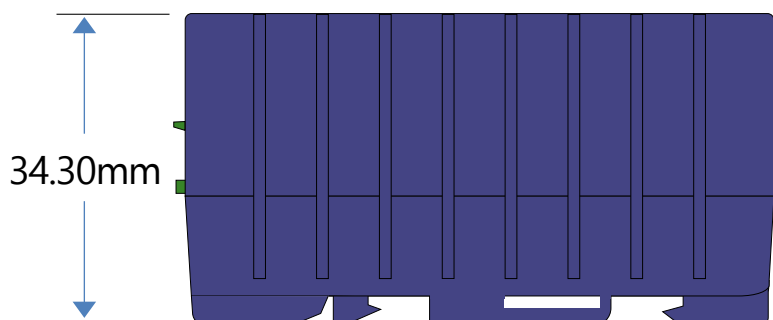
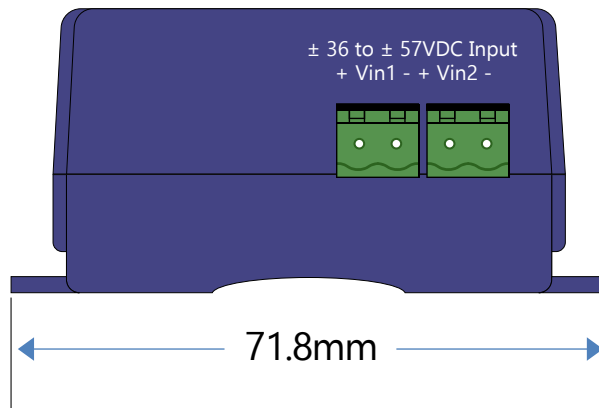
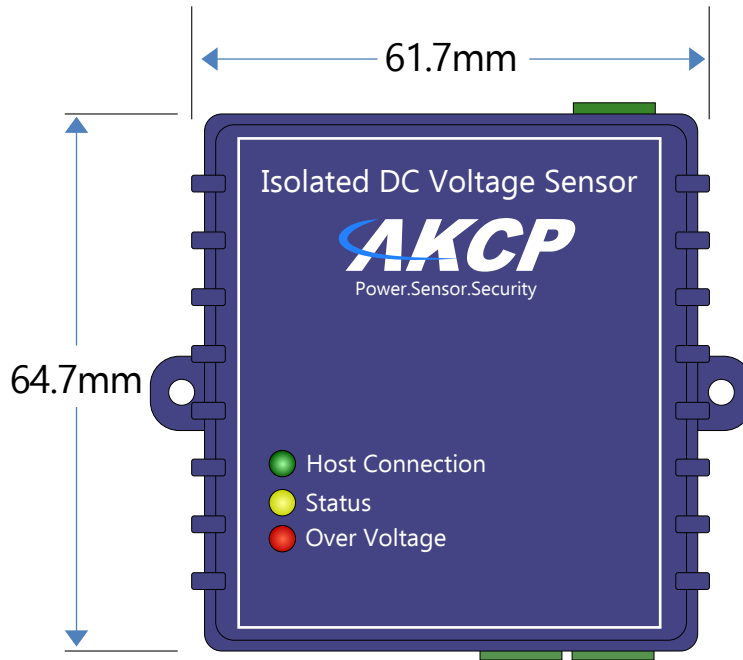

DCW075 - Technical Drawing

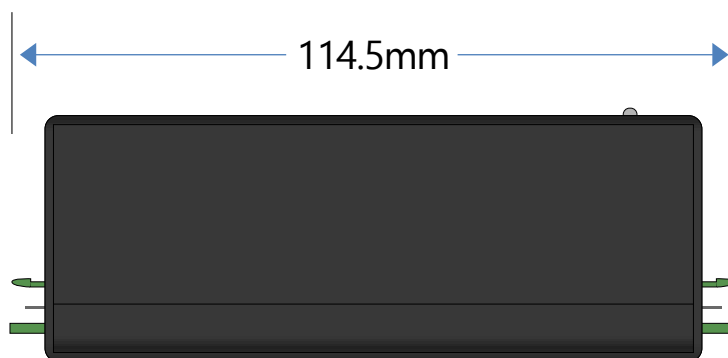
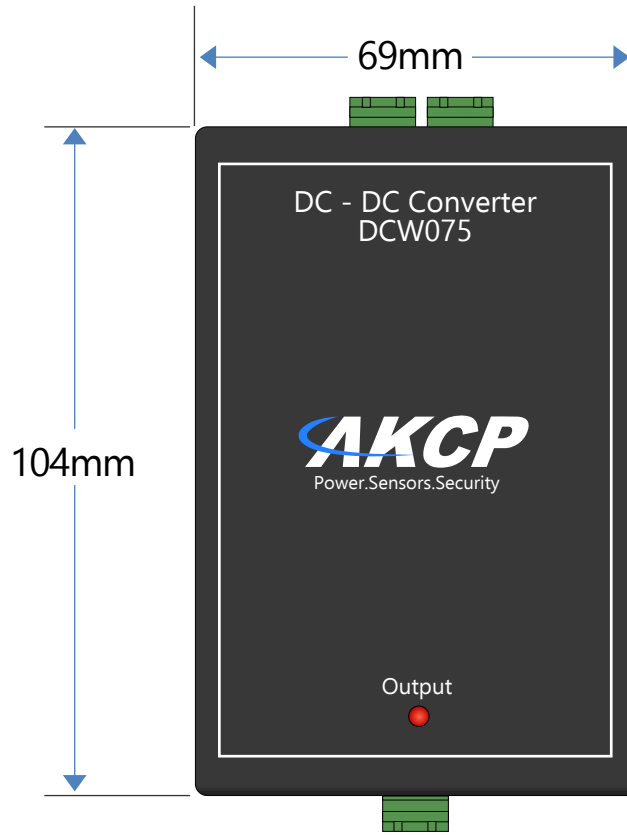

POE-EXT - Technical Drawing

